

Fan Cart

ME-6977

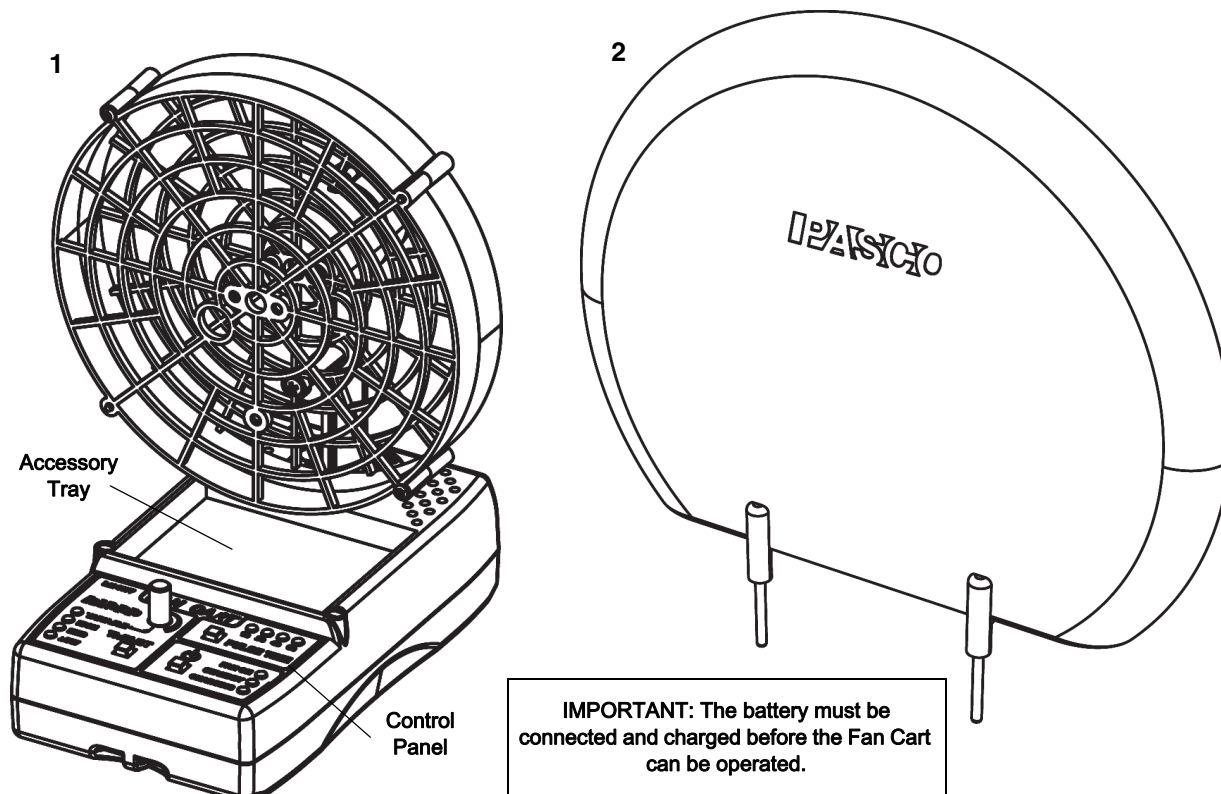

Included Equipment

- | | |
|--|---------|
| 1. Fan Cart | 2. Sail |
| 3. AC to 9 V DC power adapter plus plugs (not shown) | |

Compatible PASCO Tracks*

Part Number*

PAStack

ME-6960

1.2 m and 2.2 m PAScar Dynamics Tracks (no carts)

ME-6953 and ME-6954

(*See the PASCO Catalog or www.pasco.com for details)

Initial Step: Connect the Battery

Connecting the Battery - Tools Required: #0 or #1 Phillips screw driver. Remove the single screw on the bottom of the Fan Cart that holds the battery compartment door, and remove the battery door from the Fan Cart. Slide out the Lithium Polymer (Li-Poly) battery pack and reach in to connect the battery cable to the connector on the circuit board. Place the battery into the compartment. Replace the battery door and the screw.

Next Step: Charge the Fan Cart Battery

The red LED next to CHARGING blinks when the battery needs to be charged.

Connect the AC to 9 V DC power adapter to an appropriate outlet. Plug the power cord into the socket on the left side of the Fan Cart. **IMPORTANT!** Use only the power adapter that is supplied with the Fan Cart to charge the battery.

The red LED next to CHARGING shines continuously while the battery is charging. The battery typically charges in less than two hours. When the red LED stops shining, disconnect the AC power adapter.

The Fan Cart cannot be operated when the AC power adapter is connected.

Introduction

The PASCO Fan Cart produces Low, Medium, High or Variable Thrust either continuously or for selectable time intervals of 1, 2, 4, or 6 seconds.

The direction of thrust can be adjusted from zero to 180 degrees to demonstrate the vector nature of force.

The Fan Cart has a sophisticated rechargeable-battery powered electronic controller that provides a constant voltage to the fan motor so that the Fan Cart approaches constant fan speed operation that is not dependent on the battery terminal voltage. The Fan Cart includes a power adapter with interchangeable plugs.



The Fan Cart nests on top of the PASCO Dynamics Cart or PAScar to utilize the Dynamics Cart's or PAScar's plunger and bumpers. The Fan Cart is also compatible with the Compact Cart Mass (ME-6755).

The Fan Cart is compatible with all PASCO tracks (please see the PASCO catalog) or can be used on a smooth surface without a track.

The Fan Cart comes with a Sail for the "Fan Cart with Sail" demonstration.

The Fan Cart has a light-emitting diode (LED) that indicates when the battery is being charged. The LED flashes when the battery is low.

Battery

The Fan Cart's high energy density lithium-polymer battery can run the fan continuously at medium thrust for about 1.5 hours before the 'low-battery' LED begins to flash. Since the battery recharges quickly (typically in one hour), even short periods (10 - 20 minutes) with the charger plugged in will recharge the battery sufficiently to continue.

- Partial charging and recharging will not adversely affect the battery life.
- The replaceable battery pack is designed to last at least five years in normal application.
- Unlike nickel-cadmium batteries, for maximum battery life, the lithium-polymer battery pack should not be run down completely before recharging.
- The battery pack can be left in a partially charged state for long periods without damage.

- Maximum battery life can be attained by charging the battery after each use.
- The charger may be left connected indefinitely because it shuts off automatically after the battery reaches full charge.

Operation

The control section of the Fan Cart has eleven light-emitting diodes (LEDs), a VARIABLE THRUST knob, and three selector switches: THRUST, PULSE TIME, and FAN ON, STANDBY. The CHARGING LED flashes when the battery needs to be recharged and stays lit while the Fan Cart is charging.

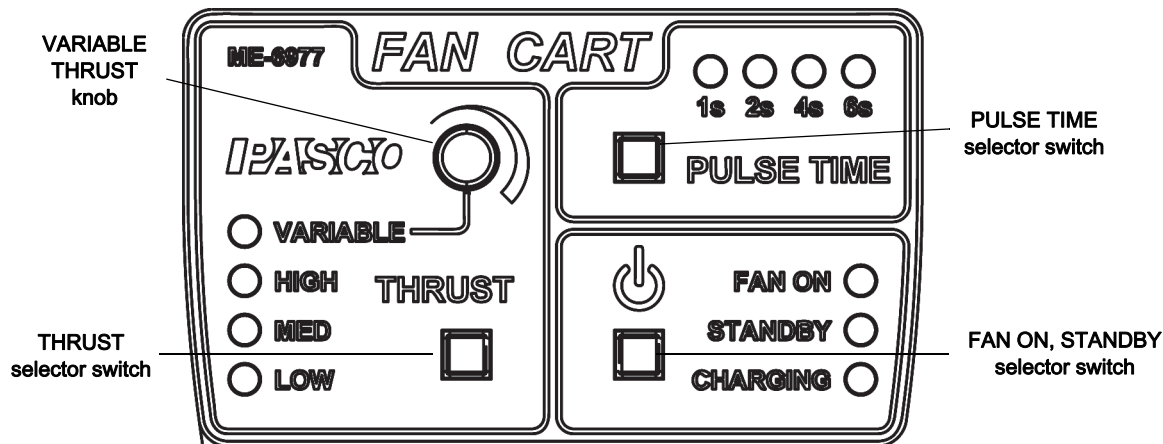

FAN ON, STANDBY, and OFF

To *turn on the Fan Cart*, press the FAN ON, STANDBY selector switch. The LEDs will light momentarily, and then the green LED next to STANDBY will remain lit.

To *turn on the fan*, press the FAN ON, STANDBY selector switch again. The fan will turn on and the yellow LED next to FAN ON will remain lit. The default setting is continuous blowing at LOW THRUST.

To *turn off the fan*, press the FAN ON, STANDBY selector switch again. The fan will turn off and the green LED next to STANDBY will remain lit.

To *turn off the Fan Cart*, press-and-hold the FAN ON, STANDBY selector switch for one or two seconds. The green LED next to STANDBY will stop shining.

THRUST Settings

To change the THRUST setting from the default value (LOW), press the THRUST selector switch once to select MEDIUM. Press the selector switch again to select HIGH, and press the selector switch again to select VARIABLE. Press the selector switch once again to return the THRUST setting to the default value.

When the THRUST setting is set to VARIABLE, turn the VARIABLE THRUST knob clockwise to increase the thrust or counterclockwise to decrease the thrust.

CAUTION!

Keep fingers and other objects away from the moving fan blade.

NOTE: The Fan Cart turns itself off if it is not used for ten minutes.

You can change the THRUST setting while the fan is in STANDBY, or while the fan is on.

PULSE TIME Settings

You can change PULSE TIME settings only while the fan is in STANDBY.

Press the PULSE TIME selector switch once to select 1 s (one second). Press the switch again to select 2 s (two seconds). Press the switch again to select 4 s (four seconds), and press the switch again to select 6 s (six seconds).

Press the PULSE TIME selector switch once again to return to the default setting (continuous blowing). No LEDs in the PULSE TIME section will be lit.

Once you have set the PULSE TIME setting, press the FAN ON, STANDBY selector switch. The green LED next to STANDBY will blink three times, and then the fan will turn on and run for the selected amount of time.

If you want a PULSE TIME to repeat itself, press-and-hold the PULSE TIME selector switch until the LED for the desired time interval begins to blink. Press the FAN ON, STANDBY selector switch. The green LED next to STANDBY will blink three times and the fan will turn on and run for the selected time interval and then turn off. After a total of twelve seconds from when the fan first turns on, it will turn on again and run for the selected time interval. For example, if 2 s is selected and you press-and-hold the PULSE TIME selector switch (and then press FAN ON, STANDBY), the fan will run for two seconds and then turn off for ten seconds before turning on again for two seconds.

NOTE: A summary of the operating instructions is on the battery compartment door on the bottom of the Fan Cart.

Charging the Fan Cart

The red LED next to CHARGING blinks when the battery needs to be charged.

Connect the AC to 9 V DC power adapter to an appropriate outlet. Plug the power cord into the socket on the left side of the Fan Cart. **IMPORTANT!** Use only the power adapter that is supplied with the Fan Cart to charge the battery.

The red LED next to CHARGING shines continuously while the battery is recharging. When the red LED stops shining, disconnect the AC power adapter.

The Fan Cart cannot be operated when the AC power adapter is connected.

NOTE: To cancel the PULSE TIME repeat function, press the PULSE TIME selector switch again.

NOTE! If you ignore the blinking red LED and the battery pack becomes severely discharged, the Fan Cart will turn itself off and the red LED will not shine. The Fan Cart will not operate when the battery becomes severely discharged.

Demonstrations and Experiments

Using the Fan Cart and Sail

1. Place the Fan Cart on a level track.
2. Set the fan angle to zero degrees. Set the THRUST to MEDIUM and set the PULSE TIME to 2 s (two seconds).

- Turn the fan on to demonstrate which way the Fan Cart moves without the sail.

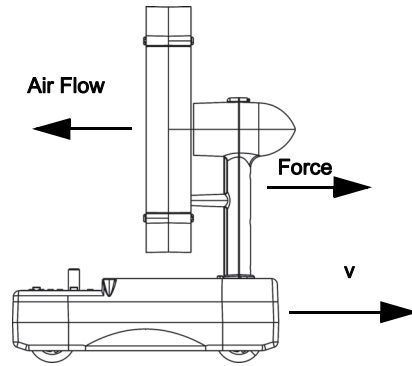

- Attach the Sail to the Fan Cart by plugging the pegs of the sail into the holes at the edge of the accessory tray on the cart. Attach the Sail so that its flat side faces the fan.

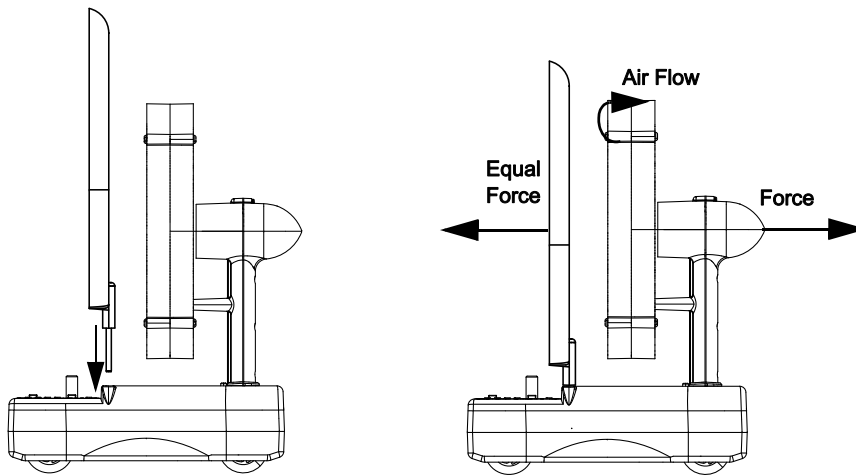

- Set the THRUST to VARIABLE, turn on the fan, and turn the VARIABLE THRUST knob fully clockwise. Then, adjust the VARIABLE THRUST knob so that the fan remains motionless. Turn the fan off after a short period of time.
- Leave the thrust at the same setting, but remove the Sail and re-attach it so that its curved side faces the fan.

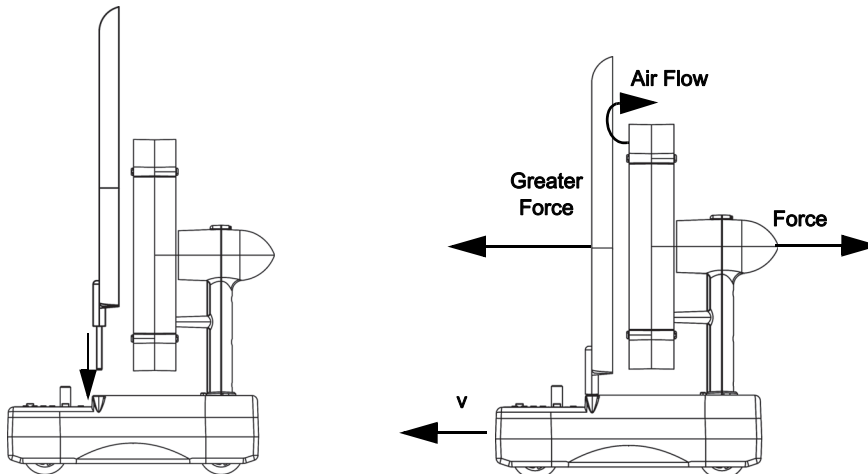

NOTE: Many students will expect the cart to not move. However, the cart will have a small acceleration opposite to the acceleration without the sail.

7. Ask the students to predict which direction the cart will move with the sail attached. Turn the fan on to show the direction of the cart's motion.

Explanation: There is a force on the cart in one direction due to the fan pushing air and there is another force on the cart in the opposite direction due to air hitting and bouncing off of the sail. The bouncing air hitting the *curved* side of the sail causes the force on the sail to be greater than the force of the air on the fan.

Suggested Experiments

Experiment #1:

Use a Motion Sensor or Tape Timer to measure the acceleration of the Fan Cart due to a constant force. Add mass to the accessory tray of the cart and repeat. Determine the relationship of acceleration to mass for a constant force.

Experiment #2:

Determine the force of the Fan Cart by connecting the cart to a mass that hangs over a pulley. Adjust the hanging mass until the cart doesn't move.

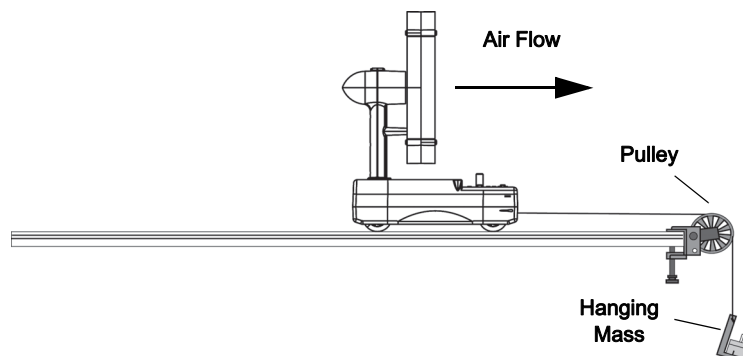

Next, turn the fan at an angle and determine the component of the force. Determine whether the force component in the direction of motion is $F \cos \theta$. (This experiment must be performed on a PASCO track so the cart will go in a straight line.)

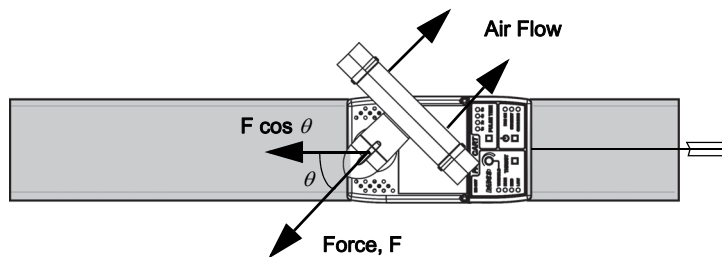

Experiment #3:

Put the Fan Cart on a track and incline the track until the cart can't climb the incline.

Experiment #4:

Put the Fan Cart on top of the PASCO Friction Cart and adjust the friction (or the VARIABLE THRUST on the Fan Cart) until the cart goes at a constant speed.

Experiment #5: The Cart Race

Set up a “race” between the Fan Cart and a Motorized Cart (PASCO Model ME-9781). Put two PASCO tracks side by side. Mount a Motion Sensor on the left end of each track. Place the carts on the tracks approximately 15 cm in front of the sensors. Position the carts so that they start at the same position. Set the Fan Cart’s thrust to LOW. Adjust the Motorized Cart’s speed to maximum. Start the carts going at the same time. Starting at the same point and time, the constant speed Motorized Cart initially takes the lead but is ‘caught’ and passed by the Fan Cart moving at a constant acceleration.

Specifications

Mass, Fan Cart, and Mass, Sail	Approximately 0.300 kg and approximately 0.100 kg
Battery Pack	7.2 volts, 1.25 amp-hour. One hour typical recharge time.
Thrust: LOW, MEDIUM, and HIGH	Approximately 0.04 N, 0.15 N, and 0.22 N
Thrust: VARIABLE (minimum to maximum)	Approximately 0.01 N to 0.23 N

Technical Support

For assistance with any PASCO product, contact PASCO at:

Address: PASCO scientific
10101 Foothills Blvd.
Roseville, CA 95747-7100

Phone: 916-462-8384 (worldwide)
800-772-8700 (U.S.)

Web: www.pasco.com

Email: support@pasco.com

Limited Warranty

For a description of the product warranty, see the PASCO catalog.

Copyright

The PASCO scientific 012-10538D *Fan Cart Instruction Manual* is copyrighted with all rights reserved. Permission is granted to non-profit educational institutions for reproduction of any part of this manual, providing the reproductions are used only in their laboratories and classrooms, and are not sold for profit. Reproduction under any other circumstances, without the written consent of PASCO scientific, is prohibited.

Trademarks

PASCO, PASCO scientific, PASPORT, and Xplorer GLX are trademarks or registered trademarks of PASCO scientific, in the United States and/or in other countries. For more information visit www.pasco.com/legal. Windows is a registered trademark of Microsoft Corporation in the United States and/or other countries. Mac is a trademark of Apple Computer, Inc., registered in the U.S. and other countries.

Product End of Life Disposal Instructions:

This electronic product is subject to disposal and recycling regulations that vary by country and region. It is your responsibility to recycle your electronic equipment per your local environmental laws and regulations to ensure that it will be recycled in a manner that protects human health and the environment. To find out where you can drop off your waste equipment for recycling, please contact your local waste recycle/disposal service, or the place where you purchased the product.



The European Union WEEE (Waste Electronic and Electrical Equipment) symbol above and on the product or its packaging indicates that this product **must not** be disposed of in a standard waste container.

Fan Cart Battery Replacement and Disposal Instructions:

Removal/Replacement - Tools Required: #0 or #1 Phillips screw driver.

Remove the single screw holding the battery door, and remove the battery door from the Fan Cart. Slide out the Lithium Polymer (Li-Poly) battery pack and reach in to disconnect the battery cable connector. Reverse these instructions for a battery replacement.

Battery Disposal: Batteries contain chemicals that, if released, may affect the environment and human health. Batteries should be collected separately for recycling, and recycled at a hazardous material disposal location adhering to your country and local government regulations. To find out where you can drop off your waste battery for recycling, please contact your local waste disposal service, or the place where you purchased the product.

The Li-Poly rechargeable battery used in this product is marked with the international symbols (to the right) to indicate the need for the separate collection and recycling of batteries.



Li-Poly

Summary of Operations

