

Includes
Teacher's Notes
and
Typical
Experiment Results



**Instruction Manual and
Experiment Guide for
the PASCO scientific
Model WA-9612**

012-03541F
3/95

RESONANCE TUBE

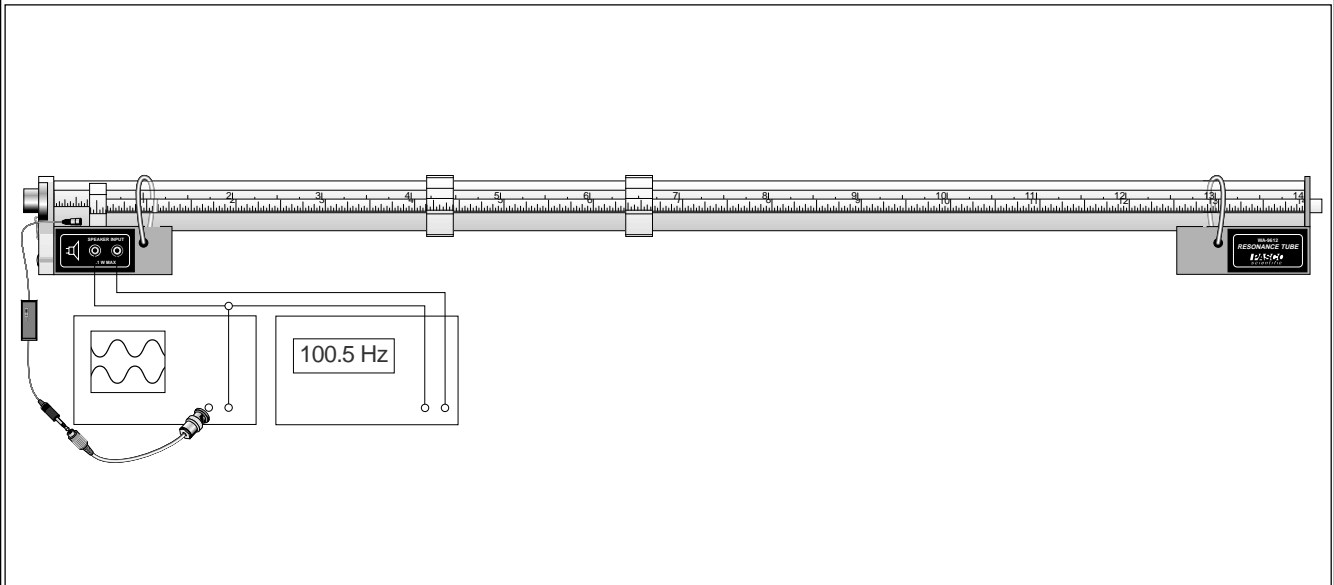

© 1988 PASCO scientific

\$7.50

Note: On several pages, the impedance of the small speaker is listed as 32 ohms. This is incorrect. The impedance of the small speaker is 8 ohms at 1500 hertz (Hz).

Table of Contents

Section	Page
Copyright, Warranty and Equipment Return	ii
Introduction	1
Equipment and Setup	1
Using the Resonance Tube:	
with the PASCO Series 6500 Computer Interface	3
with the Power Amplifier:	3
with the Data Monitor Program:	3
Waves in a Tube Theory:	4
Experiments:	
Experiment 1: Resonant Frequencies of a Tube	7
Experiment 2: Standing Waves in a Tube	9
Experiment 3: Tube Length and Resonant Modes	13
Experiment 4: The Speed of Sound in a Tube	15
Suggested Demonstration	17
Suggested Research Topics	18
Teacher's Guide	19
Technical Support	Inside Back Cover

Copyright, Warranty and Equipment Return

Please—Feel free to duplicate this manual subject to the copyright restrictions below.

Copyright Notice

The PASCO scientific Model WA-9612 Resonance Tube manual is copyrighted and all rights reserved. However, permission is granted to non-profit educational institutions for reproduction of any part of this manual providing the reproductions are used only for their laboratories and are not sold for profit. Reproduction under any other circumstances, without the written consent of PASCO scientific, is prohibited.

Limited Warranty

PASCO scientific warrants this product to be free from defects in materials and workmanship for a period of one year from the date of shipment to the customer. PASCO will repair or replace, at its option, any part of the product which is deemed to be defective in material or workmanship. This warranty does not cover damage to the product caused by abuse or improper use. Determination of whether a product failure is the result of a manufacturing defect or improper use by the customer shall be made solely by PASCO scientific. Responsibility for the return of equipment for warranty repair belongs to the customer. Equipment must be properly packed to prevent damage and shipped postage or freight prepaid. (Damage caused by improper packing of the equipment for return shipment will not be covered by the warranty.) Shipping costs for returning the equipment, after repair, will be paid by PASCO scientific.

Credits

This manual authored by: Clarence Bakken

This manual edited by: Eric Ayars

Teacher's guide written by: Eric Ayars

Equipment Return

Should the product have to be returned to PASCO scientific for any reason, notify PASCO scientific by letter, phone, or fax BEFORE returning the product. Upon notification, the return authorization and shipping instructions will be promptly issued.

► **NOTE:** NO EQUIPMENT WILL BE ACCEPTED FOR RETURN WITHOUT AN AUTHORIZATION FROM PASCO.

When returning equipment for repair, the units must be packed properly. Carriers will not accept responsibility for damage caused by improper packing. To be certain the unit will not be damaged in shipment, observe the following rules:

- ① The packing carton must be strong enough for the item shipped.
- ② Make certain there are at least two inches of packing material between any point on the apparatus and the inside walls of the carton.
- ③ Make certain that the packing material cannot shift in the box or become compressed, allowing the instrument come in contact with the packing carton.

Address: PASCO scientific
10101 Foothills Blvd.
Roseville, CA 95747-7100

Phone: (916) 786-3800
FAX: (916) 786-3292
email: techsupp@pasco.com
web: www.pasco.com

Introduction

The PASCO Model WA-9612 Resonance Tube lets you investigate the propagation of sound waves in a tube. You can observe standing wave patterns in a closed or open tube, and locate nodes and antinodes while varying the length of the tube. You can measure the speed of sound in the tube either indirectly, by measuring the frequency and wavelength of a resonance mode, or more directly, by using a triggered oscilloscope to measure the transit times for sound pulses along the tube. The tube also has two holes in it that can be covered or uncovered to investigate the physics of wind instruments.

Waves in the tube are produced by a speaker and detected by a miniature microphone. The microphone can be mounted beside the speaker to detect resonance modes, or it can be mounted on a rod and moved through the tube to examine wave characteristics inside the tube.

► **NOTE:** To use the Resonance Tube, you will need an oscilloscope to examine the signal detected by the microphone, and a signal generator capable of driving the $5\ \Omega$ 0.1 W speaker.

Equipment and Setup

The WA-9612 Resonance Tube comes with the following equipment (see Figure 1):

- 90 cm clear plastic tube with a built-in metric scale
- Two tube mounting stands, one with a built-in speaker and a mount for the microphone
- Miniature microphone with a battery powered amplifier (battery included) and a coax connector for direct attachment to an oscilloscope

- Moveable piston
- Microphone probe rod (86 cm brass rod, not shown)
- Clamp-on hole covers

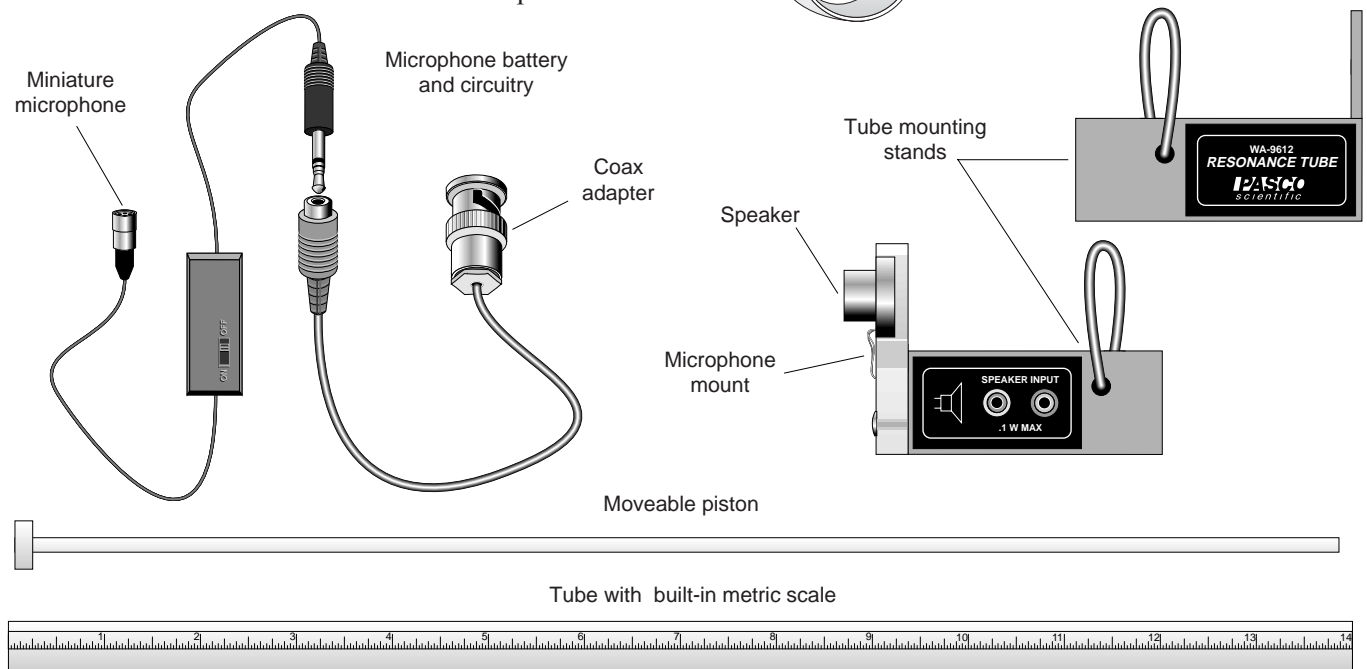

Figure 1 Equipment Included with the WA-9612 Resonance Tube

You will also need:

- A function generator capable of driving the $32\ \Omega$, 0.1 W speaker (such as the PASCO PI-9587B Digital Function Generator).
- An oscilloscope (such as the PASCO SB-9591)
- Banana plug hook-up wires for connecting your function generator to the speaker

To set up the Resonance Tube (see Figure 2):

- ① Set up the equipment as shown in Figure 2. The microphone can be mounted in the microphone hole below the speaker, or, as shown in the lower insert, it can be taped to the end of the microphone probe rod and inserted through the mounting hole so that nodes and antinodes can be located within the tube. You can also vary the effective tube length by inserting the moveable piston as shown in the upper insert. The end of the piston rod that is outside the tube should be supported to avoid putting excessive strain on the piston.
- ② Set the frequency of the function generator to approximately 100 Hz, and the amplitude to zero, then turn it on. Slowly raise the amplitude until you hear a sound from the speaker.

► **CAUTION:** You can damage the speaker by overdriving it. Raise the amplitude cautiously. The sound from the speaker should be clearly audible, but not loud. Note also that many function generators become more efficient at higher frequencies, so you may need to reduce the amplitude as you raise the frequency.

- ③ Turn on the oscilloscope and switch on the battery powered amplifier. Set the sweep speed to approximately match the frequency of the signal generator and set the gain until you can clearly see the signal from the microphone. If you can't see the microphone signal, even at maximum gain, adjust the frequency of the signal generator until the sound from the speaker is a maximum. Then raise the amplitude of the signal generator until you can see the signal clearly on the oscilloscope.
- ④ You can now find resonant modes by adjusting the frequency of the sound waves or the length of the tube, and listening for a maximum sound and/or watching for a maximum signal on the oscilloscope.

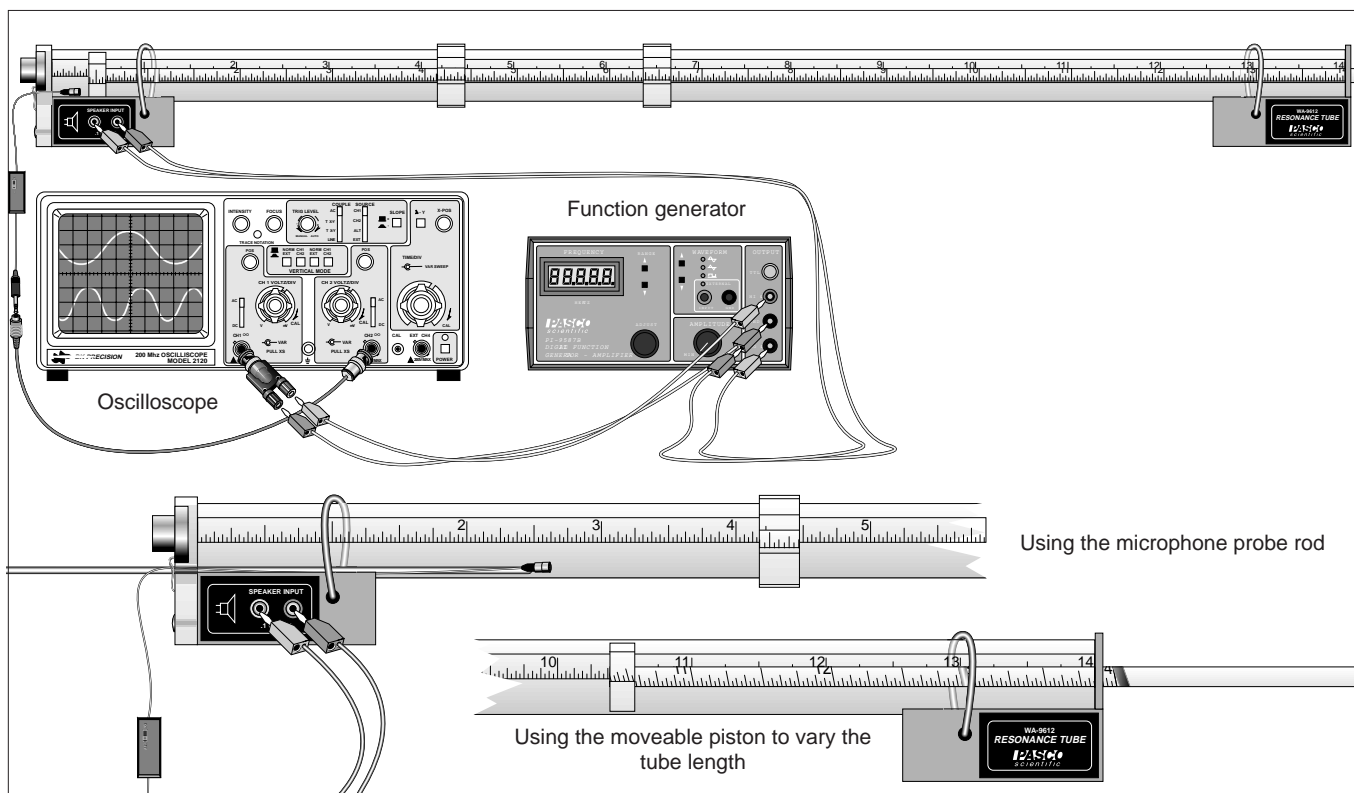

Figure 2 Equipment Setup

► **NOTE:** In most textbooks, an open tube is considered to be a tube that is open at both ends. A closed tube is considered to be a tube that is closed at one end and open at the other. In keeping with this convention, the speaker and microphone should be positioned several centimeters back from the end of the tube, so the microphone/speaker end of the tube is open.

If a resonance mode is excited in the tube, a pressure antinode (a displacement node) will always exist at a closed end of the tube. An open end of the tube corresponds, more or less, to a pressure node (a

Using the Power Amplifier:

Connect the Power Amplifier DIN plug to channel C of the Interface. Connect the output of the Power Amplifier to the resonance tube speaker, but **DO NOT TURN THE POWER AMPLIFIER ON UNTIL YOU HAVE SET THE OUTPUT AMPLITUDE FROM WITHIN THE PROGRAM.**

Connect the BNC plug on the resonance tube microphone to the BNC jack on the CI-6508 Input Adapter Box, and the DIN plug on the Adapter Box to channel A of the Interface. Turn the amplification select switch on the CI-6508 to 100x. (See Figure 3.)

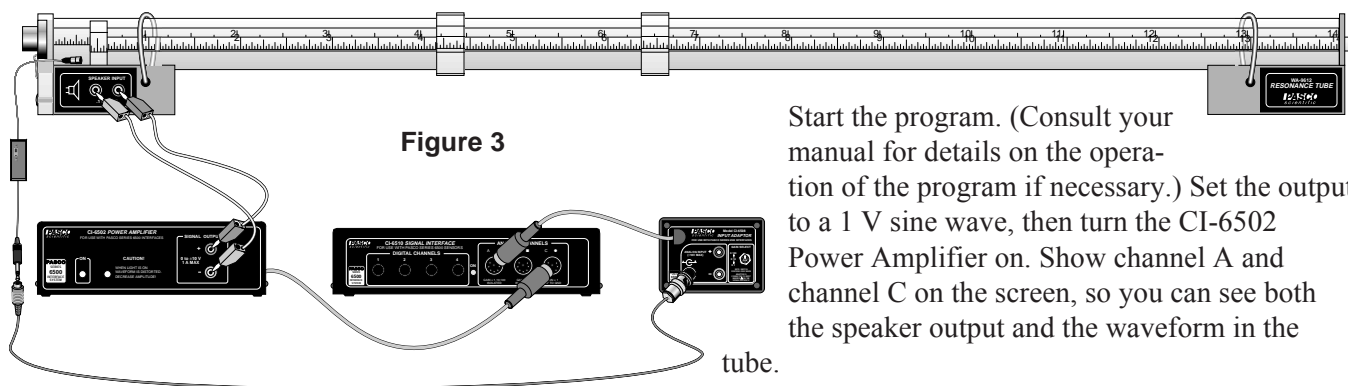

Figure 3

Start the program. (Consult your manual for details on the operation of the program if necessary.) Set the output to a 1 V sine wave, then turn the CI-6502 Power Amplifier on. Show channel A and channel C on the screen, so you can see both the speaker output and the waveform in the tube.

displacement antinode). However, the pressure node will, in general, not be located exactly at the end of the tube. You can investigate the behavior of the sound waves near the open end using the microphone.

Using the Resonance Tube with the PASCO Series 6500 Computer Interface

There are two ways of using the PASCO Series-6500 Computer Interface with the resonance tube, depending on whether you intend to drive the resonance tube with the CI-6502 Power Amplifier or with a separate function generator.

Using a Function Generator:

Connect the BNC plug on the Resonance tube microphone to the BNC jack on the CI-6508 Input Adapter Box, and the DIN plug on the Adapter Box to channel A of the Series-6500. Turn the amplification select switch on the CI-6508 to 100x.

If you have a CI-6503 Voltage Sensor, use it to link the function generator and channel B of the CI-6500. (This step is optional; it allows you to use the function generator for triggering, with slightly improved results.) See Figure 4.

Start the program. (Consult your manual for details on the operation of this program if necessary.) In oscillo-

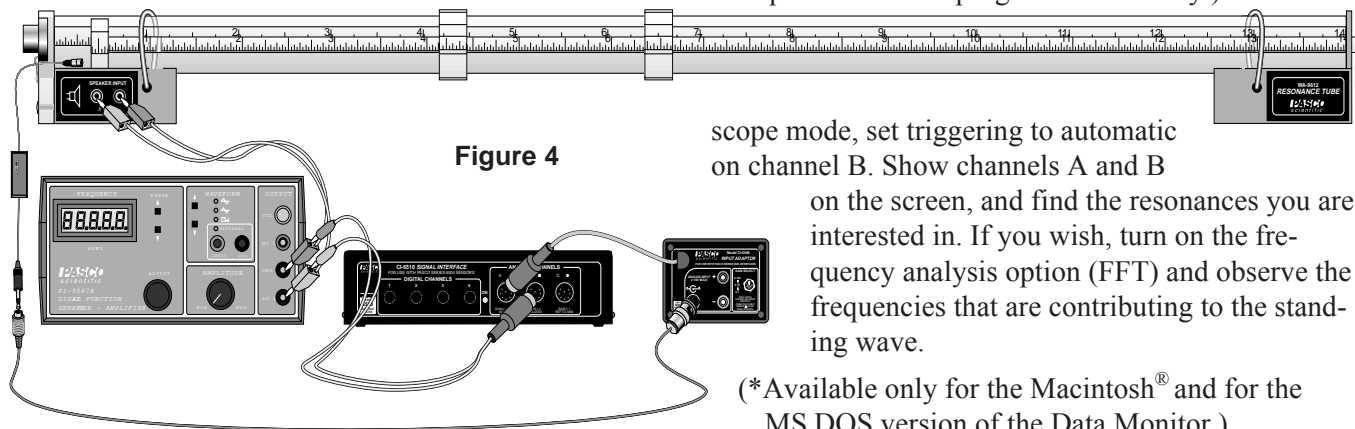

Figure 4

scope mode, set triggering to automatic on channel B. Show channels A and B on the screen, and find the resonances you are interested in. If you wish, turn on the frequency analysis option (FFT) and observe the frequencies that are contributing to the standing wave.

(*Available only for the Macintosh® and for the MS-DOS version of the Data Monitor.)

Waves in a Tube Theory:

Sound Waves

When the diaphragm of a speaker vibrates, a sound wave is produced that propagates through the air. The sound wave consists of small motions of the air molecules toward and away from the speaker. If you were able to look at a small volume of air near the speaker, you would find that the volume of air does not move far, but rather it vibrates toward and away from the speaker at the frequency of the speaker vibrations. This motion is very much analogous to waves propagating on a string. An important difference is that, if you watch a small portion of the string, its vibrational motion is transverse to the direction of propagation of the wave on the string. The motion of a small volume of air in a sound wave is parallel to the direction of propagation of the wave. Because of this, the sound wave is called a *longitudinal wave*.

Another way of conceptualizing a sound wave is as a series of compressions and rarefactions. When the diaphragm of a speaker moves outward, the air near the diaphragm is compressed, creating a small volume of relatively high air pressure, a compression. This small high pressure volume of air compresses the air adjacent to it, which in turn compresses the air adjacent to it, so the high pressure propagates away from the speaker. When the diaphragm of the speaker moves inward, a low pressure volume of air, a rarefaction, is created near the diaphragm. This rarefaction also propagates away from the speaker.

In general, a sound wave propagates out in all directions from the source of the wave. However, the study of sound waves can be simplified by restricting the motion of propagation to one dimension, as is done with the Resonance Tube.

Standing Waves in a Tube

Standing waves are created in a vibrating string when a wave is reflected from an end of the string so that the returning wave interferes with the original wave. Standing waves also occur when a sound wave is reflected from the end of a tube.

A standing wave on a string has nodes—points where the string does not move—and antinodes—points where the string vibrates up and down with a maximum amplitude. Analogously, a standing sound wave has displacement nodes—points where the air does not vibrate—and displacement antinodes—points where

the amplitude of the air vibration is a maximum. Pressure nodes and antinodes also exist within the waveform. In fact, pressure nodes occur at displacement antinodes and pressure antinodes occur at displacement nodes. This can be understood by thinking of a pressure antinode as being located between two displacement antinodes that vibrate 180° out of phase with each other. When the air of the two displacement antinodes are moving toward each other, the pressure of the pressure antinode is a maximum. When they are moving apart, the pressure goes to a minimum.

Reflection of the sound wave occurs at both open and closed tube ends. If the end of the tube is closed, the air has nowhere to go, so a displacement node (a pressure antinode) must exist at a closed end. If the end of the tube is open, the pressure stays very nearly at room pressure, so a pressure node (a displacement antinode) exists at an open end of the tube.

Resonance

As described above, a standing wave occurs when a wave is reflected from the end of the tube and the return wave interferes with the original wave. However, the sound wave will actually be reflected many times back and forth between the ends of the tube, and all these multiple reflections will interfere together. In general, the multiply reflected waves will not all be in phase, and the amplitude of the wave pattern will be small. However, at certain frequencies of oscillation, all the reflected waves are in phase, resulting in a very high amplitude standing wave. These frequencies are called *resonant* frequencies.

In Experiment 1, the relationship between the length of the tube and the frequencies at which resonance occurs is investigated. It is shown that the conditions for resonance are more easily understood in terms of the wavelength of the wave pattern, rather than in terms of the frequency. The resonance states also depend on whether the ends of the tube are open or closed. For an open tube (a tube open at both ends), resonance occurs when the wavelength of the wave (λ) satisfies the condition:

$$L = n\lambda/2, \quad n = 1, 2, 3, 4, \dots$$

where L = tube length.

These wavelengths allow a standing wave pattern such that a pressure node (displacement antinode) of the

wave pattern exists naturally at each end of the tube. Another way to characterize the resonance states is to say that an integral number of half wavelengths fits between the ends of the tube.

For a closed tube (by convention, a closed tube is open at one end and closed at the other), resonance occurs when the wavelength of the wave (λ) satisfies the condition:

$$L = n\lambda/4, \quad n = 1, 3, 5, 7, 9, \dots$$

These wavelengths allow a standing wave pattern such that a pressure node (displacement antinode)

occurs naturally at the open end of the tube and a pressure antinode (displacement node) occurs naturally at the closed end of the tube. As for the open tube, each successive value of n describes a state in which one more half wavelength fits between the ends of the tube.

► **NOTE:** The first four resonance states for open and closed tubes are diagramed below. The first resonance state ($n = 1$) is called the fundamental. Successive resonance states are called overtones. The representation in each case is relative displacement.

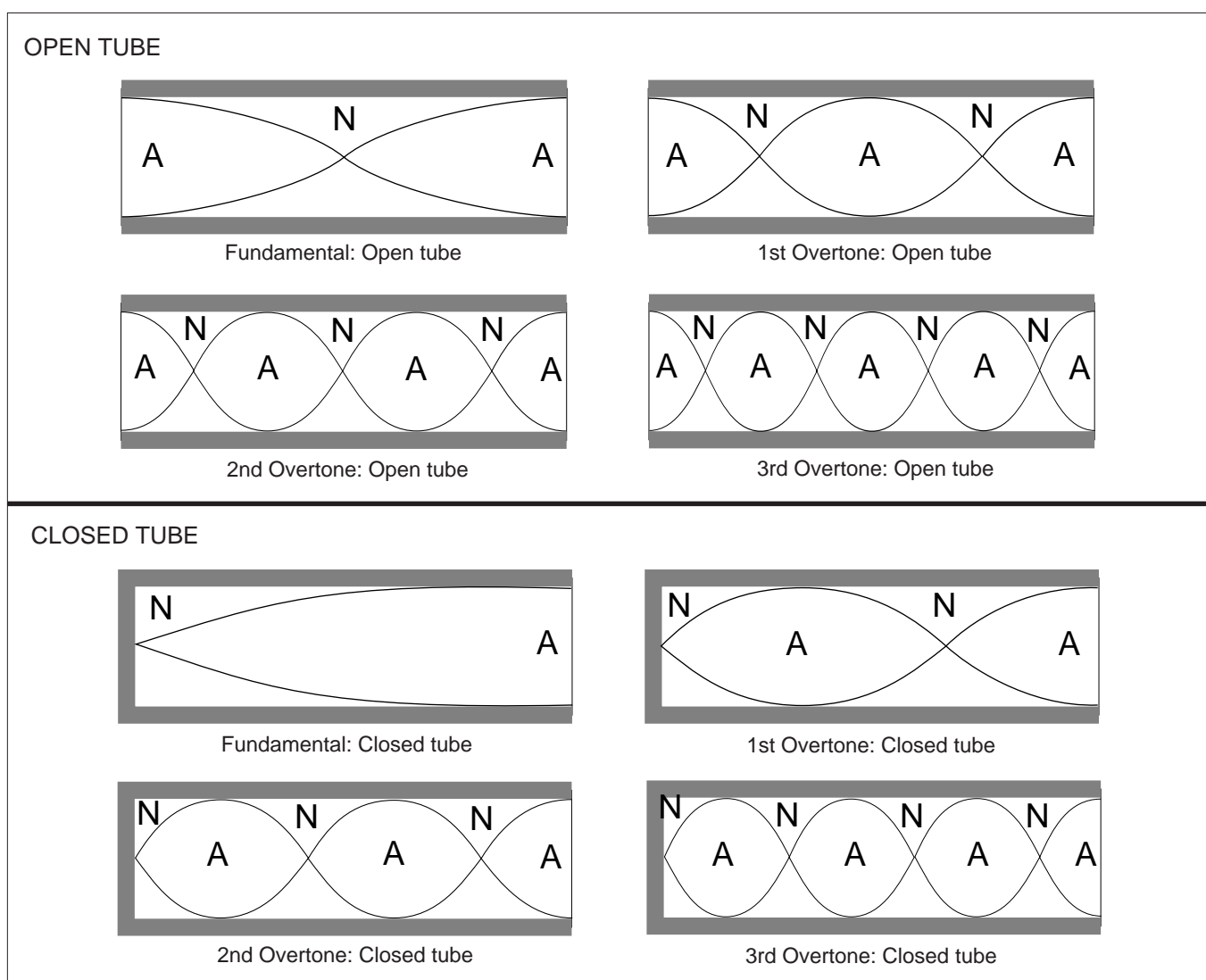

Resonance States: Open and Closed Tubes

The formulas and diagrams shown above for resonance in a tube are only approximate, mainly because the behavior of the waves at the ends of the tube (especially at an open end) depends partially on factors such as the diameter of the tube and the frequency of the waves. The ends of the tubes are not exact nodes and antinodes. It can be a useful experiment to investigate the wave behavior at the ends of the tube using the microphone. The following empirical formulas give a somewhat more accurate description of the resonance requirements for standing waves in a tube.

For an open tube:

$$L + 0.8d = n\lambda/2, \quad n = 1, 2, 3, 4, \dots$$

where L is the length of the tube and d is the diameter.

For a closed tube:

$$L + 0.4d = n\lambda/4, \quad n = 1, 3, 5, 7, 9, \dots$$

where L is the length of the tube and d is the diameter.

► **NOTE:** When using the microphone to investigate the waveform within the tube, be aware that the microphone is a pressure transducer. A maximum signal, therefore, indicates a pressure antinode (a displacement node) and a minimum signal indicates a pressure node (displacement antinode).

► **NOTE:** The following four experiments require the WA-9612 Resonance Tube, and a function generator capable of driving the 5Ω , 0.1 W speaker (such as the PASCO PI-9587C Digital Function Generator). You will also need banana plug hook-up wires to connect the function generator to the speaker. An oscilloscope (such as the PASCO SB-9591 Student Oscilloscope) is recommended for all the experiments and required for Experiment 4. If you are using a function generator that does not provide an accurate indication of frequency output, you will need a frequency counter (such as the SB-9599A Universal Digital Meter) for all four experiments.

Experiment 1: Resonant Frequencies of a Tube

EQUIPMENT NEEDED:

- PASCO Resonance Tube
- Function Generator
- Frequency Counter (if your function generator doesn't accurately indicate frequency)
- Oscilloscope (recommended, not necessary)

Introduction

When a speaker vibrates near a tube, there are certain frequencies at which the tube will amplify the sound from the speaker. These frequencies are called resonant frequencies, and occur because the dimensions of the tube are such that, at these frequencies, there occurs a maximum transfer of energy between the speaker and the tube.

Procedure

- ① Set up the Resonance Tube, oscilloscope, and function generator as shown in Figure 1.1. Turn on the oscilloscope. Set the oscilloscope sweep speed to approximately 5 ms/div and the gain on channel one to approximately 5 mV/div. Turn on the amplifier and the function generator. Set the output frequency of the function generator to approximately 100 Hz. Adjust the amplitude of the function generator until you can distinctly hear the sound from the speaker. If you use the oscilloscope, trigger on the speaker output.

► **WARNING:** You can damage the speaker by overdriving it. The sound from the speaker should be clearly audible, but not loud. Note also that many signal generators become more efficient and thus produce a larger output as the frequency increases, so you may need to reduce the amplitude as you increase the frequency.

- ② Increase the frequency slowly and listen carefully. In general, the sound will become louder as you increase the frequency because the function generator and speaker are more efficient at higher frequencies. However, listen for a relative maximum in the sound level—a frequency where there is a slight decrease in the sound level as you increase the frequency slightly. This relative maximum indicates a resonance mode in the tube. Adjust the frequency carefully to find the lowest frequency at which a relative maximum occurs. (You can also find the relative maximum by watching the trace on the oscilloscope. When the signal is a maximum height, you have reached a resonant frequency.) Record the value of this lowest resonant frequency as n_0 in Table 1.1

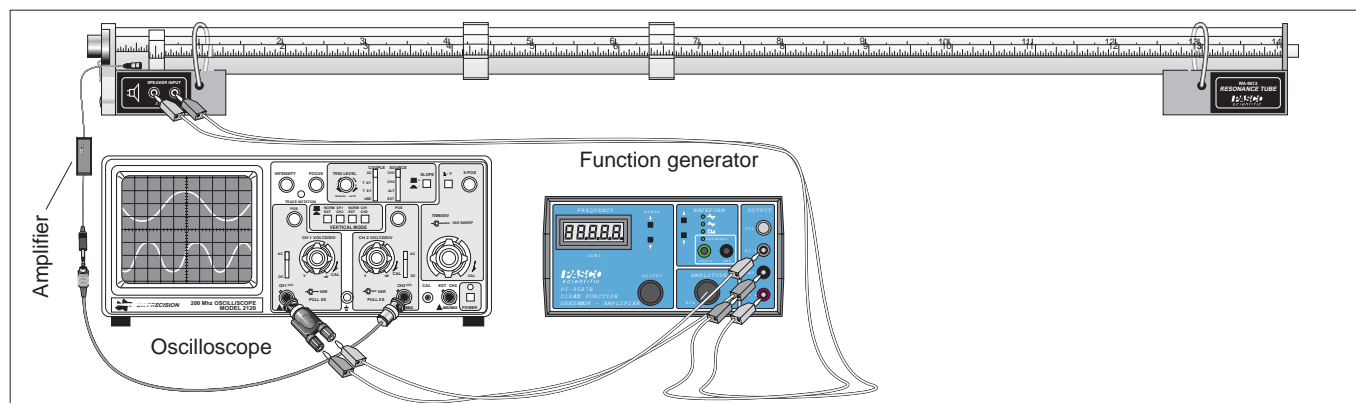

Figure 1.1 Equipment Setup

- ③ Raise the frequency slowly until you find a new resonant frequency. Again measure and record the frequency.
- ④ Continue finding still higher resonant frequencies. Find at least five.
- ⑤ Now close one end of the tube. You can either put the piston in the end of the tube, supporting the rod on some convenient object, or place an object, such as a book, against the end of the tube.
- ⑥ Repeat steps 2-4 for the closed tube, recording your readings in Table 1.2.

TABLE 1.1
Resonant Frequencies for an Open Tube

Frequencies ν	ν/ν_0
$\nu_0 =$	-----

TABLE 1.2
Resonant Frequencies for a Closed Tube

Frequencies ν	ν/ν_0
$\nu_0 =$	-----

Analysis

For each tube configuration (open and closed) divide each of your resonant frequencies (n) by the lowest resonant frequency (n_0) that you were able to find. Your results should give you a series of whole numbers. Record this series for each tube configuration. If you do not get a series of whole numbers, you may not have found the lowest resonant frequency for the tube. If this is the case, try to use your results to determine what the lowest resonant frequency would have been, had you been able to detect it.

Questions

Is the number series you determined the same for both closed and open tubes? Which tube configuration gives a series of consecutive whole numbers? If you have already studied standing wave patterns, try to explain your results in terms of the types of standing wave patterns that are excited in each tube configuration. Is there a node or an antinode at a closed end of the tube? Is there a node or an antinode at an open end of the tube?

Experiment 2: Standing Waves in a Tube

EQUIPMENT NEEDED:

- PASCO Resonance Tube
- Function Generator
- Frequency Counter (if your function generator does not accurately indicate frequency)
- Oscilloscope (recommended, but not necessary)

Introduction

A sound wave propagating down a tube is reflected back and forth from each end of the tube, and all the waves, the original and the reflections, interfere with each other. If the length of the tube and the wavelength of the sound wave are such that all of the waves that are moving in the same direction are in phase with each other, a standing wave pattern is formed. This is known as a resonance mode for the tube and the frequencies at which resonance occurs are called resonant frequencies. In this experiment, you will set up standing waves inside the Resonance Tube and use the miniature microphone to determine the characteristics of the standing waves.

Procedure

- ① Set up the Resonance Tube, oscilloscope, and function generator as shown in Figure 2.1. Turn on the oscilloscope. Set the sweep speed to 5 ms/div and the gain on channel one to approximately 5 mV/div.

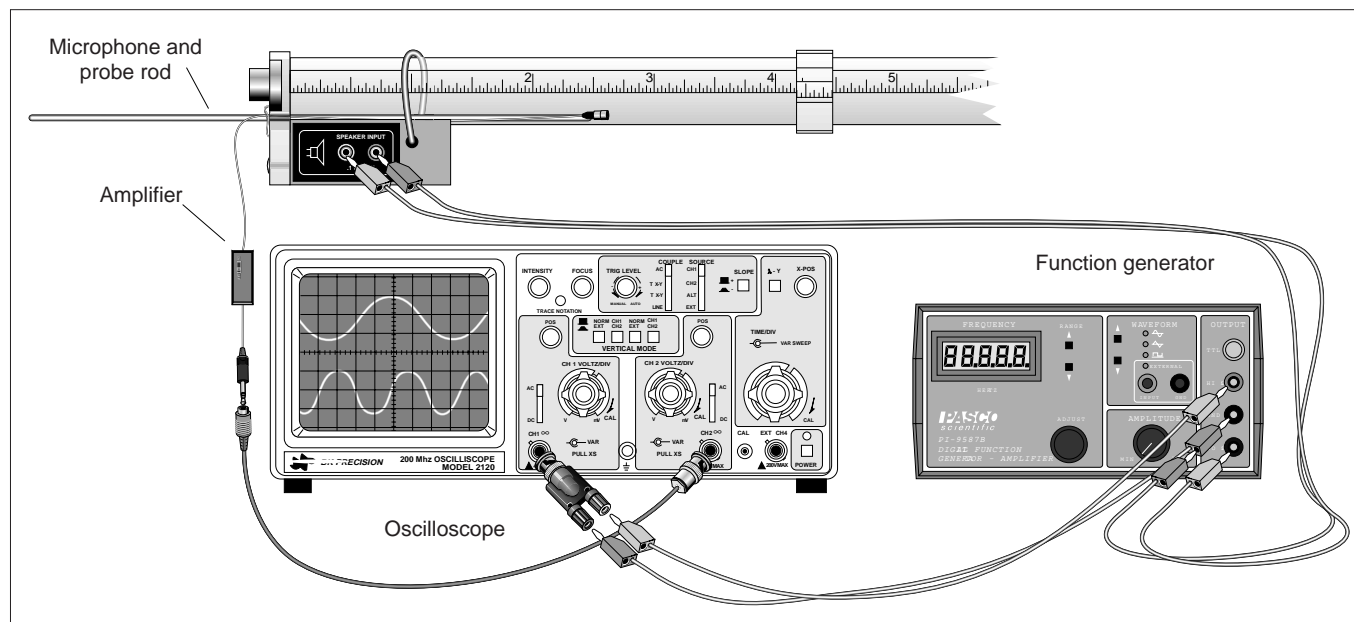

Figure 2.1 Equipment Setup

Turn on the amplifier and the function generator. Set the output frequency of the function generator to approximately 100 Hz. Adjust the amplitude of the function generator until you can distinctly hear the sound from the speaker. If you use the oscilloscope, trigger on the speaker output.

- **WARNING:** You can damage the speaker by overdriving it. The sound from the speaker should be clearly audible, but not loud. Note also that many signal generators become more efficient and thus produce a larger output as the frequency increases, so you may need to reduce the amplitude as you increase the frequency.

- ② Slowly increase the frequency and listen carefully. In general, the sound will become louder as you increase the frequency because the function generator and speaker are more efficient at higher frequencies. However, listen for a relative maximum in the sound level—a frequency where there is a slight decrease in the sound level as you increase the frequency slightly. This relative maximum indicates a resonance mode in the tube. Adjust the frequency carefully to find the lowest frequency at which a relative maximum occurs. (You can also find the relative maximum by watching the trace on the oscilloscope. When the signal height is a relative maximum, you have found a resonant frequency.)

► **NOTE:** It can be difficult to find resonant frequencies at low frequencies (0-300 Hz). If you have trouble with this, try finding the higher frequency resonant modes first, then use your knowledge of resonance modes in a tube to determine the lower resonant frequencies. Be sure to check to make sure that resonance really occurs at those frequencies.

- ③ Mount the microphone on the end of the probe arm and insert it into the tube through the hole in the speaker/microphone stand. As you move the microphone down the length of the tube, note the positions where the oscilloscope signal is a maximum and where it is a minimum. Record these positions in table 2.1. You will not be able to move the probe completely down the tube because the cord is too short. However, you can move the probe around to the opposite end of the tube, to examine the other end of the tube. Pay particular attention to the wave characteristics near the open end of the tube.
- ④ Repeat the above procedure for at least five different resonant frequencies and record your results on a separate sheet of paper.
- ⑤ Insert the piston into the tube, as in Figure 2.2, until it reaches the maximum point that the microphone can reach coming in from the speaker end.

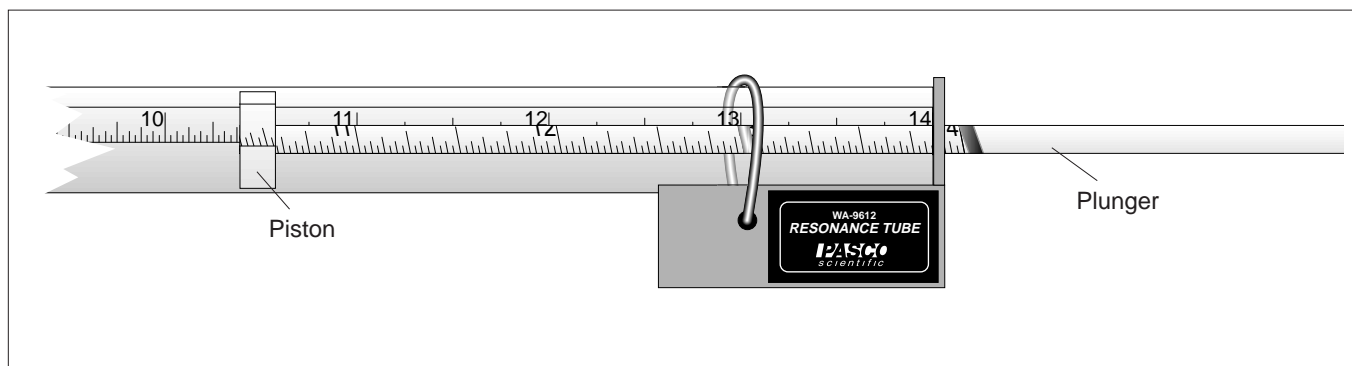

Figure 2.2 Using the Plunger

- ⑥ Find a resonant frequency for this new tube configuration. Use the microphone to locate the maxima and minima for this closed tube configuration, recording your results in table 2.2. Repeat this procedure for several different frequencies.

Analysis

Use the data that you have recorded to sketch the wave activity along the length of your tube for both the open and closed tube at each of the frequencies you used.

The microphone you are using is sensitive to pressure. The maxima are therefore points of maximum pressure and the minima are points of minimum pressure. On your drawings, indicate where the points of maximum and minimum displacement are located.

Determine the wavelength for the waves in at least two of your trials. Given the frequency of the sound wave you used in each configuration, calculate the speed of sound in your tube. How does this agree with the accepted value of $331.5 \text{ m/sec} + .607 T$, where T is the temperature in Celsius degrees?

Describe the nature of the wave behavior at the end of an open tube based on your measurements. Also describe the nature of the waves at a solid obstacle like the face of the piston.

Table 2.1 Open Tube

Resonant Frequency: _____

Microphone Positions	
Maxima	Minima

Table 2.2 Closed Tube

Resonant Frequency: _____

Microphone Positions	
Maxima	Minima

<i>Notes</i>

Experiment 3: Tube Length and Resonant Modes

EQUIPMENT NEEDED:

- PASCO Resonance Tube
- Function Generator
- Frequency Counter (if your function generator does not accurately indicate frequency)
- Oscilloscope (recommended, but not necessary)

Introduction

For any given tube length, there are a variety of resonant frequencies—frequencies at which standing waves will be formed in the tube. Likewise, for a given frequency, there are a variety of tube lengths at which a standing wave will be formed. In this experiment you will examine the series of tube lengths which will resonate with a set frequency.

Procedure

- ① Set up the Resonance Tube, oscilloscope, and function generator as shown in Figure 3.1. Move the piston to a position very near the end of the tube. Set the signal generator to approximately 800 Hz and turn the amplitude up until the speaker is clearly heard. Record this frequency. If you use the oscilloscope, trigger on the speaker output.

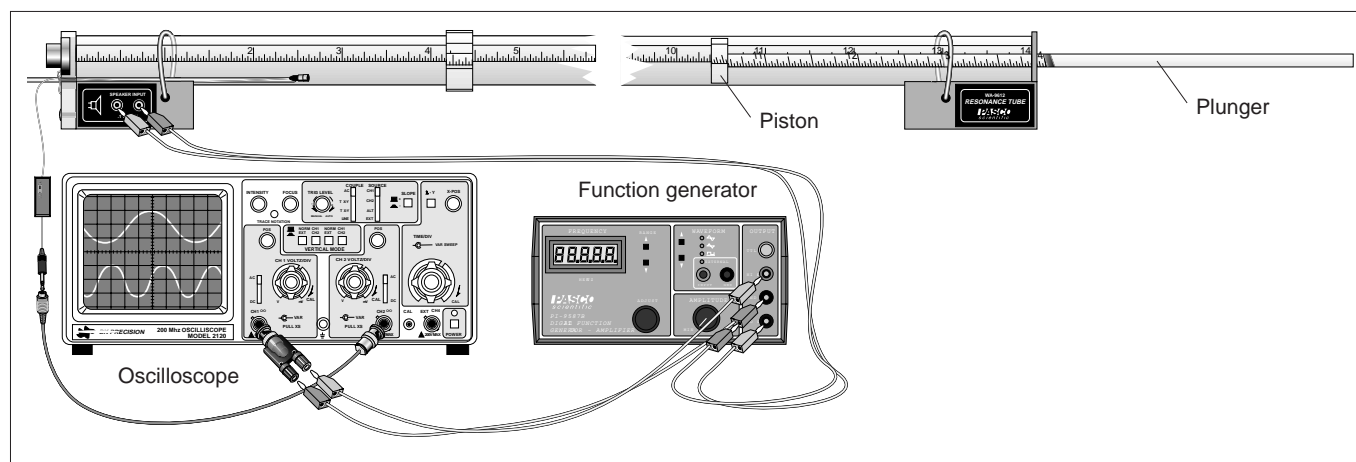

Figure 3.1 Equipment Setup

- **WARNING:** You can damage the speaker by overdriving it. The sound from the speaker should be clearly audible, but not loud. Note also that many signal generators become more efficient and thus produce a larger output as the frequency increases, so if you increase the frequency, you may need to reduce the amplitude.

- ② Slowly push the piston further into the tube, until you hear the sound from the speaker being amplified by the tube, indicating that you have produced a standing wave in the tube. Adjust the piston position carefully until you find the point which produces the loudest sound as well as the largest signal on the oscilloscope screen. Record this position.
- ③ Now continue moving the piston into the tube until you reach a new position where a standing wave is produced. Record this new position. Continue moving the piston until you have found all of the piston positions along the tube which produce standing waves.
- ④ Repeat the procedures above for as many different frequencies as your instructor directs.

Analysis

Use the data that you have recorded to sketch the wave activity along the length of your tube with the piston in the position furthest from the speaker. How do the successive piston positions that produced a standing wave relate to this sketch? Is the apparent spacings of nodes and antinodes consistent with the wavelength of your sound waves as calculated from $\lambda = \mathbf{V}/\nu$, where \mathbf{V} = speed of sound?

Table 3.1 Closed Tube Resonances

Frequency: _____	Frequency: _____	Frequency: _____	Frequency: _____
Piston Positions	Piston Positions	Piston Positions	Piston Positions

Experiment 4: The Speed of Sound in a Tube

EQUIPMENT NEEDED:

- PASCO Resonance Tube
- Function Generator
- Oscilloscope

Introduction

You can determine the speed of sound in a tube from a standing wave pattern. Create a standing wave, then determine the wavelength of the sound from the standing wave pattern. You can then multiply the wavelength by the frequency to determine the speed of the wave ($V = \lambda n$). However, you can also measure the speed of sound more directly. In this experiment you'll measure the speed of sound in the tube by timing a sound pulse as it propagates down the tube and reflects off the end.

Procedure

- ① Set up the Resonance Tube, oscilloscope, and function generator as shown in Figure 4.1. Move the piston near the end of the tube. Set the signal generator to approximately 10 Hz square wave and turn the amplitude up until the speaker is clearly heard making a clicking sound. The oscilloscope should be triggered with the output from the signal generator, or from a trigger output of the generator. When viewed at a frequency roughly equal to the frequency of the signal generator output, the screen should look something like the diagram in Figure 4.2.

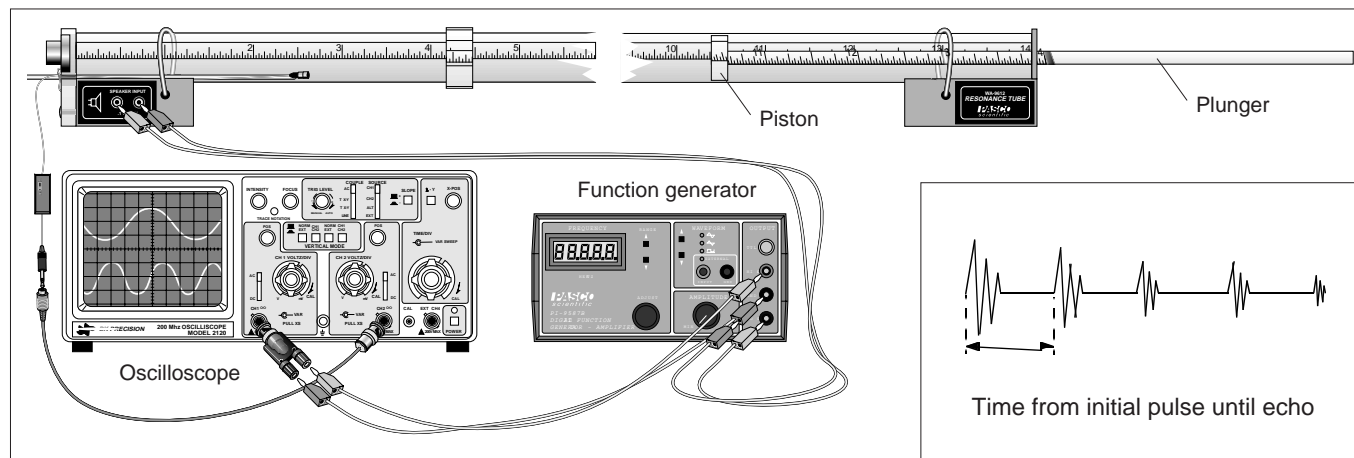

Figure 4.1 Equipment Setup

Figure 4.2 Equipment Setup

- **WARNING:** You can damage the speaker by overdriving it. The sound from the speaker should be clearly audible, but not loud. Note also that many signal generators become more efficient and thus produce a larger output as the frequency increases, so if you increase the frequency, you may need to reduce the amplitude.

- ② Increase the sweep speed of the oscilloscope until you are able to see more clearly the details of the pulses along one part of the square wave. You should see a series of waves generated by the initial ringing of the speaker caused by the sudden voltage increase of the square wave. This will be followed shortly by a similar-looking series of waves representing the returned sound echoing off the face of the piston at the other end of the tube. The oscilloscope trace with the faster sweep speed should look something like the lower diagram in Figure 4.2.

- ③ Determine how far on the screen it is from the initial pulse to the first echo. Record this in table 4.1. Record also the sweep speed setting (the sec/cm setting of the oscilloscope) and the distance from the speaker to the piston.
- ④ Move the piston to a new position. Note that the first echo moves, too. At the new position, record the distance from the speaker to the piston face, the distance from the initial pulse to the echo, and the sweep speed.
- ⑤ Continue moving the piston until you have accumulated at least five sets of data.
- ⑥ Now remove the piston and repeat the experiment with the open tube.
 - Now move the microphone around to the open end of the tube. Determine how long it takes the sound wave to travel from the speaker to the microphone.

Analysis

Use the data that you have recorded to calculate the speed of sound in the closed tube.

Assuming that the speed of sound in the open tube is equal to the speed of sound in the closed tube (a good assumption), how long does the tube appear to be for the open tube? How does this answer compare to the actual length of the tube? Discuss the comparison you just made.

Describe how you might set up an experiment to determine the velocity of sound in air, not in the tube.

TABLE 4.1 Speed of Sound in a Closed Tube

Tube Length	Distance on Scope Screen	Sweep Speed	Speed of Sound

TABLE 4.2 Speed of Sound in an Open Tube

Tube Length	Distance on Scope Screen	Sweep Speed	Speed of Sound

Suggested Demonstration

EQUIPMENT NEEDED:

- PASCO Resonance Tube
- Cork Dust
- Speaker
- Function Generator
- Resonance Tube Plunger

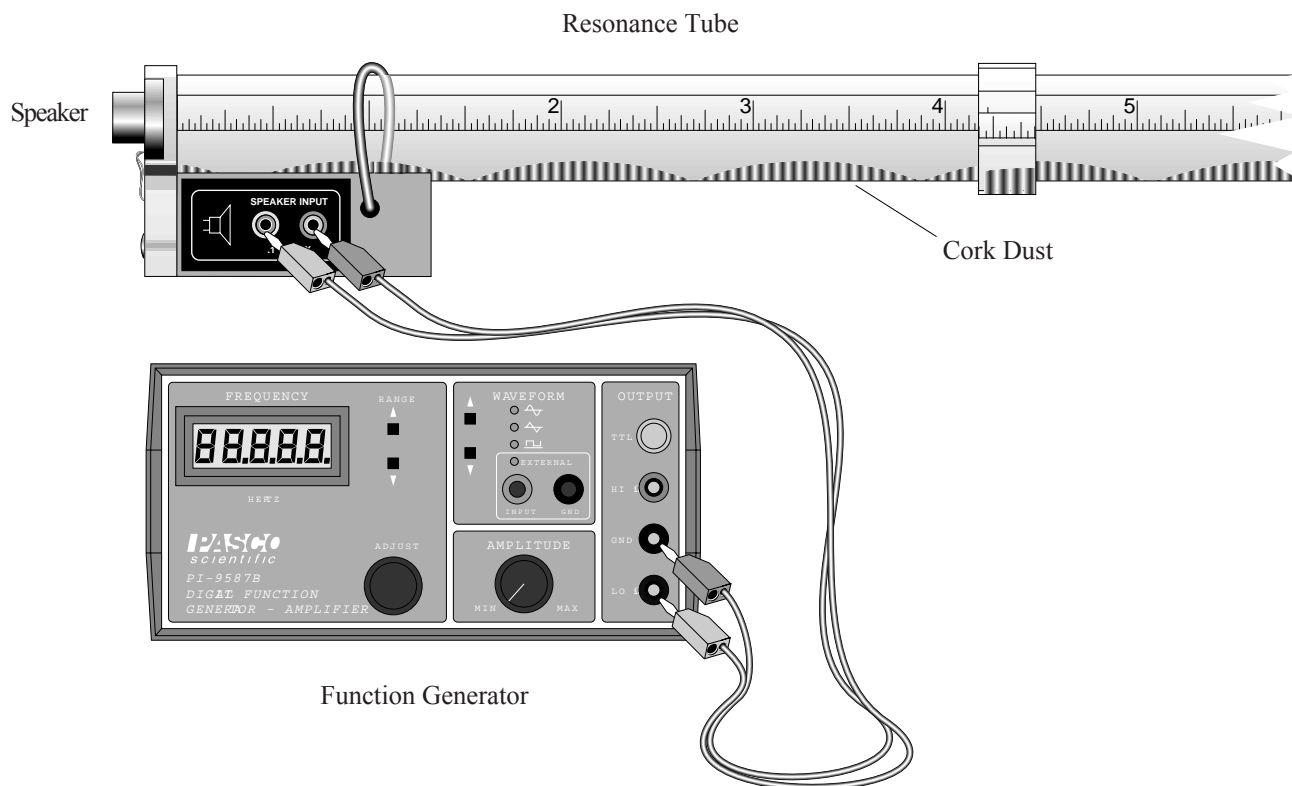

Introduction

Your PASCO WA-9612 Resonance Tube can be used as a Kundt's Tube with some minor modifications. This makes a very effective demonstration for a class or for students working in small groups.

Procedure

- ① Sprinkle a small amount of cork dust evenly along the bottom of the resonance tube. Rotate the tube slightly so the cork dust is positioned slightly up the side of the tube.
- ② Set the speaker at the end of the tube as shown in the diagram. Adjust the amplitude and frequency until you obtain a standing wave in the tube. (Accompanied by a marked increase of amplitude of the sound.) At this point, displacement antinodal areas will show rapid movement of the cork dust, while nodal areas will show no movement.
- ③ You can now adjust the frequency to other standing wave frequencies, or you can put the plunger in one end to observe the difference in closed tube standing waves versus open tube standing waves.

Suggested Research Topics

The following are a few suggestions for further experimentation with the Resonance Tube.

- ① Obtain tubes of different diameters, all made from the same material. Investigate the relationship between tube diameter and the speed of sound in the tube.
- ② Using the same technique as in Experiment 4, measure the speed of sound outside the tube. (This can be a bit tricky. It is particularly important to remove any reflective surfaces that might interfere with the measurement.) How does the speed outside the tube compare with the speed inside the tube?
- ③ Seal the tube and fill it with a gas such as CO_2 , N_2 , or O_2 . Determine the speed of sound in various gases.
- ④ With one end of the tube open, calculate the speed of sound in the tube with air flowing through the tube. This can be done with the flow of air going toward or away from the speaker. The speed of sound as it moves with and against the stream of air leads directly to a discussion of the Michelson-Morley experiment.
- ⑤ Use the holes in the side of the tube to investigate the use of finger stops in musical instruments. How does the open or closed hole effect the fundamental frequency? Does it make a difference if the hole is at a node or antinode of the standing wave pattern?

Teacher's Guide

Experiment 1: Resonant Frequencies of a Tube

Notes on Procedure

- ⑥ The fundamental frequency for the closed tube with the piston in the very end (longest possible closed tube) is about 95 Hz. Because it is difficult to see the resonance at such a low frequency, you may want to make sure that the piston is inserted to at least the 70cm mark.

Notes on Questions

The open-tube number series (1,2,3,4...) contains consecutive integers. The closed-tube series (1,3,5,7...) contains odd integers. This series is a series of the values of n : see theory section.

Notes on Analysis

Open tube		Closed tube	
ν	ν/ν_0	ν	ν/ν_0
185	1.00	94	1.00
369	1.99	282	3.00
555	3.00	473	5.03
740	4.00	663	7.05
918	4.96	852	9.06
1102	5.96	1042	11.09
1271	6.87	1230	13.09
1369	7.40	1434	15.26
1676	9.06	1626	17.30
1870	10.11	1812	19.28
2056	11.11	2006	21.34

There will be some data points which seem to be resonant, but aren't at the theoretical resonant frequencies (Italicized points on the "open tube" data above, for example). On the whole, however, the data should be fairly close to theoretical.

Experiment 2: Standing Waves in a Tube

Notes on Procedure

- ①② If you have already done experiment 1, use the known open-tube resonant frequencies from that experiment.
- ③ The node points near the open ends of the tube may actually be located beyond the ends, outside of the tube.

Notes on Analysis

- ①② The wave activity pattern will be similar to the diagrams in the “theory” section of the manual, except that the microphone detects pressure variation rather than displacement variation. Because of this, the standing wave pattern will be shifted 90° from the pattern shown.

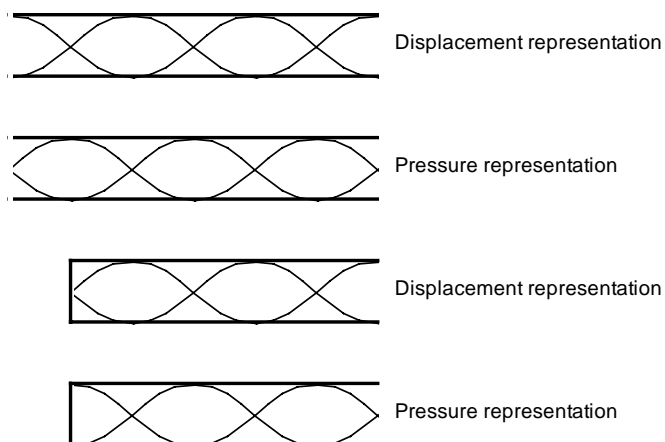

The Theory section of the manual shows the displacement representation for the open and closed tubes; but the microphone will see the pressure representation.

- ③ The velocity of the sound wave inside the tube is theoretically higher than outside the tube; but within the limits of this experiment they will be the same.
- ④ The pressure wave reflects without inversion at the face of the piston. It reflects with an inversion at the open end of the tube.

Experiment 3: Tube Length and Resonant Modes

Notes on Analysis

The successive piston positions correspond to pressure antinode (displacement node) positions. The spacing between these positions is equal to half the wavelength of the sound.

Note

It is possible to measure the speed of sound in the tube very accurately by a variation of this method. Plot the length of the tube as a function of n , where n is the number of antinodes in the standing wave pattern (The graph shown is for the tube with both ends closed.) The slope of this line will be equal to $\lambda/2$, and from this you can find the velocity.

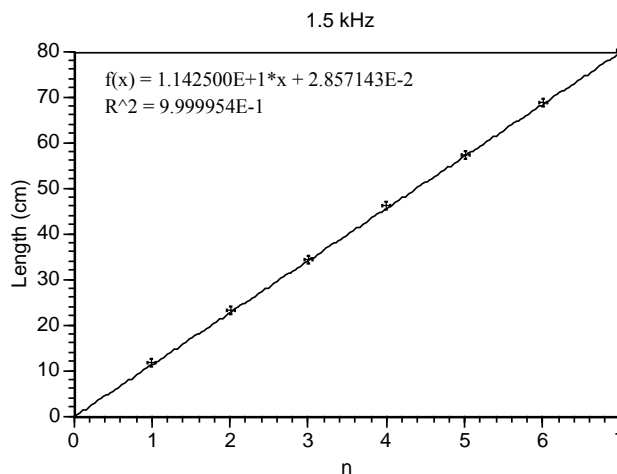

$$v = 342.75 \text{ m/s}$$

Compare with the theoretical value of
 $331.5 + 0.607 T = 342.42 \text{ m/s}$. ($T = 18^\circ\text{C}$)

The intercept is related to the “effective length” of the tube, and will change with frequency.

Experiment 4: The Speed of Sound in a Tube

Procedure

- ① We recommend that you use external triggering on the oscilloscope. You will also have to adjust the triggering level and holdoff in order to get a clean, steady trace on the screen.
- ②⑤ Our measurements gave values of 335-347 m/s, with the variation mostly due to difficulties in measuring the distance between echoes. The trace is not always steady and easy to read.

Analysis

- ① $v \approx 340$ m/s. For better precision, use the method described in the teacher's guide to experiment 3.
- ② We were able to measure this by building a corner-cube reflector out of some scrap lexan sheets and tape. The signal was very weak, though, and practically useless beyond 1m.
- ③ The reflected sound pulse will be inverted when the end of the tube is open; and non-inverted when closed. This indicates—among other things—that the speed of sound inside the tube is faster than outside the tube. (We have not been able to experimentally demonstrate this velocity difference with this apparatus.)

Technical Support

Feed-Back

If you have any comments about this product or this manual please let us know. If you have any suggestions on alternate experiments or find a problem in the manual please tell us. PASCO appreciates any customer feed-back. Your input helps us evaluate and improve our product.

To Reach PASCO

For Technical Support call us at 1-800-772-8700 (toll-free within the U.S.) or (916) 786-3800.

email: techsupp@PASCO.com

Contacting Technical Support

Before you call the PASCO Technical Support staff it would be helpful to prepare the following information:

- If your problem is computer/software related, note:

Title and Revision Date of software.

Type of Computer (Make, Model, Speed).

Type of external Cables/Peripherals.

- If your problem is with the PASCO apparatus, note:

Title and Model number (usually listed on the label).

Approximate age of apparatus.

A detailed description of the problem/sequence of events. (In case you can't call PASCO right away, you won't lose valuable data.)

If possible, have the apparatus within reach when calling. This makes descriptions of individual parts much easier.

- If your problem relates to the instruction manual, note:

Part number and Revision (listed by month and year on the front cover).

Have the manual at hand to discuss your questions.

