

Includes  
Teacher's Notes  
and  
Typical  
Experiment Results



***Instruction Manual and  
Experiment Guide for the  
PASCO scientific Models  
OS-9255A thru OS-9258A***

012-07137B

# ***PRECISION INTERFEROMETER***

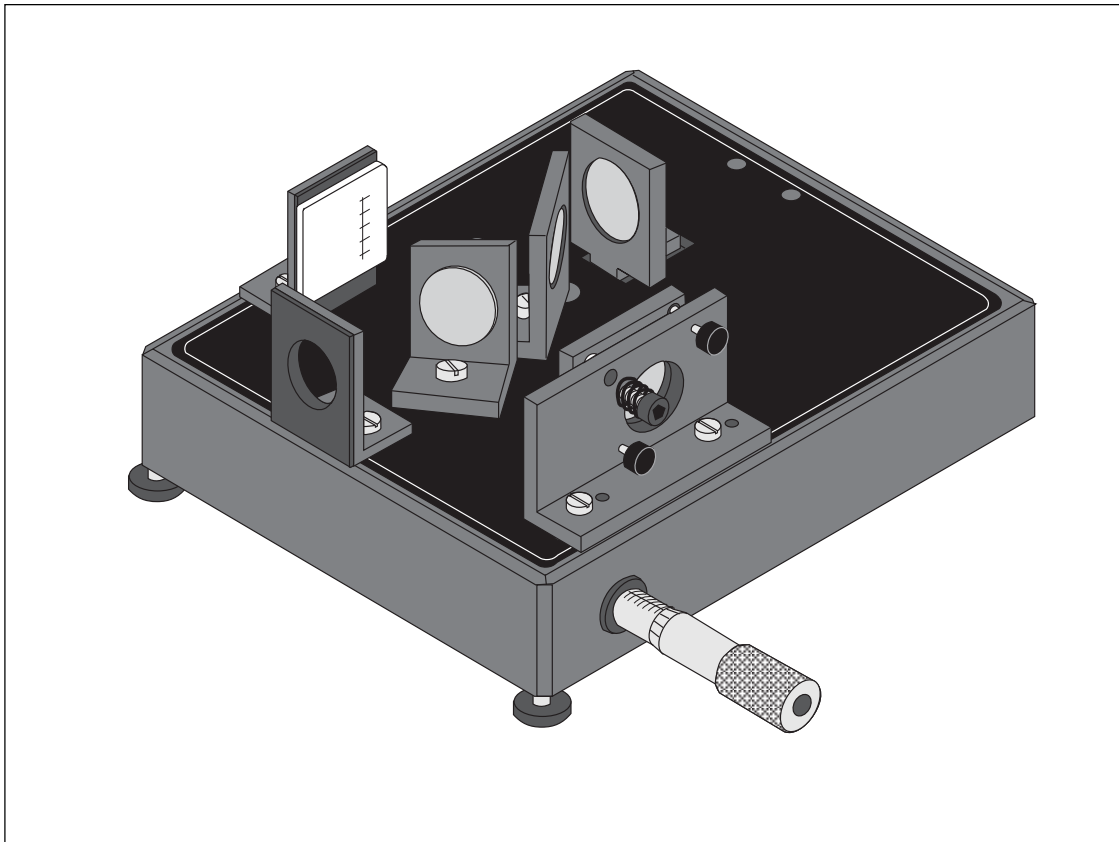

## *Table of Contents*

<b>Section</b>	<b>Page</b>
Copyright, Warranty, and Equipment Return .....	ii-iii
Introduction .....	1
Equipment .....	2
Theory of Operation .....	4
Michelson	
Twyman-Green	
Fabry-Perot	
Setup and Operation .....	6
Tips on Using the Interferometer .....	9
Sources of Error	
Troubleshooting	
Experiments	
Experiment 1: Introduction to Interferometry .....	11
Experiment 2: The Index of Refraction of Air .....	13
Experiment 3: The Index of Refraction of Glass .....	15
Suggestions for Additional Experiments .....	17
Maintenance .....	18
Teacher's Guide .....	20-22

# Copyright, Warranty, and Equipment Return

**Please**—Feel free to duplicate this manual subject to the copyright restrictions below.

## Copyright Notice

The PASCO scientific 012-05187C Precision Interferometer manual is copyrighted and all rights reserved. However, permission is granted to non-profit educational institutions for reproduction of any part of the manual providing the reproductions are used only for their laboratories and are not sold for profit. Reproduction under any other circumstances, without the written consent of PASCO scientific, is prohibited.

## Limited Warranty

PASCO scientific warrants the product to be free from defects in materials and workmanship for a period of one year from the date of shipment to the customer. PASCO will repair or replace at its option any part of the product which is deemed to be defective in material or workmanship. The warranty does not cover damage to the product caused by abuse or improper use. Determination of whether a product failure is the result of a manufacturing defect or improper use by the customer shall be made solely by PASCO scientific. Responsibility for the return of equipment for warranty repair belongs to the customer. Equipment must be properly packed to prevent damage and shipped postage or freight prepaid. (Damage caused by improper packing of the equipment for return shipment will not be covered by the warranty.) Shipping costs for returning the equipment after repair will be paid by PASCO scientific.

## Equipment Return

Should the product have to be returned to PASCO scientific for any reason, notify PASCO scientific by letter, phone, or fax BEFORE returning the product. Upon notification, the return authorization and shipping instructions will be promptly issued.

► **NOTE:** NO EQUIPMENT WILL BE ACCEPTED FOR RETURN WITHOUT AN AUTHORIZATION FROM PASCO.

When returning equipment for repair, the units must be packed properly. Carriers will not accept responsibility for damage caused by improper packing. To be certain the unit will not be damaged in shipment, observe the following rules:

1. The packing carton must be strong enough for the item shipped.
2. Make certain there are at least two inches of packing material between any point on the apparatus and the inside walls of the carton.
3. Make certain that the packing material cannot shift in the box or become compressed, allowing the instrument come in contact with the packing carton.

Address: PASCO scientific  
10101 Foothills Blvd.  
Roseville, CA 95747-7100

Phone: (916) 786-3800  
FAX: (916) 786-3292  
email: techsupp@pasco.com  
web: www.pasco.com

## Introduction

The OS-9255A Precision Interferometer provides both a theoretical and a practical introduction to interferometry. Precise measurements can be made in three modes:

### Michelson

The Michelson Interferometer is historically important, and also provides a simple interferometric configuration for introducing basic principles. Students can measure the wavelength of light and the indices of refraction of air and other substances.

### Twyman-Green

The Twyman-Green Interferometer is an important contemporary tool for testing optical components. It has made it possible to create optical systems that are accurate to within a fraction of a wavelength.

**NOTE:** The PASCO Precision Interferometer is not designed for actual component testing in the Twyman-Green mode. It is intended only to provide a simple introduction to this important application of interferometry.

### Fabry-Perot

The Fabry-Perot Interferometer is also an important contemporary tool, used most often for high resolution spectrometry. The fringes are sharper, thinner, and more widely spaced than the Michelson fringes, so small differences in wavelength can be accurately resolved. The Fabry-Perot interferometer is also important in laser theory, as it provides the resonant cavity in which light amplification takes place.

Switching between these three modes of operation and aligning components is relatively simple, since all mirrors mount to the base in fixed positions, using captive panel screws. Lenses, viewing screens, and other components mount magnetically to the base using the included component holders.

Measurements are precise in all three modes of operation. A 5 kg machined aluminum base provides a stable surface for experiments and measurements. All mirrors are flat to  $1/4$  wavelength, and the built-in micrometer resolves mirror movement to within one micron.

## Equipment

The OS-9255A Precision Interferometer includes the following equipment:

- 5 kg Base with built-in micrometer
- Adjustable Mirror
- Movable Mirror
- Beam Splitter
- Compensator Plate
- (2) Component Holder
- Viewing Screen
- Lens, 18 mm Focal Length
- Diffuser
- Fitted Storage Case

### Additional Equipment Required –

- Laser (OS-9171)
- Laser Bench (OS-9172)

#### NOTE:

The preceding equipment includes everything needed for basic Michelson interferometry. You can produce clear fringes and make precise measurements of the wavelength of your source. However, to perform the experiments in this manual, you will need additional components, such as the OS-9256A Interferometer Accessories or a comparable set of your own components.

The Precision Interferometer is available as a complete system. Please refer to your current PASCO catalog for details.

### Additional Equipment Recommended –

The OS-9256A Interferometer Accessories includes:

- Rotating Pointer
- Vacuum Cell
- Component Holder
- Lens, 18 mm Focal Length
- Lens, 48 mm Focal Length
- Glass Plate
- (2) Polarizer
- Vacuum Pump with Gauge

#### NOTE:

The OS-9255A Fitted Case also provides storage for these accessory components.

### About Your Light Source

We strongly recommend a laser for most introductory applications. A spectral light source can be used (see the Appendix), but that really comprises an experiment in and of itself for beginning students. A laser source is easy to use and produces bright, sharp fringes.

The OS-9171 Laser and OS-9172 Laser Alignment Bench are available from PASCO. However, any low power laser that operates in the visible range will work well. If you want to demonstrate the importance of polarization in interferometry, a non-polarized laser should be used. For easy alignment, the beam should be approximately 4 cm above the level of the bench top.

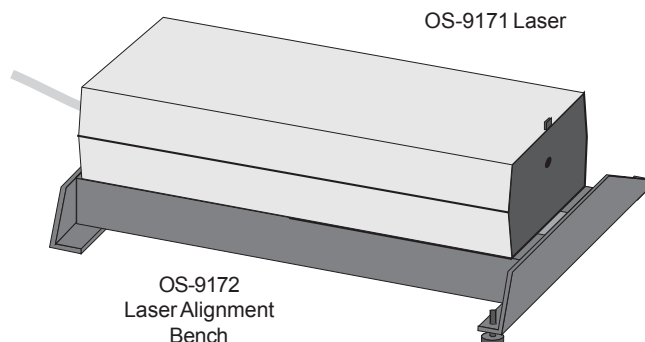

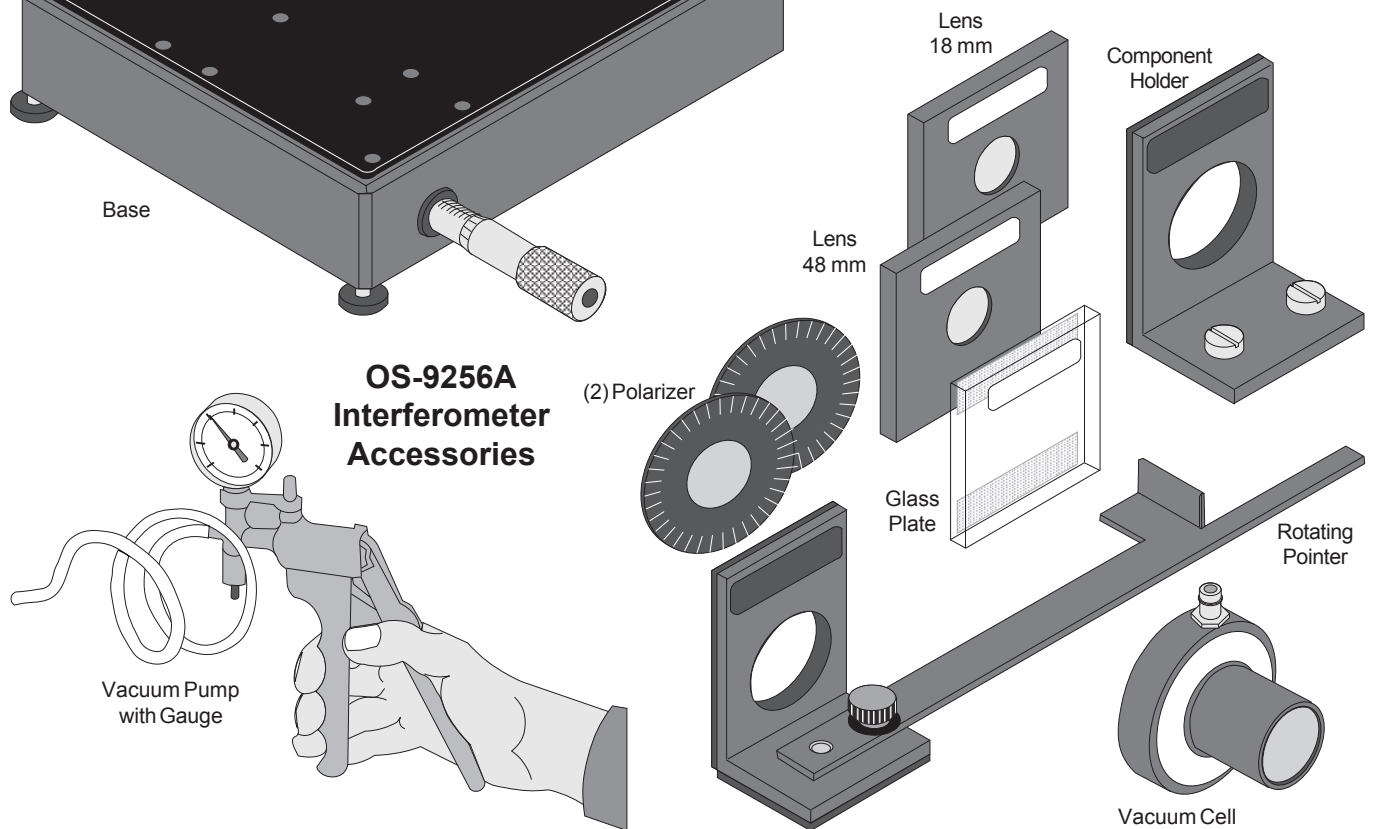
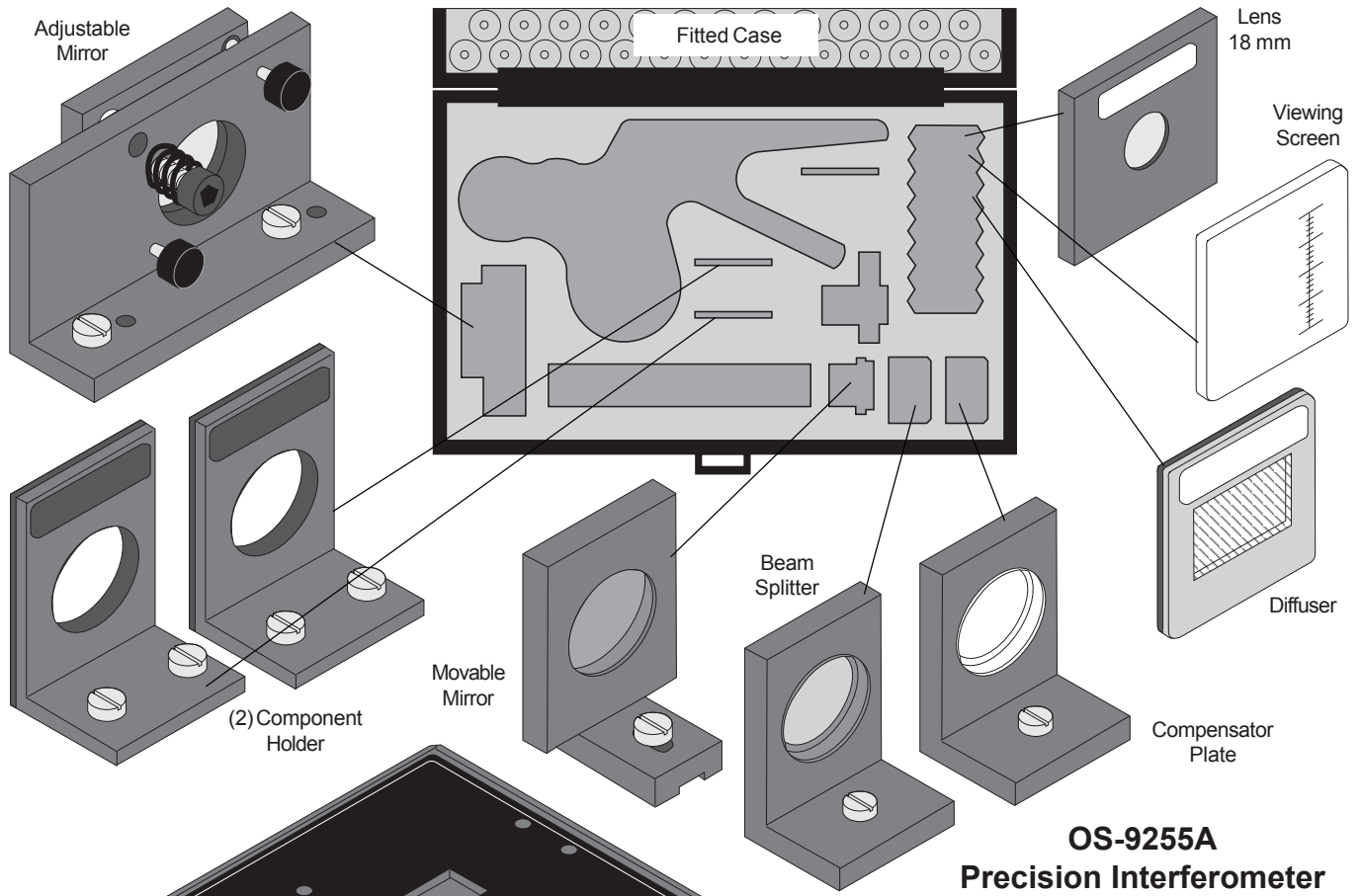

## Theory of Operation

### Interference Theory

A beam of light can be modeled as a wave of oscillating electric and magnetic fields. When two or more beams of light meet in space, these fields add according to the principle of superposition. That is, at each point in space, the electric and magnetic fields are determined as the vector sum of the fields of the separate beams.

If each beam of light originates from a separate source, there is generally no fixed relationship between the electromagnetic oscillations in the beams. At any instant in time there will be points in space where the fields add to produce a maximum field strength. However, the oscillations of visible light are far faster than the human eye can apprehend. Since there is no fixed relationship between the oscillations, a point at which there is a maximum at one instant may have a minimum at the next instant. The human eye averages these results and perceives a uniform intensity of light.

If the beams of light originate from the same source, there is generally some degree of correlation between the frequency and phase of the oscillations. At one point in space the light from the beams may be continually in phase. In this case, the combined field will always be a maximum and a bright spot will be seen. At another point the light from the beams may be continually out of phase and a minima, or dark spot, will be seen.

Thomas Young was one of the first to design a method for producing such an interference pattern. He allowed a single, narrow beam of light to fall on two narrow, closely spaced slits. Opposite the slits he placed a viewing screen. Where the light from the two slits struck the screen, a regular pattern of dark and bright bands appeared. When first performed, Young's experiment offered important evidence for the wave nature of light.

Young's slits can be used as a simple interferometer. If the spacing between the slits is known, the spacing of the maxima and minima can be used to determine the wavelength of the light. Conversely, if the wavelength of the light is known, the spacing of the slits could be determined from the interference patterns.

### The Michelson Interferometer

In 1881, 78 years after Young introduced his two-slit experiment, A.A. Michelson designed and built an interferometer using a similar principle. Originally Michelson designed his interferometer as a means to test for the existence of the ether, a hypothesized medium in which light propagated. Due in part to his efforts, the ether is no longer considered a viable hypothesis. But beyond this, Michelson's interferometer has become a widely used instrument for measuring the wavelength of light, for using the wavelength of a known light source to measure extremely small distances, and for investigating optical media.

Figure 1 shows a diagram of a Michelson interferometer. The beam of light from the laser strikes the beam-splitter, which reflects 50% of the incident light and transmits the other 50%. The incident beam is therefore split into two beams; one beam is transmitted toward the movable mirror ( $M_1$ ), the other is reflected toward the fixed mirror ( $M_2$ ). Both mirrors reflect the light directly back toward the beam-splitter. Half the light from  $M_1$  is reflected from the beam-splitter to the viewing screen and half the light from  $M_2$  is transmitted through the beam-splitter to the viewing screen.

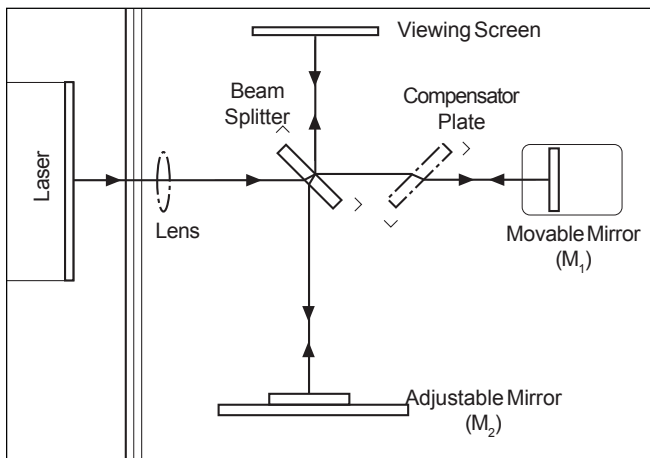

Figure 1. Michelson Interferometer

In this way the original beam of light is split, and portions of the resulting beams are brought back together. Since the beams are from the same source, their phases are highly correlated. When a lens is placed between the laser source and the beam-splitter, the light ray spreads out, and an interference pattern of dark and bright rings, or fringes, is seen on the viewing screen (Figure 2).

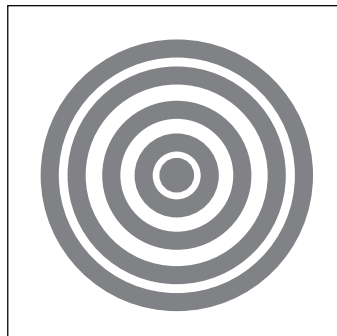

Figure 2. Fringes

Since the two interfering beams of light were split from the same initial beam, they were initially in phase. Their relative phase when they meet at any point on the viewing screen, therefore, depends on the difference in the length of their optical paths in reaching that point.

By moving  $M_1$ , the path length of one of the beams can be varied. Since the beam traverses the path between  $M_1$  and the beam-splitter twice, moving  $M_1$   $1/4$  wavelength nearer the beam-splitter will reduce the optical path of that beam by  $1/2$  wavelength. The interference pattern will change; the radii of the maxima will be reduced so they now occupy the position of the former minima. If  $M_1$  is moved an additional  $1/4$  wavelength closer to the beam-splitter, the radii of the maxima will again be reduced so maxima and minima trade positions, but this new arrangement will be indistinguishable from the original pattern.

By slowly moving the mirror a measured distance  $d_m$ , and counting  $m$ , the number of times the fringe pattern is restored to its original state, the wavelength of the light ( $\lambda$ ) can be calculated as:

$$\lambda = \frac{2d_m}{m}$$

If the wavelength of the light is known, the same procedure can be used to measure  $d_m$ .

#### NOTE: Using the Compensator

In Figure 1, notice that one beam passes through the glass of the beam-splitter only once, while the other beam passes through it three times. If a highly coherent and monochromatic light source is used, such as a laser, this is no problem. With other light sources this is a problem.

The difference in the effective path length of the separated beams is increased, thereby decreasing the coherence of the beams at the viewing screen. This will obscure the interference pattern.

A compensator is identical to the beam-splitter, but without the reflective coating. By inserting it in the beam path, as shown in Figure 1, both beams pass through the same thickness of glass, eliminating this problem.

### The Twyman-Green Interferometer

The Twyman-Green Interferometer is a variation of the Michelson Interferometer that is used to test optical components. A lens can be tested by placing it in the beam path, so that only one of the interfering beams passes through the test lens (see Figure 3). Any irregularities in the lens can be detected in the resulting interference pattern. In particular, spherical aberration, coma, and astigmatism show up as specific variations in the fringe pattern.

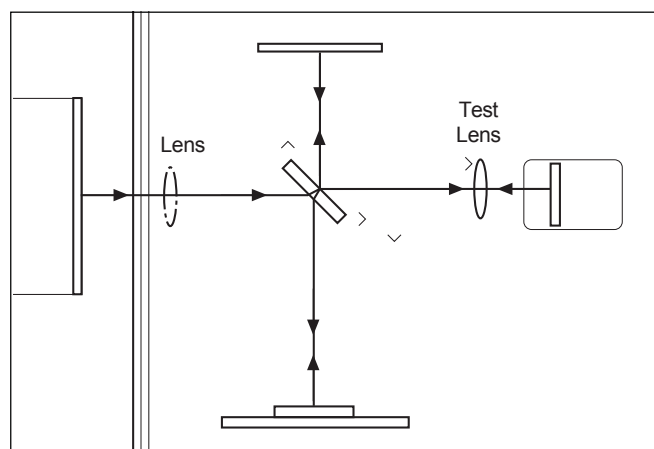

Figure 3. Twyman-Green Interferometer



## The Fabry-Perot Interferometer

In the Fabry-Perot Interferometer, two partial mirrors are aligned parallel to one another, forming a reflective cavity. Figure 4 shows two rays of light entering such a cavity and reflecting back and forth inside. At each reflection, part of the beam is transmitted, splitting each incident ray into a series of rays. Since the transmitted rays are all split from a single incident ray, they have a constant phase relationship (assuming a sufficiently coherent light source is used).

The phase relationship between the transmitted rays depends on the angle at which each ray enters the cavity and on the distance between the two mirrors. The result is a circular fringe pattern, similar to the Michelson pattern, but with fringes that are thinner, brighter, and more widely spaced. The sharpness of the Fabry-Perot fringes makes it a valuable tool in high-resolution spectrometry.

As with the Michelson Interferometer, as the movable

mirror is moved toward or away from the fixed mirror, the fringe pattern shifts. When the mirror movement is equal to  $1/2$  of the wavelength of the light source, the new fringe pattern is identical to the original.

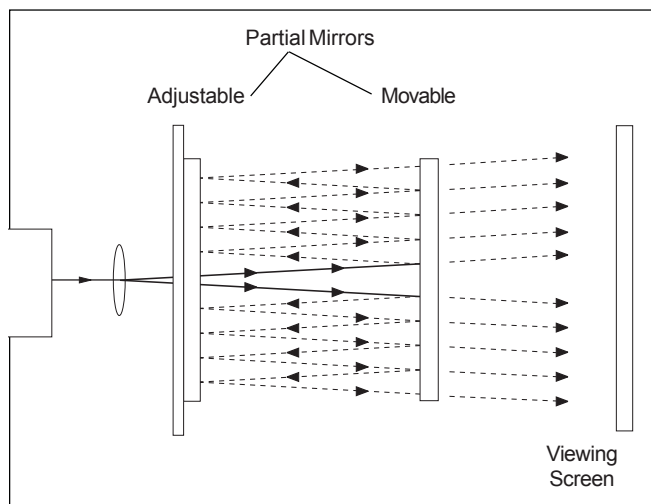

Figure 4. Fabry-Perot Interferometer

## Setup and Operation

### Laser Alignment

- If you are using a PASCO Laser and Laser Alignment Bench, the setup and alignment procedure is as follows.
- If you are using a different laser, the alignment procedure is similar. Adjust your laser so that the beam is approximately 4 cm above the table top. Then align the beam as in steps 4 and 5, below.
- If you are using a spectral light source instead of a laser, see *Suggestions for Additional Experiments*, near the end of the manual.

### To set up and align your PASCO Laser:

1. Set the interferometer base on a lab table with the micrometer knob pointing toward you.
2. Position the laser alignment bench to the left of the base approximately perpendicular to the interferometer base and place the laser on the bench.
3. Secure the movable mirror in the recessed hole in the interferometer base.
4. Turn the laser on. Using the leveling screws on the laser bench, adjust its height until the laser beam is approximately parallel with the top of the interferometer base and strikes the movable mirror in the center. (To check that the beam is parallel with the base, place a piece of paper in the beam path, with the edge of the paper flush against the base. Mark the height of the beam on the paper. Using the piece of paper, check that the beam height is the same at both ends of the bench.)
5. Adjust the X-Y position of the laser until the beam is reflected from the movable mirror right back into the laser aperture. This is most easily done by gently sliding the rear end of the laser transverse to the axis of the alignment bench, as shown in Figure 5.

You are now ready to set up the interferometer in any of its three modes of operation.

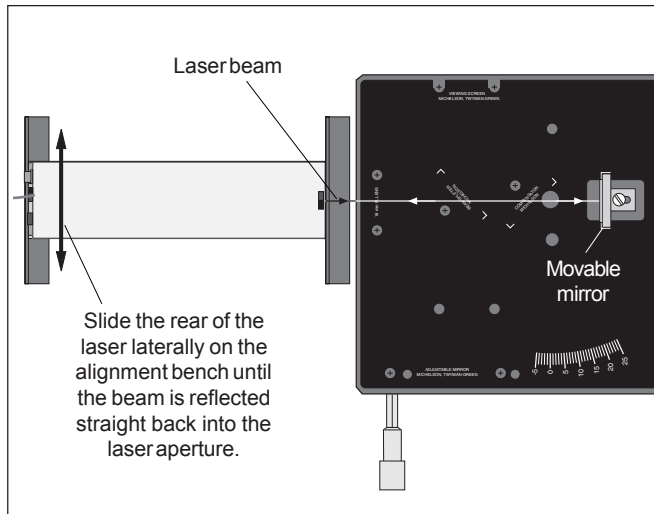

**Figure 5. Aligning the Laser**

**NOTE:**

For ease of installation the placement of the individual components in the various modes is indicated on the label.

### Michelson Mode

1. Align the laser and interferometer base as previously described. The laser beam should be approximately parallel with the top of the base, should strike the center of the movable mirror, and should be reflected directly back into the laser aperture.
2. Mount the adjustable mirror on the interferometer base. Position one component holder in front of the laser. Place the other component holder opposite the adjustable mirror and attach the viewing screen to its magnetic backing. See Figure 6.
3. Position the beam-splitter at a 45 degree angle to the laser beam, within the crop marks, so that the beam is reflected to the fixed mirror. Adjust the angle of the beam-splitter as needed so that the reflected beam hits the fixed mirror near its center.
4. There should now be two sets of bright dots on the viewing screen; one set comes from the fixed mirror and the other comes from the movable mirror. Each set of dots should include a bright dot with two or more dots of lesser brightness (due to multiple reflections). Adjust the angle of the beam-splitter again until the two sets of dots are as close together as possible, then tighten the thumbscrew to secure the beam-splitter.
5. Using the thumbscrews on the back of the adjustable mirror, adjust the mirror's tilt until the two sets of dots on the viewing screen coincide.
6. The compensator is not needed for producing interference fringes when using a laser light source. However, if you wish to use the compensator, it mounts perpendicular to the beam-splitter, as shown.
7. Attach the 18 mm FL lens to the magnetic backing of the component holder in front of the laser, as shown, and adjust its position until the diverging beam is centered on the beam-splitter. You should now see circular fringes on the viewing screen. If not, carefully adjust the tilt of the adjustable screen until the fringes appear.
8. If you have trouble obtaining fringes, see *Troubleshooting* at the end of this section.

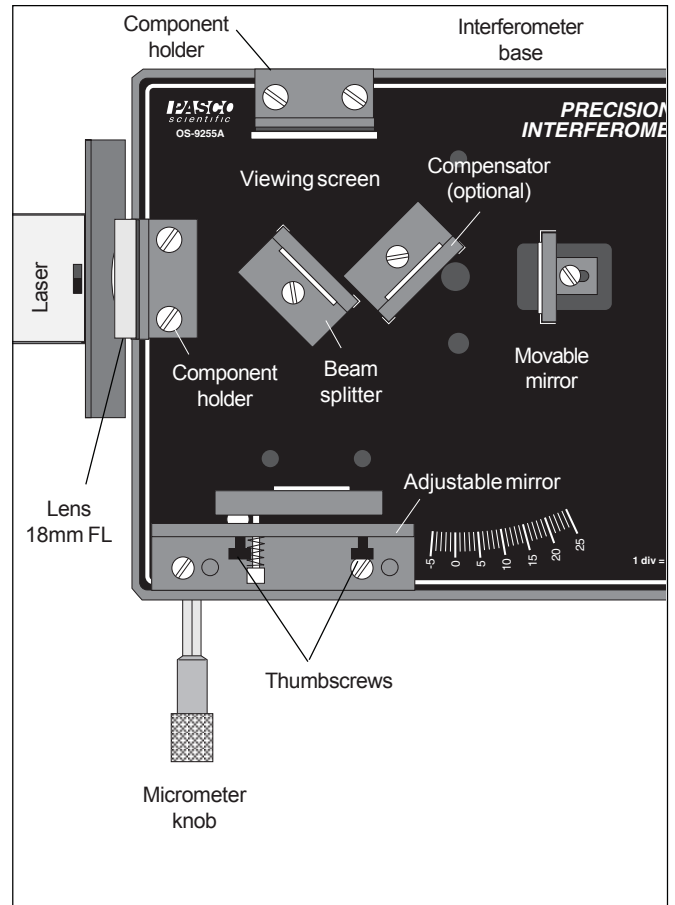

**Figure 6. Michelson Mode Setup**

## Twyman-Green Mode

1. Set up the interferometer in the Michelson mode, as described above.
2. Remove the pointer from the rotational component holder. (It is recommended to store the pointer, washer and thumbscrew in the storage case.) Place the component holder between the beam-splitter and the movable mirror (see Figure 7). It attaches magnetically. Mount a second 18 mm FL lens ( $L_2$ ) on its magnetic backing and position it.

3. Remove the original lens ( $L_1$ ) from in front of the laser.

Observe the two sets of dots on the viewing screen—one set from the movable mirror and one set from the adjustable mirror. Adjust the position of  $L_2$  until both sets of dots are the same size.

4. Adjust the tilt of the adjustable mirror until the two sets of dots coincide.
5. Replace lens  $L_1$  in front of the laser. Move the viewing screen so it's at least 12 inches from the edge of the interferometer base. Fringes should appear in the bright disk of the viewing screen. Fine adjustments of  $L_1$  may be necessary to find the fringes. A piece of white paper or cardboard can be used in place of the viewing screen. A 48 mm FL convex lens may also be used to magnify the projected image of the fringes.

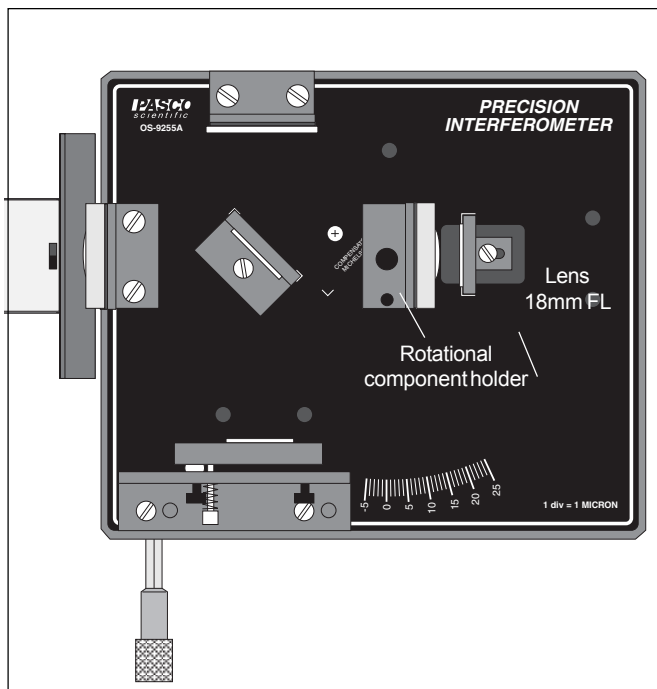

Figure 7. Twyman-Green Mode Setup

## Fabry-Perot Mode

1. Align the laser and interferometer base as described in *Laser Alignment* at the beginning of this section. The laser beam should be approximately parallel with the top of the base, should strike the center of the movable mirror, and should be reflected directly back into the laser aperture.
2. Mount the adjustable mirror where indicated on the interferometer base and one component holder in front of the movable mirror. See Figure 8.
3. Place the other component holder behind the movable mirror and attach the viewing screen to its magnetic backing. You should see several images of the laser beam on the viewing screen.
4. Using the thumbscrews, adjust the tilt of the adjustable mirror until there is only one bright dot on the screen.
5. Now mount the 18 mm FL lens on the front component holder. A clear sharp interference pattern should be visible on the viewing screen. If you use light with two component wavelengths, instead of a laser, two sets of fringes can be distinguished on the viewing screen.

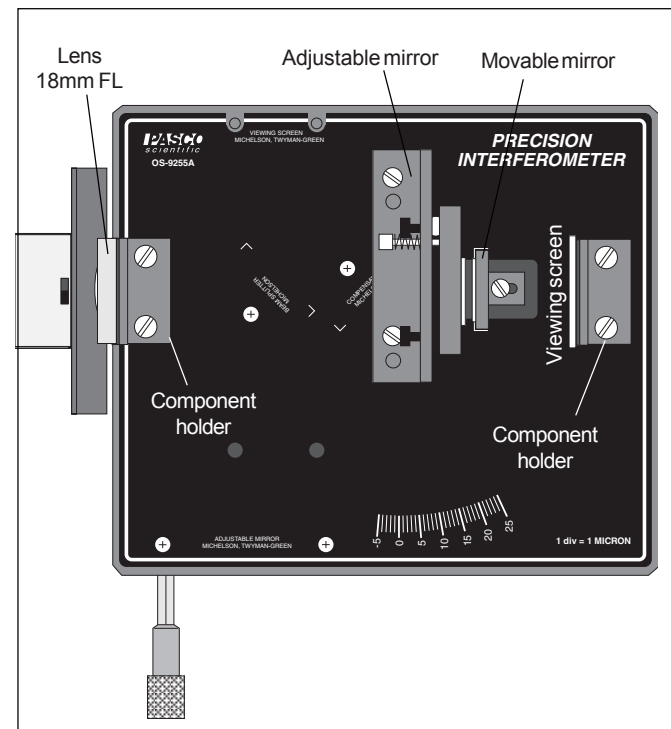

Figure 8. Fabry-Perot Mode Setup

## Tips on Using the Interferometer

### Accurate Fringe-Counting

The following techniques can help you make accurate measurements.

1. It's not necessary that your interference pattern be perfectly symmetrical or sharp. As long as you can clearly distinguish the maxima and minima, you can make accurate measurements.
2. It's easy to lose track when counting fringes. The following technique can help.

Center the interference pattern on the viewing screen using the thumb-screws on the back of the fixed mirror. Select a reference line on the millimeter scale and line it up with the boundary between a maxima and a minima (see Figure 9).

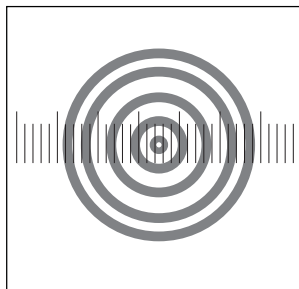

**Figure 9.**  
**Counting Fringes**

Move the micrometer dial until the boundary between the next maximum and minimum reaches the same position as the original boundary. (The fringe pattern should look the same as in the original position.) One fringe has gone by.

3. When turning the micrometer dial to count fringes, always turn it one complete revolution before you start counting, then continue turning it in the same direction while counting. This will almost entirely eliminate errors due to backlash in the micrometer movement.

Backlash is a slight slippage that always occurs when you reverse the direction of motion in a mechanical instrument. (Turning the micrometer dial clockwise moves the movable mirror toward the right. Turning the dial counter-clockwise moves the mirror toward the left.) The PASCO micrometer is designed to minimize backlash. However, by using the technique described above, you can practically eliminate all effects of backlash in your measurements.

4. Always take several readings and average them for greater accuracy.

5. The slip ring at the base of the micrometer knob adjusts the tension in the dial. Before making a measurement, be sure the tension is adjusted to give you the best possible control over the mirror movement.

### Calibrating the Micrometer

For even more accurate measurements of the mirror movement, you can use a laser to calibrate the micrometer. To do this, set up the interferometer in Michelson or Fabry-Perot mode. Turn the micrometer knob as you count off at least 20 fringes. Carefully note the change in the micrometer reading, and record this value as  $d'$ . The actual mirror movement,  $d$ , is equal to  $N\lambda/2$ , where  $\lambda$  is the known wavelength of the light ( $0.6328 \mu\text{m}$  for a standard helium-neon laser) and  $N$  is the number of fringes that were counted. In future measurements, multiply your micrometer readings by  $d/d'$  for a more accurate measurement.

**NOTE:** You can also adjust the micrometer calibration mechanically. The process is not difficult, but for most accurate results, the above procedure is still recommended. See the *Maintenance* section at the end of the manual for the mechanical calibration procedure.

### Demonstrations

The PASCO interferometer is not designed for large demonstrations. However, for small demonstrations, you can use the 48 mm focal length lens (included in the Interferometer Accessories) to magnify the fringe pattern and project it onto a wall or screen. It is helpful to have a powerful laser for large projections.

### Using the Diffuser

It's sometimes more convenient to view the interference pattern through the diffuser rather than on the viewing screen. Just place the diffuser where you would normally place the viewing screen, and look through it toward the interferometer.

## Sources of Experimental Error

**Backlash**—Although PASCO's carefully designed mirror movement reduces backlash considerably, every mechanical system is susceptible to backlash. However, the effects of backlash can be practically eliminated by using proper technique when counting fringes (see item 3 under Accurate Fringe-Counting, on the previous page).

**Mirror Travel**—The amount of mirror movement per dial turn of the micrometer is constant to within 1.5%. Most of this error occurs at the extreme ends of the mirror's total possible movement. For very accurate measurements, see *Calibrating the Micrometer*, above, and remember that the mirrors are flat to within 1/4 wavelength across their surface.

## Troubleshooting

If you have trouble producing a clear set of interference fringes, consider the following possible sources of difficulty:

1. **Warm up your Laser**—Many lasers vary in intensity and/or polarization as they warm up. To eliminate any possible fringe or intensity variations, allow the laser to warm up prior to setting up an experiment. (The PASCO laser should warm up in about 1 hour.)
2. **Check your Mirrors**—The beam-splitter and movable mirror are carefully mounted in their brackets to remain perpendicular to the interferometer base when set up. If the brackets are bent slightly out of alignment, the resulting fringe patterns will be distorted somewhat. If they are significantly out of alignment, it may be impossible to obtain fringes.
3. **Background Fringes**—Reflections from the front and back surfaces of the mirrors and beam-splitter often cause minor interference patterns in the background of the main fringe pattern. These background patterns normally do not move when the mirror is moved, and have no impact on measurements made using the main interference pattern.
4. **Convection Currents**—If the fringe pattern appears to wave or vibrate, check for air currents. Even a slight breeze can effect the fringes.
5. **Vibration**—Under normal conditions, the interferometer base and mirror mounts are stable enough to provide a vibration free setup. However, if the experiment table is vibrating sufficiently, it will effect the interference pattern.

**IMPORTANT:** If the movable mirror doesn't move when you turn the micrometer dial, see *Micrometer Spacer Replacement* in the *Maintenance* section at the end of this manual.

## Component Specifications

**Interferometer Mirrors**—3.175 cm in diameter; 0.635 + 0.012 cm thick; flat to 1/4 wavelength on both sides; coated on one side for 80% reflectance and 20% transmission.

**Beam-Splitter**—3.175 cm in diameter; 0.635 + 0.012 cm thick; flat to 1/4 wavelength on both sides; coated on one side for 50% reflectance and 50% transmission.

**Compensator**—Identical to the beam-splitter, but uncoated.

**Movable Mirror**—movement is controlled by the micrometer that is built-into the interferometer base; turning the dial clockwise moves the mirror toward the right (looking from the micrometer side); 25 microns per micrometer dial revolution ( $\pm 1\%$  near center of movement); movement through full distance of travel is linear to within 1.5%.

**IMPORTANT:** Avoid touching all mirror surfaces. Minute scratches and dirt can impair the clarity of interference images. See the *Maintenance* section at the end of this manual for cleaning instructions.

## Experiment 1: Introduction to Interferometry

### EQUIPMENT NEEDED:

- Basic Interferometer (OS-9255A)
- Laser (OS-9171)
- Laser Alignment Bench (OS-9172)
- Interferometer Accessories (OS-9256A)  
Component Holder, (2) Calibrated Polarizers

### Introduction

In general, an interferometer can be used in two ways. If the characteristics of the light source are accurately known (wavelength, polarization, intensity), changes in the beam path can be introduced and the effects on the interference pattern can be analyzed. Experiments 2 and 3 are examples of this procedure. On the other hand, by introducing specific changes in the beam path, information can be obtained about the light source that is being used.

In this experiment, you'll use the interferometer to measure the wavelength of your light source. If you have a pair of polarizers, you can also investigate the polarization of your source.

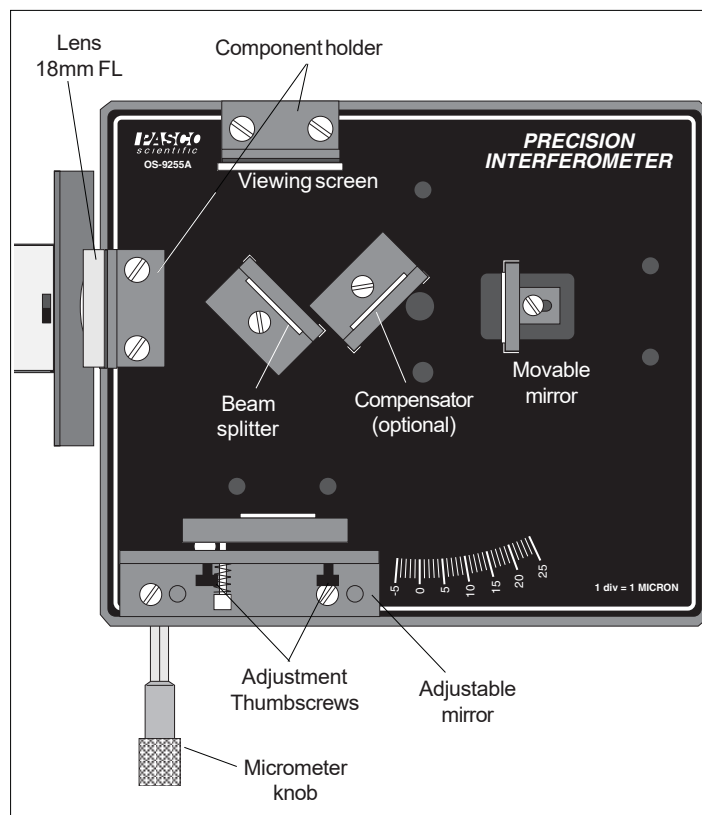

Figure 1.1. Michelson Mode Setup

### Procedure

#### Part I: Wavelength

1. Align the laser and interferometer in the Michelson mode, so an interference pattern is clearly visible on your viewing screen. See *Setup and Operation* for instructions.
2. Adjust the micrometer knob to a medium reading (approximately 50  $\mu\text{m}$ ). In this position, the relationship between the micrometer reading and the mirror movement is most nearly linear.
3. Turn the micrometer knob one full turn counterclockwise. Continue turning counterclockwise until the zero on the knob is aligned with the index mark. Record the micrometer reading.

► **NOTE:** When you reverse the direction in which you turn the micrometer knob, there is a small amount of give before the mirror begins to move. This is called mechanical backlash, and is present in all mechanical systems involving reversals in direction of movement. By beginning with a full counterclockwise turn, and then turning only counterclockwise when counting fringes, you can eliminate errors due to backlash.

4. Adjust the position of the viewing screen so that one of the marks on the millimeter scale is aligned with one of the fringes in your interference pattern. You will find it easier to count the fringes if the reference mark is one or two fringes out from the center of the pattern.
5. Rotate the micrometer knob slowly counterclockwise. Count the fringes as they pass your reference mark. Continue until some predetermined number of fringes have passed your mark (count *at least* 20 fringes). As you finish your count, the fringes should be in the same position with respect to your reference mark as they were when you started to count. Record the final reading of the micrometer dial.

6. Record  $d_m$ , the distance that the movable mirror moved toward the beam-splitter according to your readings of the micrometer knob. Remember, each small division on the micrometer knob corresponds to one  $\mu\text{m}$  ( $10^{-6}$  meters) of mirror movement.
7. Record  $N$ , the number of fringe transitions that you counted.
8. Repeat steps 3 through 7 several times, recording your results each time.
9. Go on to part two. If you have time afterward, try setting up the interferometer in Fabry-Perot mode and repeating steps 3 through 8.

**Part II : Polarization (using the Calibrated Polarizer, part of OS-9256A Interferometer Accessories)**

1. Place a polarizer between the laser and the beam-splitter. Try several polarization angles. How does this effect the brightness and clarity of the fringe pattern?
2. Remove that polarizer and place a polarizer in front of the fixed or movable mirror. Try several polarization angles. How does this effect the fringe pattern?
3. Now try two polarizers, one in front of the fixed mirror, and one in front of the movable mirror. First rotate one polarizer, then the other. Again, note the effects.

## Analysis

### Part I

1. For each trial, calculate the wavelength of the light ( $\lambda = 2d_m / N$ ), then average your results. If you tried the Fabry-Perot mode also, calculate the wavelength independently for that data. The same formula applies.

### Part II

1. From your observations in step 1 of the procedure, can you determine the polarization characteristics of your light source? Does it vary with time?
2. Do your observations from step 2 give you any more information about the polarization of your source?
3. From your observations in step 3, do cross-polarized beams interfere?

## Questions

1. In the calculation to determine the value of  $\lambda$  based on the micrometer movement, why was  $d_m$  multiplied by two?
2. Why move the mirror through many fringe transitions instead of just one? Why take several measurements and average the results?
3. If you tried the Fabry-Perot mode, was your measured  $\lambda$  the same? If not, can you speculate about possible reasons for the difference? Do you have more confidence in one value as opposed to the other?
4. If the wavelength of your light source is accurately known, compare your results with the known value. If there is a difference, to what do you attribute it?
5. When measuring mirror movement using the micrometer dial on the interferometer, what factors limit the accuracy of your measurement?
6. When measuring mirror movement by counting fringes using a light source of known wavelength, what factors might limit the accuracy of your measurement?
7. What role does polarization play in producing an interference pattern?

## Experiment 2: The Index of Refraction of Air

### EQUIPMENT NEEDED:

- Basic Interferometer (OS-9255A)
- Laser (OS-9171)
- Laser Alignment Bench (OS-9172)
- Interferometer Accessories (OS-9256A)
  - Rotational pointer, Vacuum cell, Vacuum pump

### Introduction

In the Michelson interferometer, the characteristics of the fringe pattern depend on the phase relationships between the two interfering beams. There are two ways to change the phase relationships. One way is to change the distance traveled by one or both beams (by moving the movable mirror, for example). Another way is to change the medium through which one or both of the beams pass. Either method will influence the interference pattern. In this experiment you will use the second method to measure the index of refraction for air.

For light of a specific frequency, the wavelength  $\lambda$  varies according to the formula:

$$\lambda = \lambda_0/n;$$

where  $\lambda_0$  is the wavelength of the light in a vacuum, and  $n$  is the index of refraction for the material in which the light is propagating. For reasonably low pressures, the index of refraction for a gas varies linearly with the gas pressure. Of course for a vacuum, where the pressure is zero, the index of refraction is exactly 1. A graph of index of refraction versus pressure for a gas is shown in Figure 2.1. By experimentally determining the slope, the index of refraction of air can be determined at various pressures.

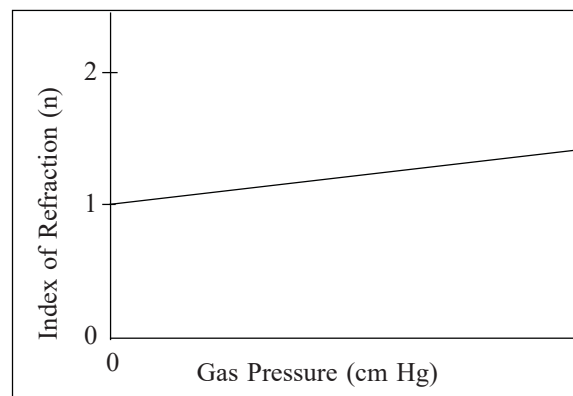

Figure 2.1. Index of Refraction versus Gas Pressure

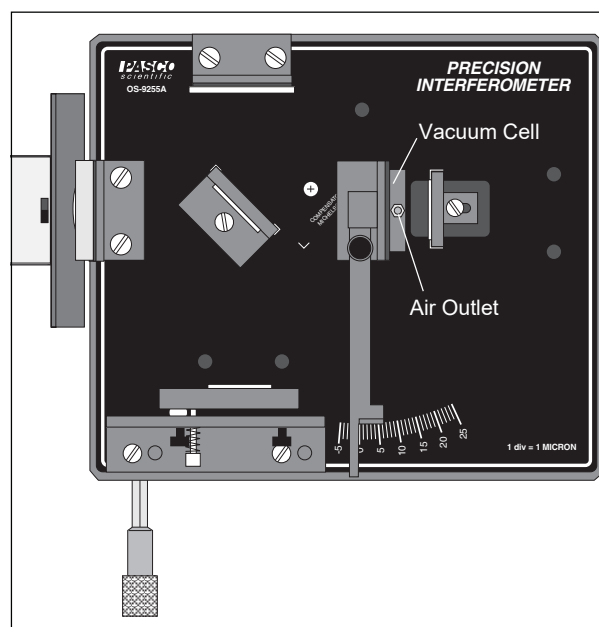

Figure 2.2. Equipment Setup

### Procedure

1. Align the laser and interferometer in the Michelson mode. See *Setup and Operation*.
2. Place the rotational pointer between the movable mirror and the beam-splitter (see Figure 2.2). Attach the vacuum cell to its magnetic backing and push the air hose of the vacuum pump over the air outlet hole of the cell. Adjust the alignment of the fixed mirror as needed so the center of the interference pattern is clearly visible on the viewing screen. (The fringe pattern will be somewhat distorted by irregularities in the glass end-plates of the vacuum cell. This is not a problem.)
3. For accurate measurements, the end-plates of the vacuum cell must be perpendicular to the laser beam. Rotate the cell and observe the fringes. Based on your observations, how can you be sure that the vacuum cell is properly aligned?



4. Be sure that the air in the vacuum cell is at atmospheric pressure. If you are using the OS-8502 Hand-Held Vacuum Pump, this is accomplished by flipping the vacuum release toggle switch.
5. Record  $P_i$ , the initial reading on the vacuum pump gauge. Slowly pump out the air in the vacuum cell. As you do this, count  $N$ , the number of fringe transitions that occur. When you're done, record  $N$  and also  $P_f$ , the final reading on the vacuum gauge. (Some people prefer to begin with the vacuum cell evacuated, then count fringes as they let the air slowly out. Use whichever method is easier for you.)

► **NOTE:** Most vacuum gauges measure pressure with respect to atmospheric pressure (i.e., 34 cm Hg means that the pressure is 34 cm Hg below atmospheric pressure, which is  $\sim 76$  cm Hg). The actual pressure inside the cell is:

$$P_{\text{absolute}} = P_{\text{atmospheric}} - P_{\text{gauge}}$$

## Analyzing Your Data

As the laser beam passes back and forth between the beam-splitter and the movable mirror, it passes twice through the vacuum cell. Outside the cell the optical path lengths of the two interferometer beams do not change throughout the experiment. Inside the cell, however, the wavelength of the light gets longer as the pressure is reduced.

Suppose that originally the cell length,  $d$ , was 10 wavelengths long (of course, it's much longer). As you pump out the cell, the wavelength increases until, at some point, the cell is only 9-1/2 wavelengths long. Since the laser beam passes twice through the cell, the light now goes through one less oscillation within the cell. This has the same effect on the interference pattern as when the movable mirror is moved toward the beam-splitter by 1/2 wavelength. A single fringe transition will have occurred.

Originally there are  $N_i = 2d/\lambda_i$  wavelengths of light within the cell (counting both passes of the laser beam). At the final pressure there are  $N_f = 2d/\lambda_f$  wavelengths within the cell. The difference between these values,  $N_i - N_f$ , is just  $N$ , the number of fringes you counted as you evacuated the cell. Therefore:  $N = 2d/\lambda_i - 2d/\lambda_f$ .

However,  $\lambda_i = \lambda_0/n_i$  and  $\lambda_f = \lambda_0/n_f$ ; where  $n_i$  and  $n_f$  are the initial and final values for the index of refraction of the air inside the cell. Therefore  $N = 2d(n_i - n_f)/\lambda_0$ ; so that  $n_i - n_f = N\lambda_0/2d$ . The slope of the  $n$  vs pressure graph is therefore:

$$\frac{n_i - n_f}{P_i - P_f} = \frac{N\lambda_0}{2d(P_i - P_f)}$$

where  $P_i$  = the initial air pressure;  $P_f$  = the final air pressure;  $n_i$  = the index of refraction of air at pressure  $P_i$ ;  $n_f$  = the index of refraction of air at pressure  $P_f$ ;  $N$  = the number of fringe transitions counted during evacuation;  $\lambda_0$  = the wavelength of the laser light in vacuum (see your instructor);  $d$  = the length of the vacuum cell (3.0 cm).

1. Calculate the slope of the  $n$  vs pressure graph for air.
2. On a separate piece of paper, draw the  $n$  vs pressure graph.

## Questions

1. From your graph, what is  $n_{\text{atm}}$ , the index of refraction for air at a pressure of 1 atmosphere (76 cm Hg).
2. In this experiment, a linear relationship between pressure and index of refraction was assumed. How might you test that assumption?
3. The index of refraction for a gas depends on temperature as well as pressure. Describe an experiment that would determine the temperature dependence of the index of refraction for air.

## Experiment 3: The Index of Refraction of Glass

### EQUIPMENT NEEDED:

- Basic Interferometer (OS-9255A)
- Laser (OS-9171)
- Laser Alignment Bench (OS-9172)
- Interferometer Accessories  
Rotating Table, Glass Plate

### Introduction

In Experiment 2, the index of refraction of air was measured by slowly varying the density of air along a fixed length of one beam path in the Michelson Interferometer. That method obviously won't work with a solid substance, such as glass. Therefore, in order to measure the index of refraction of glass, it's necessary to slowly vary the length of glass through which the interferometer beam passes. This experiment introduces a technique for making such a measurement.

### Procedure

1. Align the laser and interferometer in the Michelson mode. See *Setup and Operation*.
2. Place the rotating table between the beam-splitter and movable mirror, perpendicular to the optical path.

► **NOTE:** if the movable mirror is too far forward, the rotating table won't fit. You may need to loosen the thumbscrew and slide the mirror farther back.

3. Mount the glass plate on the magnetic backing of the rotational pointer.
4. Position the pointer so that its "0" edge on the Vernier scale is lined up with the zero on the degree scale on the interferometer base.
5. Remove the lens from in front of the laser. Hold the viewing screen between the glass plate and the movable mirror. If there is one bright dot and some secondary dots on the viewing screen, adjust the angle of the rotating table until there is one bright dot. Then realign the pointer scale. The plate should now be perpendicular to the optical path.
6. Replace the viewing screen and the lens and make any minor adjustments that are necessary to get a clear set of fringes on the viewing screen.
7. Slowly rotate the table by moving the lever arm. Count the number of fringe transitions that occur as you rotate the table from 0 degrees to an angle  $\theta$  (at least 10 degrees).

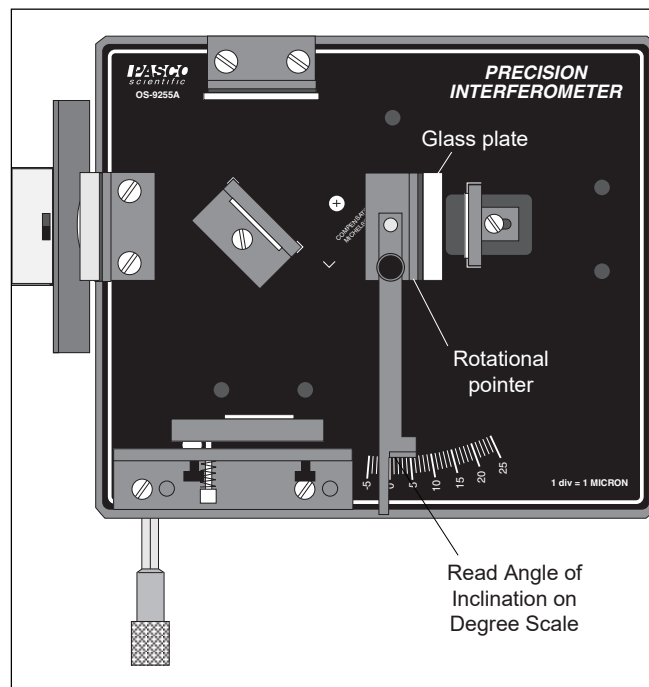

Figure 3.1. Equipment Setup

## Data Analysis

In principle, the method for calculating the index of refraction is relatively simple. The light passes through a greater length of glass as the plate is rotated. The general steps for measuring the index of refraction in such a case is as follows:

1. Determine the change in the path length of the light beam as the glass plate is rotated. Determine how much of the change in path length is through glass,  $d_g(\theta)$ , and how much is through air,  $d_a(\theta)$ .
2. Relate the change in path length to your measured fringe transitions with the following equation:

$$\frac{2n_a d_a(\theta) + 2n_g d_g(\theta)}{\lambda_0}$$

where  $n_a$  = the index of refraction of air (see Experiment 2),  $n_g$  = the index of refraction of the glass plate (as yet unknown),  $\lambda_0$  = the wavelength of your light source in vacuum, and  $N$  = the number of fringe transitions that you counted.

Carrying out this analysis for the glass plate is rather complicated, so we'll leave you with the equation shown below for calculating the index of refraction based on your measurements. Nevertheless, we encourage you to attempt the analysis for yourself. It will greatly increase your understanding of the measurement and also of the complications inherent in the analysis.

$$\frac{(2t - N\lambda_0)(1 - \cos\theta)}{2t(1 - \cos\theta) - N\lambda_0}$$

where  $t$  = the thickness of the glass plate.

► **NOTE:** Our thanks to Prof. Ernest Henninger, DePauw University, for providing this equation from *Light Principles and Measurements*, by Monk, McGraw-Hill, 1937.

## Suggestions for Additional Experiments

### Twyman-Green—

Twyman-Green operation gives students a quick, qualitative look at how interferometry can be used to test optical components. See *Twyman-Green Mode* in the *Setup and Operation* section of the manual.

Any distortion of the circular fringe pattern is due to spherical aberration from the test lens. Turn the lens until it sits at various angles to the optical path and watch the fringe pattern change. Distortion here is due partially to astigmatism from the lens.

### Spectral Light Fringes—

Although interferometry is easiest with a laser light source, measurements can be made successfully using any monochromatic source of sufficient brightness. However, if a laser is not used, it is generally not possible to project the interference fringes onto a screen. Instead, the fringes are viewed by looking into the beam-splitter (or into the movable mirror in Fabry-Perot mode).

If you use a spectral light source with spectral lines at several different frequencies, it may be necessary to use a filter that blocks all but one of the spectral wavelengths.

### Michelson Mode:

#### ► NOTE:

One difficulty when using a non-laser light source in Michelson mode is that the coherence length of the light is far less with a non-laser source. Because of this, the compensator should be used. It mounts magnetically on the back of the beam-splitter (the side opposite the thumbscrew).

It's also important that the optical paths of the two interfering beams should be nearly equal. To ensure that this is the case, set up the interferometer with a laser (if you have one) and adjust the movable mirror position until the fewest possible fringes appear on the screen. (Theoretically, when the beam paths are exactly equal, one big maximum should appear that occupies the whole screen. But this is usually not possible to achieve in practice due to optical imperfections.) Then remove the viewing screen and replace the laser with the spectral light source. If fringes aren't visible when looking into the beam-splitter, proceed as follows:

- a. Tape two thin pieces of wire or thread to the surface of the diffuser to form cross-hairs.
- b. Place the diffuser between the light source and the beam-splitter.
- c. Adjust the angle of the beam-splitter so that, when looking into the beam-splitter, you can see two images of the cross-hairs.
- d. Adjust the tilt of the fixed mirror until the cross-hairs are superimposed. You should be able to see the fringe pattern.

### Fabry-Perot mode:

- a. Tape two thin pieces of wire or thread to the surface of the diffuser to form cross-hairs.
- b. Set up the equipment in Fabry-Perot mode, and place the diffuser between the light source and the fixed mirror.
- c. Look into the movable mirror from behind. Adjust the tilt of the fixed mirror until the cross-hairs are superimposed. You should be able to see the fringe pattern.

### White Light Fringes—

With careful alignment, the interferometer will produce fringes from multi-chromatic or even white light. The procedure is the same as for any non-laser source, as described above. However, since it is harder to get a visible interference pattern, it is strongly recommended that you first set up the interferometer using a laser. Then substitute your white light source.

### Use a Photometer—

Use a photometer, such as PASCO Model OS-9152B, to scan the fringe patterns. You can compare the intensity distributions in the Michelson and Fabry-Perot modes. Or use it to more accurately determine polarization effects. Or just use it as an aid in counting fringes.

### Heat Distribution in Air—

With the interferometer in Michelson mode, strike a match and bring it close to one of the optical paths. Note the distortions in the fringe pattern. For a more quantitative approach, you could construct an air tight cell, and heat the contents to observe the effects of heat on the index of refraction of air.

► **IMPORTANT**— The Vacuum Cell is not designed to be heated.

### Index of Refraction for Gases—

Measure the indices of refraction for various gases.

Caution: The PASCO Vacuum Chamber is NOT designed to hold positive pressures. You will need to provide your own gas chamber.

### Fabry-Perot Spectroscopy—

The Fabry-Perot mode is customarily used as a high-resolution spectrometer. Very close spectral lines, as in magnetic splitting, can be resolved much more accurately than with any but the highest quality diffraction gratings.

## Maintenance

### Micrometer Calibration

The micrometer is calibrated before it is shipped. However, if recalibration becomes necessary, use the following procedure:

1. Turn the interferometer over, and remove the bottom cover.
2. Loosen the two screws shown in Figure A1. Slide the bearing surface toward the pivot to increase mirror movement per turn of the micrometer dial. Slide the bearing surface away from the pivot to decrease mirror movement per dial turn. Tighten the screws and replace the bottom cover.

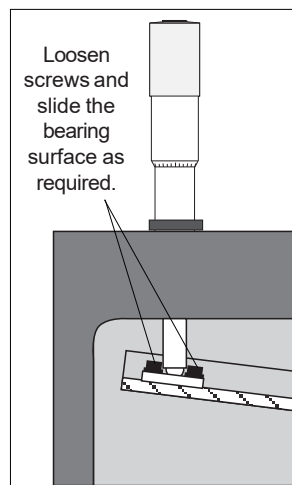

**Figure A1.**  
Calibration

Testing your calibration is most easily performed using a laser light source of known wavelength, as in Experiment 1.

### Micrometer Spacer Replacement

In order to provide extremely fine, backlash-free control of the movable mirror, the mechanical linkage between the micrometer and the movable mirror is maintained under a state of spring-loaded compression. This compression also holds part of the linkage (a spacer) in place. Under normal use, the spacer will never fall out of position. However, a sudden jolt can jar the spacer and the spring loose. In this case, the micrometer will no longer work, and you'll hear the parts rolling around inside.

### To replace the spacer:

1. Turn the interferometer over, and remove the bottom cover.
2. Position the spacer between the two ball bearings, as shown in Figure A2. Release the lever, and check that the spacer is snugly in place.
3. Replace the bottom panel.

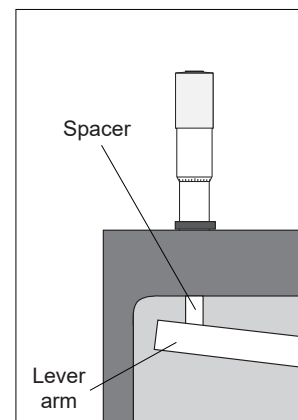

**Figure A2.** Spacer Replacement

### Mirror Care

The mirror and beam-splitter surfaces are precision ground and coated. Dirt or scratches will distort the fringe pattern, so handle all optical surfaces with care. Clean the surfaces occasionally with lens tissue.

### Vacuum Cell

Clean the glass windows on the vacuum chamber occasionally with lens tissue.

### Storage

Rotate the Micrometer Knob fully IN before storing the Interferometer.

## Replacement Parts

<b>Component</b>	<b>Part No.</b>	<b>Component</b>	<b>Part No.</b>
Interferometer Base	003-05137	Vacuum Cell	003-05162
Adjustable Mirror	003-03957	Rotational Pointer	003-05160
Beam-Splitter	003-03956	Fitted Case	650-05178
Movable Mirror	003-03955	Viewing Screen	003-05119
Component Holder	003-05161	Diffuser	003-03941
Compensator	003-03958	Polarizer	003-04924
Interferometer Manual	012-05187	Glass Plate	003-04034
Vacuum Pump	OS-8502	Lens, 18mm FL	003-03814
		Lens, 48mm FL	003-03806

# Teacher's Guide

## Experiment 1: Introduction to Interferometry

### Part I – General

	Dm	wavelength
Michelson	$1.60 \times 10^{-5}$	$640.0 \times 10^{-9}$
	$1.60 \times 10^{-5}$	$640.0 \times 10^{-9}$
	$1.60 \times 10^{-5}$	$640.0 \times 10^{-9}$
Fabry-Perot	$1.60 \times 10^{-5}$	$640.0 \times 10^{-9}$
	$1.50 \times 10^{-5}$	$600.0 \times 10^{-9}$
	$1.55 \times 10^{-5}$	$620.0 \times 10^{-9}$
	average:	$630.0 \times 10^{-9} \pm 16.7 \times 10^{-9}$
	actual:	$632.8 \times 10^{-9}$
	% diff.	0.44%

### Part II – General

- The pattern became somewhat dimmer, due to absorption by the polarizer; but other than that, there was no variation when we polarized the light coming into the interferometer.
- Adding a polarizer in front of the movable mirror had little effect. The contrast of the interference pattern reduced, and the pattern rotated when the polarizer was rotated.
- There was no pattern unless the two polarizers were in the same orientation.

### Reference to – Analysis (Part II)

- The laser we used was unpolarized, and does not seem to change polarization with time.
- No, there was no change. This would support our hypothesis that the laser used was unpolarized.
- Cross-polarized beams do not interfere.

### Answers to – Questions

- The change in path length is twice the movement of the mirror.
- Measuring only many fringes, many times, decreases the chance of random error affecting our results.
- They were roughly the same. The Fabry-Perot measurement could instill more confidence, because the fringes are sharper and easier to count.
- The difference is probably due to our uncertainty in measurement.
- Limiting factors are play in the system and uncertainty in our micrometer position.
- Losing count of fringes, and inexact positioning of the fringes relative to our reference mark.
- In order to interfere, the two light beams must have the same polarization.

## Experiment 2: The Index of Refraction of Air

### Reference to – Procedure

1. The chamber will be properly aligned when the reflections off the front and back end-plates are aligned with each other and with the main interference pattern. (This alignment may actually cause a secondary interference pattern, but it will be very faint and will not affect your measurements.)
2. It seems easiest to apply the vacuum first, then count the fringes as the vacuum was released.

The average slope, starting at a gauge reading of 60, was  $3.462 \times 10^{-6}$ .

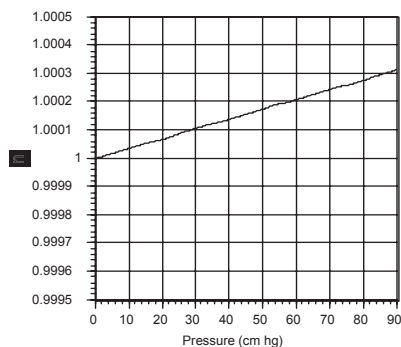

### Answers to – Questions

1. Extrapolating from our slope and the known index of refraction of vacuum,  

$$n_{\text{atm}} = 1.000263.$$
2. Measure the index of refraction at various pressures, and see if it increases linearly. (It does.)
3. Answers will vary; but they should include some way of heating the air on one arm of the interferometer without heating the air on the other arm or the interferometer itself.



## Experiment 3: The Index of Refraction of Glass

### Reference to – Procedure

1. The glass plate must be absolutely perpendicular to the laser for accurate measurement of the index of refraction. When the plate is perpendicular, there will be a faint secondary fringe pattern (Fabry-Perot interference between the front and back surfaces of the plate) visible in the center of the view screen.
2. It is important to measure as large an angle as possible, and measure the angle as carefully as possible.

### Reference to – Analysis

1. The actual equation, which is derived in *Optics of the Electromagnetic Spectrum*, by C.L. Andrews (Prentice-Hall, 1960) is

$$n_g = \frac{(2t - N\lambda_0)(1 - \cos\theta) + \left(\frac{N^2\lambda_0^2}{4t}\right)}{2t(1 - \cos\theta) - N\lambda_0}$$

The second term is negligible for visible wavelengths, and may be ignored.

### Notes – General

It is often difficult to count large numbers of fringes due to eyestrain. If you find this to be the case, you may want to make a circuit such as this:

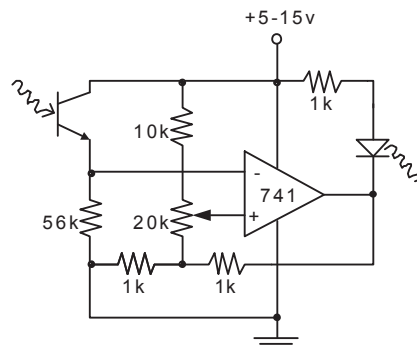

The phototransistor should be mounted in a plate of sheet steel, which can then be held in the magnetic viewscreen holder. Mask the transistor with a piece of electrical tape with a pinhole at the center. Adjust the sensitivity of the circuit with the 20k potentiometer so that the flashes of the LED can be counted instead of the actual fringes.

This circuit may also be used in conjunction with the PASCO Series 6500 computer interface so that the fringes can be counted by computer, if desired.

# Technical Support

## Feedback

If you have any comments about the product or manual, please let us know. If you have any suggestions on alternate experiments or find a problem in the manual, please tell us. PASCO appreciates any customer feedback. Your input helps us evaluate and improve our product.

## To Reach PASCO

For technical support, call us at 1-800-772-8700 (toll-free within the U.S.) or (916) 786-3800.

fax: (916) 786-3292

e-mail: [techsupp@pasco.com](mailto:techsupp@pasco.com)

web: [www.pasco.com](http://www.pasco.com)

## Contacting Technical Support

Before you call the PASCO Technical Support staff, it would be helpful to prepare the following information:

- ▶ If your problem is with the PASCO apparatus, note:
  - Title and model number (usually listed on the label);
  - Approximate age of apparatus;
  - A detailed description of the problem/sequence of events (in case you can't call PASCO right away, you won't lose valuable data);
  - If possible, have the apparatus within reach when calling to facilitate description of individual parts.
- ▶ If your problem relates to the instruction manual, note:
  - Part number and revision (listed by month and year on the front cover);
  - Have the manual at hand to discuss your questions.

