

Drop Counter

PS-2117

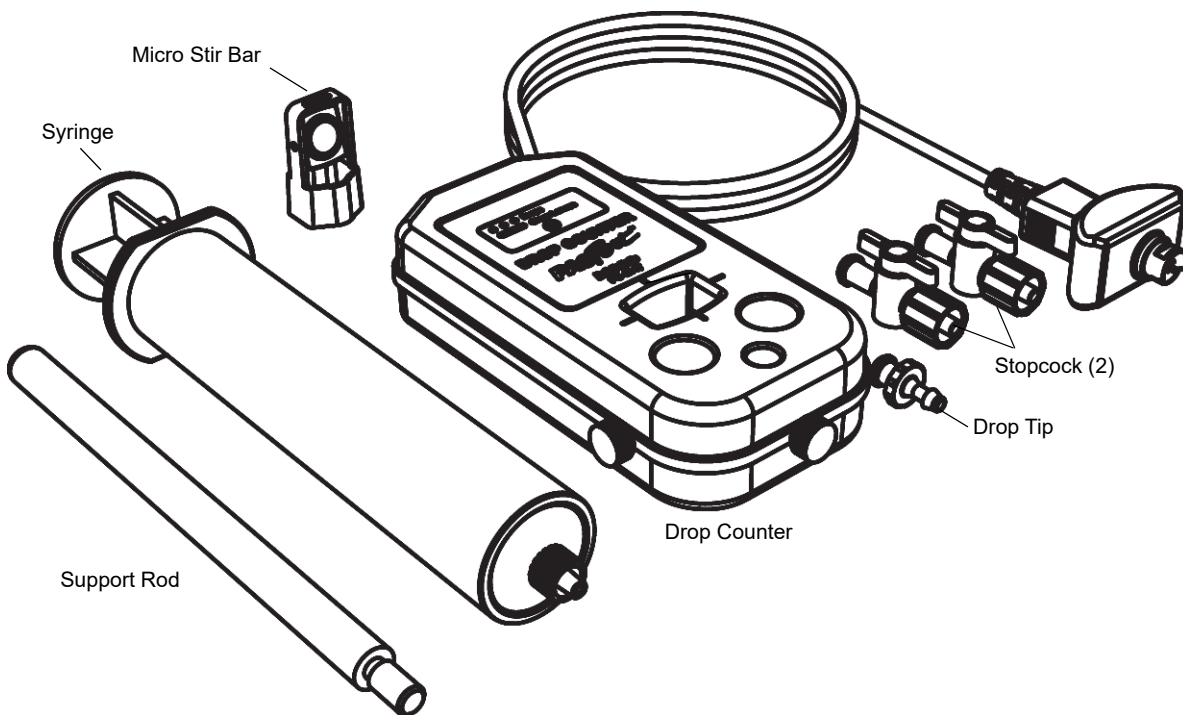

Included Items	Included Items
Drop Counter	Stopcock (2)
Micro Stir Bar	Drop Tip
Syringe (60 mL)	Support Rod

Other Needed Items*
Three-finger Clamp (SE-9445)
Support Rod and Stand (SE-9451)
Multi Clamp (ME-9507)
Magnetic Stir Plate (SE-7770)
Beaker, 150 mL
Graduated Cylinder, 10 mL

Required Items	Required Items
PASCO Interface*	Data Acquisition Software*

*See the PASCO catalog or the PASCO web site at www.pasco.com for more information

Recommended	Recommended
pH Sensor*	Temperature Sensor*

Consumables	Consumables
0.1 M NaOH	0.005 M HCl

Quick Start

1. Connect the Drop Counter to your PASPORT compatible PASCO interface.
2. If you are using a computer, connect the interface to it and start the data acquisition software.
3. Touch, press, or click to begin recording data.
4. Allow drops of liquid to fall through the rectangular opening.

Introduction

The Drop Counter measures the number of drops of fluid that fall through the rectangular opening of the sensor. It is typically used in conjunction with a pH sensor and other equipment to perform a titration. Data from the Drop Counter and other sensors are recorded and displayed in software such as SPARKvue, PASCO Capstone, or on a datalogging interface such as the SPARK SLS or Xplorer GLX.

The Drop Counter can be mounted on a support rod and the support rod can be clamped to a rod stand. The counter is equipped with three integrated probe holders. The included Micro Stir Bar fits onto the end of a pH probe or probe of the same diameter.

Assembling the Drop Dispenser

1. Remove the plunger from the syringe.
2. Connect the two stopcocks together and set the valves at right angles. Connect the stopcocks to the end of the syringe.
3. Connect the drop tip to the bottom of the stopcocks.

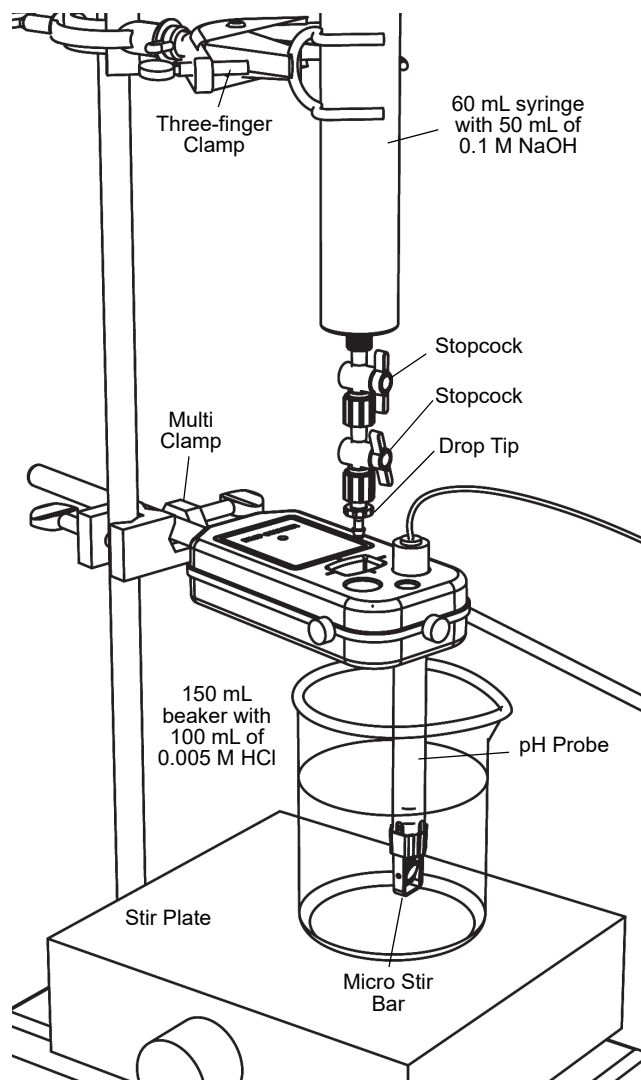

Calibrating the Drop Counter

The Drop Dispenser has two stopcocks. The top stop cock is used to regulate flow rate and the bottom stopcock is used to turn the flow on and off. The bottom stopcock should either be in the completely open or completely closed position.

The following two methods illustrate the calibration procedure.

Calibration (Generic Process)

1. Attach the Drop Dispenser (syringe, two stopcocks and drop tip) to a support rod.
2. Fill the syringe with titrant.
3. Open both stopcock valves and adjust the valve on the top stopcock so that the drops fall at a rate of about 1 drop per second. Close the bottom valve after the rate is achieved.
4. Connect the Drop Counter to a PASPORT interface.
5. Align the drop tip with the opening in the Drop Counter. Put a graduated 10 mL cylinder under the Drop Counter opening.
6. Open the bottom stopcock valve and monitor the number of drops.
7. After about 10 mL of titrant is collected in the graduated cylinder, close the bottom stopcock.
8. Open the calibration screen in the data acquisition software and input the number of drops and the volume.

Calibration Using SPARKvue or SPARK SLS

The drop counter is calibrated, using the SPARK SLS or SPARKvue Tools to correlate the number of drops counted to the volume of liquid dispensed from the Drop Dispenser.

1. Attach the Drop Dispenser (syringe, two stopcocks and drop tip) to a support rod.
2. Fill the syringe with titrant.
3. Open both stopcock valves and adjust the valve on the top stopcock so that the drops fall at a rate of about 1 drop per second. Close the bottom valve after the rate is achieved.
4. Connect the Drop Counter and launch SPARK SLS or SPARKvue.
5. Align the drop tip with the opening in the Drop Counter. Put a graduated 10 mL cylinder under the Drop Counter opening.

- While on the Home screen, open the bottom stopcock to allow titrant to flow.
- After about 10 mL of titrant is collected in the graduated cylinder, close the bottom stopcock.
- Record the exact volume from the graduated cylinder.
- Build the desired display for your experiment.
- Select the **Experiment Tools** button.



Result: The Experiment Tools screen opens.

- Select **Calibrate Sensor**.

Result: The Calibrate Sensor: Select Measurement screen opens.

- Select the **Sensor:** box and select **Drop Counter**.
- Select the **Measurement:** box and select **Fluid Volume (ml)**.
- Select the **Calibration Type:** box and select **1 point (Adjust Slope Only)**.
- Select **NEXT**.

Result: The Calibrate Sensor screen opens

- Under Calibration Point 2 select the **Standard Value:** box and enter the recorded volume (from step 8).
- Under Calibration Point 2 select **Read From Sensor**.
- Select **OK** to exit the Calibrate Sensor screen.
- Select **OK** to exit the Experiment Tools screen.

Acid-Base Titration (Calibration Method)

Procedure

- Setup the equipment and consumables as shown.
- Connect the Drop Counter and pH Sensor to the PASPORT-compatible interface.
- Start the data acquisition software.
- Use the software to create a graph of pH vs. Fluid Volume.
- Start the stir plate.

- Touch, press, or click to begin recording data.
- Open the valve on the bottom stopcock so the titrant drops fall at about 1 drop per second.
- Observe the data on the pH versus Fluid Volume graph. After the equivalence point is reached, continue collecting data until the pH curve flattens.

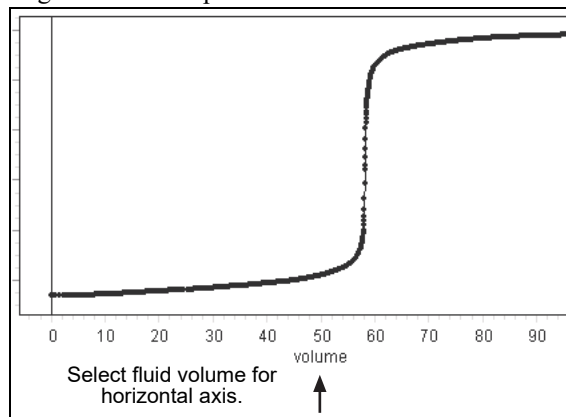

- Close the stopcock valve and stop data recording.

Acid-Base Titration (Alternative Method)

Procedure

- Set up the equipment and consumables as illustrated. Attach both stopcocks to the syringe, and attach the drop tip to the bottom stopcock. Line up the drop tip with the rectangular opening in the Drop Counter.
- Start with the valves of the stopcocks turned parallel to the table top. Add the solutions to the syringe and beaker.
- Write down the initial volumes of both solutions (in the syringe and in the beaker), and the molarity of the titrant (in the syringe).
- Connect the Drop Counter and pH sensor to your PASPORT compatible PASCO interface (or interfaces).
- If you are using a computer, connect the interface to it and start the data acquisition software. Set up a graph display of pH versus Drop Count.
- Start the stir plate.
- Touch, press, or click to begin recording data.
- Open the top stopcock. Slowly adjust the bottom stopcock to start delivering titrant at about 2 drops per second.

- Observe the data appearing on the pH versus drop count graph. After the equivalence point is reached, continue collecting data until the pH curve flattens.

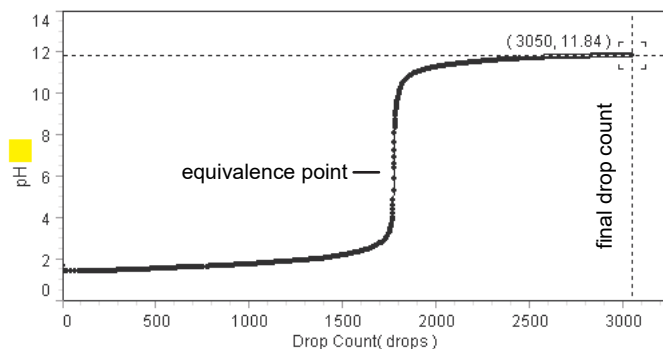

- Close the stopcocks.
- Stop data recording.
- Read the final volume of fluid in the syringe and calculate the net volume of titrant that was dispensed.
- Read the final drop count on the graph.
- In the calculator window of the software or datalogger, enter a calculation as shown below, but using your own values of total volume dispensed and final drop count. The calculation gives the volume of titrant dispensed over time based on the number of drops and the average volume per drop.

$$\text{volume} = [\text{Drop Count (drops)}] * 100/3050$$

In this example, “100” is the total volume dispensed (in mL) and “3050” is the final drop count.

- In the graph, change the horizontal axis to the calculated “volume”.

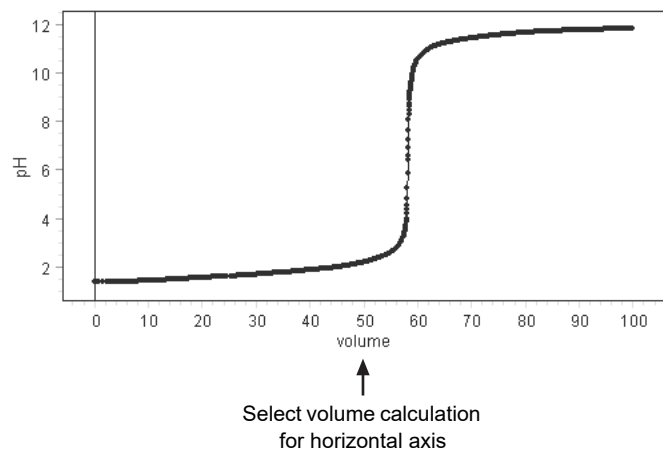

Tips

- Except for opening and closing the stopcocks, do not touch the syringe during the titration; otherwise, the drop size may change significantly.
- The drop rate must remain approximately constant (about 2 drops per second) in order for the drop size to remain constant.
- Drop size depends on the exact position of the bottom stopcock. Therefore, the average drop size will be different for every titration. For each titration, re-enter the volume used and drop count values in the calculation.

Other Titrations

Titrations with different solutions can be performed using the same equipment and procedure. Other probes (such as conductivity or ORP) can be used in place of the pH probe.

Theory of Operation

The Drop Counter uses an infrared light source and a photodetector. Lenses spread the light into a “sheet” and refocus it onto the photodetector. When a drop of fluid passes through the Drop Counter, it partially blocks this sheet of light, and the photodetector registers a momentary decrease in light intensity.

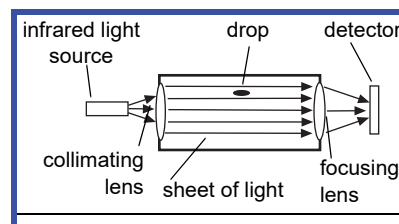

The Drop Counter uses infrared light and ignores visible light. On power up, it automatically adjusts the light level for the best sensitivity. Use the Drop Counter away from direct sunlight or other sources of infrared that may interfere with it.

Troubleshooting

Problem	Cause	Solution
Indicator light flashes twice for a single drop. Drop Counter registers more drops than actually dispensed.	Fluid is splashing back into the drop window.	Adjust the position of the beaker, Drop Counter, or syringe to eliminate splash back
Indicator LED remains on constantly. Drop Counter does not register drops.	Lenses in drop window are dirty or wet.	Clean lenses with water and dry with a cotton swab or tissue.

Specifications

Item	Value
Maximum Drop Count Rate:	40 drops per second
Minimum Object Detection Size	0.64 mm
Drop Window	18 mm by 13 mm
Detector Type	Infrared photodetector
Default Sample Rate	5 Hz
Maximum Sample Rate	10 Hz

Technical Support

For assistance with any PASCO product, contact PASCO at:

Address: PASCO scientific
10101 Foothills Blvd.
Roseville, CA 95747-7100

Phone: +1 916-462-8384 (worldwide)
800-772-8700 (U.S.)

E-mail: support@pasco.com

Web www.pasco.com/support

Limited Warranty For a description of the product warranty, see the PASCO catalog. **Copyright** The PASCO scientific *Instruction Sheet* is copyrighted with all rights reserved. Permission is granted to non-profit educational institutions for reproduction of any part of this manual, providing the reproductions are used only in their laboratories and classrooms, and are not sold for profit. Reproduction under any other circumstances, without the written consent of PASCO scientific, is prohibited. **Trademarks** PASCO, PASCO Capstone, PASPORT, and SPARKvue are trademarks or registered trademarks of PASCO scientific, in the United States and/or in other countries. For more information visit www.pasco.com/legal.

Product End of Life Disposal Instructions:

This electronic product is subject to disposal and recycling regulations that vary by country and region. It is your responsibility to recycle your electronic equipment per your local environmental laws and regulations to ensure that it will be recycled in a manner that protects human health and the environment. To find out where you can drop off your waste equipment for recycling, please contact your local waste recycle/disposal service, or the place where you purchased the product.

The European Union WEEE (Waste Electronic and Electrical Equipment) symbol (to the right) and on the product or its packaging indicates that this product must not be disposed of in a standard waste container.

