

Ethanol Sensor (PS-2194)

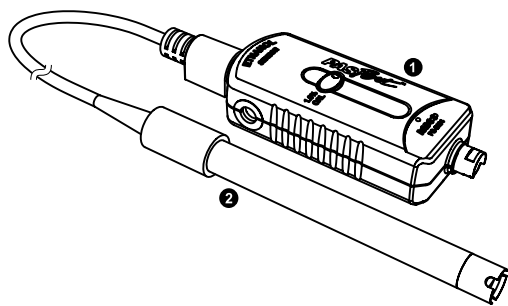

Included Parts

- 1 Amplifier
- 2 Probe
- 3 PTFE (Teflon Plumber's) tape for membrane replacement (not pictured)

Additional Parts Required

- PASPORT-compatible interface
- PASCO Data Collection Software

Replacement Parts

- See Technical Support

Quick Start

1. Connect the amplifier to your PASPORT-compatible interface.
2. Connect the probe to the amplifier.
3. If you are using a computer, connect the PASPORT interface to it and start the PASCO Data Collection Software.
4. Ensure that the membrane is installed and intact. There should be no tears or discoloration.
5. Place the end of the probe in the gas above a solution containing *less than 3% ethanol*.
6. Begin recording data in the software.

The probe stabilizes after about 10 minutes of warm-up time.

Introduction

The Ethanol Sensor measures the concentration of ethanol in a gas or indirectly in a liquid. The sensor's probe contains a material whose resistance decreases in the presence of ethanol. The sensor translates this resistance into an ethanol concentration measurement, which is recorded and displayed by the connected computer or datalogger. The Ethanol Sensor is well-suited for continuous recording and discrete measurements.

Precautions

- *Do not expose the probe to gas containing more than 3% ethanol, including the gas above alcoholic beverages.* Higher ethanol concentrations will deplete the sensing element. Note that the gas above a liquid contains about the same concentration of ethanol as the liquid itself.
- *Ensure that the teflon tape membrane is installed and intact before using the probe.* The membrane prevents the sensing element from getting wet. If the sensing element accidentally gets wet, wipe it gently with a soft cloth or lightly damp paper towel and dry it quickly. Note that the probe may be degraded or destroyed.
- *Do not immerse the probe.* The membrane (if it is in good condition) will protect the probe in case of accidental immersion. However, the probe is designed for use in gas only.

Connecting the Parts

1. Plug the amplifier's PASPORT connector into any port of a PASPORT-compatible interface.
2. Connect the probe to the amplifier.

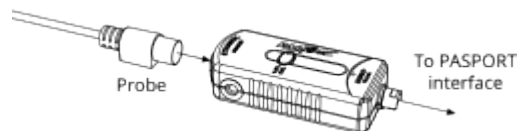

Figure 1. Connecting the probe and interface

3. If you are using a computer, connect the PASPORT-compatible interface to it and start the PASCO Data Collection Software.

Warm-up

The probe contains a heating element. After connecting the sensor to a powered PASPORT-compatible interface, wait about 10 minutes for the sensor's temperature to stabilize. Students should start the sensor before setting up the lab to ensure that its temperature has stabilized in time for data collection.

If the temperature of the gas surrounding the probe changes, the probe will need some time to stabilize again.

The sensitivity of the probe changes with temperature. Make measurements at a constant temperature after the probe temperature has stabilized.

Collecting Data

1. Ensure that the membrane is installed and intact. There should be no tears or discoloration.
2. Place the end of the probe just above a solution, or in a gas, containing *less than 3% ethanol*.
3. Start data recording.



NOTE: For more information on data collection using PASCO software, see the PASCO Capstone or SPARKvue online help.

Calibration

For accurate measurements, first calibrate the sensor. You will need a solution of 1% ethanol in water; to prepare this solution, pipette in 1.43 mL (or 1.24 g) of 70% ethanol in a 100 mL volumetric flask and fill to the line with water. The solution should be at the same temperature as the solutions to be measured.

Calibration data is stored in the sensor's memory and persists until the sensor is calibrated again, even if the sensor is unplugged from the interface.

1. Connect the sensor to an interface as described above.
2. Place the probe above the 1% ethanol solution.
3. Observe the ethanol concentration reading in the software.
4. Wait until the reading stabilizes.
5. Press and hold the **1% CAL** button on the sensor for 4 seconds.

Immediately after a successful calibration, the sensor's output will read 1%, and the button will be illuminated.

About the Membrane

A roll of membrane material is included with the sensor. The material is PTFE thread sealing tape, about 25 mm wide, typically used by plumbers. The membrane protects the sensing element from liquid, but is permeable to ethanol gas.

Membrane Replacement

Change the membrane when it is torn or discolored.

1. Pull the retaining ring off the end of the probe.
2. Remove and discard the old membrane.
3. Cut a 25 mm square of new membrane material.
4. Place the new membrane over the end of the probe.
5. Push the retaining ring onto the end of the probe over the new membrane.
6. *Optional:* Use a sharp knife to trim off excess membrane from around the retaining ring.

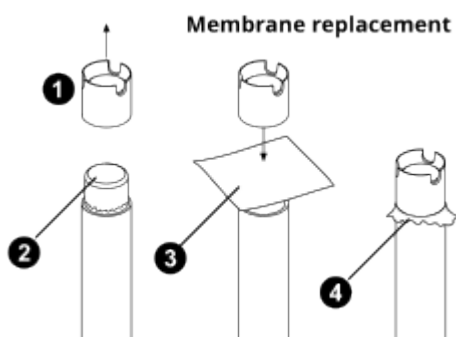

- 1 Retaining ring
- 2 Old membrane
- 3 New membrane
- 4 Excess membrane

Factors that Affect the Measurement

Temperature and humidity: The sensor's temperature is determined both by its internal heater and the temperature of its surroundings. Allow the probe time to reach a stable temperature after you plug it in, or after the temperature of its surroundings changes. Keep temperature and humidity constant during calibration and measurement.

Air flow: Air flow around or into the probe affects its temperature. Minimize air flow during calibration and measurement.

Interference molecules: In addition to ethanol gas, the sensor responds to hydrogen, isobutane, carbon monoxide, and methane.

Sensor Response versus Temperature

The graph below shows how changing temperature affects the sensor. The probe was placed in the gas above a 1% ethanol solution and calibrated. The temperature was then varied between 5° C and 45° C. Though the actual ethanol concentration of the solution remained constant, the sensor's reading deviated from 1% at temperatures above and below the calibration temperature. This data illustrates the importance of keeping the temperature constant during calibration and measurement.

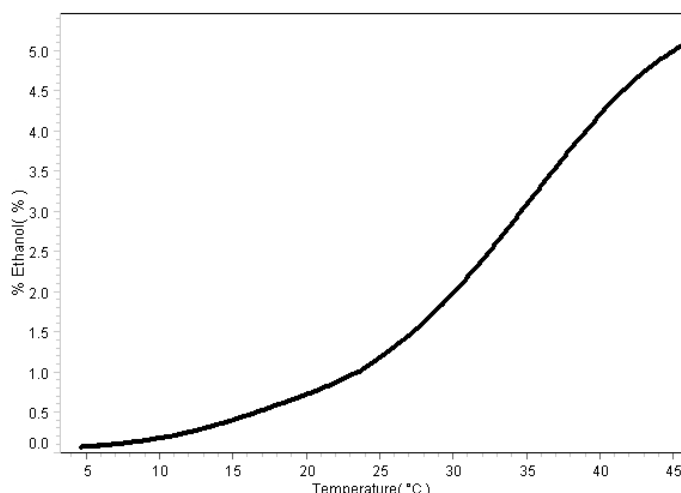



Figure 2. Sensor response vs. temperature; the actual ethanol concentration is constant

The relationship between temperature and sensor response varies from probe to probe. To create a similar plot for your specific probe, follow the steps below.

1. Place the probe and a temperature sensor just above a 1% ethanol solution. Keep the temperature sensor about 1 cm away from the heating element at the end of the ethanol probe. Seal the container to keep the gas in.
2. Calibrate the ethanol sensor at room temperature.
3. Place the container in a cold water bath. Wait for the temperature inside the container to equilibrate with the water bath.
4. Start data recording.
5. Use a hot plate to slowly increase the temperature of the water bath.

Software Help

See the SPARKvue Help or PASCO Capstone Help for information about collecting, displaying, and analyzing data.

- In SPARKvue, select the **HELP** button  in any screen, including the Home Screen.
- In PASCO Capstone, select **PASCO Capstone Help** from the **Help** Menu, or press **F1**.

Sample Experiment

1. Mix approximately half a teaspoon of baker's yeast and one teaspoon of a simple sugar (such as glucose or lactose) into 100 mL of lukewarm (about 42°C) water.
2. Place the end of the probe just above the liquid.
3. Start data recording.
4. Observe the reading for about 45 minutes as the ethanol concentration increases.

Repeat these steps at different temperatures, and with different amounts and types of sugar and yeast. Note how these factors affect the rate of ethanol formation.

Specifications and accessories

Visit the product page at [pasco.com/product/PS-2194](https://www.pasco.com/product/PS-2194) to view the specifications and explore accessories. You can also download experiment files and support documents from the product page.

Experiment files

Download one of several student-ready activities from the PASCO Experiment Library. Experiments include editable student handouts and teacher notes. Visit [pasco.com/freelabs/PS-2194](https://www.pasco.com/freelabs/PS-2194).

Technical Support

Need more help? Our knowledgeable and friendly Technical Support staff is ready to answer your questions or walk you through any issues.

-  Chat [pasco.com](https://www.pasco.com)
-  Phone 1-800-772-8700 x1004 (USA)
+1 916 462 8384 (outside USA)
-  Email support@pasco.com

Replacement Parts

Replacement parts may be available for this product. Contact Technical Support about replacement parts.

- Replacement probe (contact Tech Support)
- Additional PTFE tape (contact Tech Support)

For more information about the Ethanol Sensor, and the latest revision of this Instruction Sheet, visit the PASCO website at www.pasco.com/manuals and enter the product name or product number (PS-2194) in the Search text window.

Limited Warranty

For a description of the product warranty, see the Warranty and Returns page at www.pasco.com/legal.

Copyright

This document is copyrighted with all rights reserved. Permission is granted to non-profit educational institutions for reproduction of any part of this manual, providing the reproductions are used only in their laboratories and classrooms, and are not sold for profit. Reproduction under any other circumstances, without the written consent of PASCO scientific, is prohibited.

Trademarks

PASCO and PASCO scientific are trademarks or registered trademarks of PASCO scientific, in the United States and in other countries. All other brands, products, or service names are or may be trademarks or service marks of, and are used to identify, products or services of, their respective owners. For more information visit www.pasco.com/legal.

Product end-of-life disposal



This electronic product is subject to disposal and recycling regulations that vary by country and region.

It is your responsibility to recycle your electronic equipment per your local environmental laws and regulations to ensure that it will be recycled in a manner that protects human health and the environment.

To find out where you can drop off your waste equipment for recycling, please contact your local waste recycle or disposal service, or the place where you purchased the product.

The European Union WEEE (Waste Electronic and Electrical Equipment) symbol on the product or its packaging indicates that this product must not be disposed of in a standard waste container.

CE statement

This device has been tested and found to comply with the essential requirements and other relevant provisions of the applicable EU Directives.

FCC statement

This device complies with part 15 of the FCC Rules. Operation is subject to the following two conditions:

- (1) This device may not cause harmful interference, and (2) this device must accept any interference received, including interference that may cause undesired operation.