

Matter Model

Model No. ME-9825A

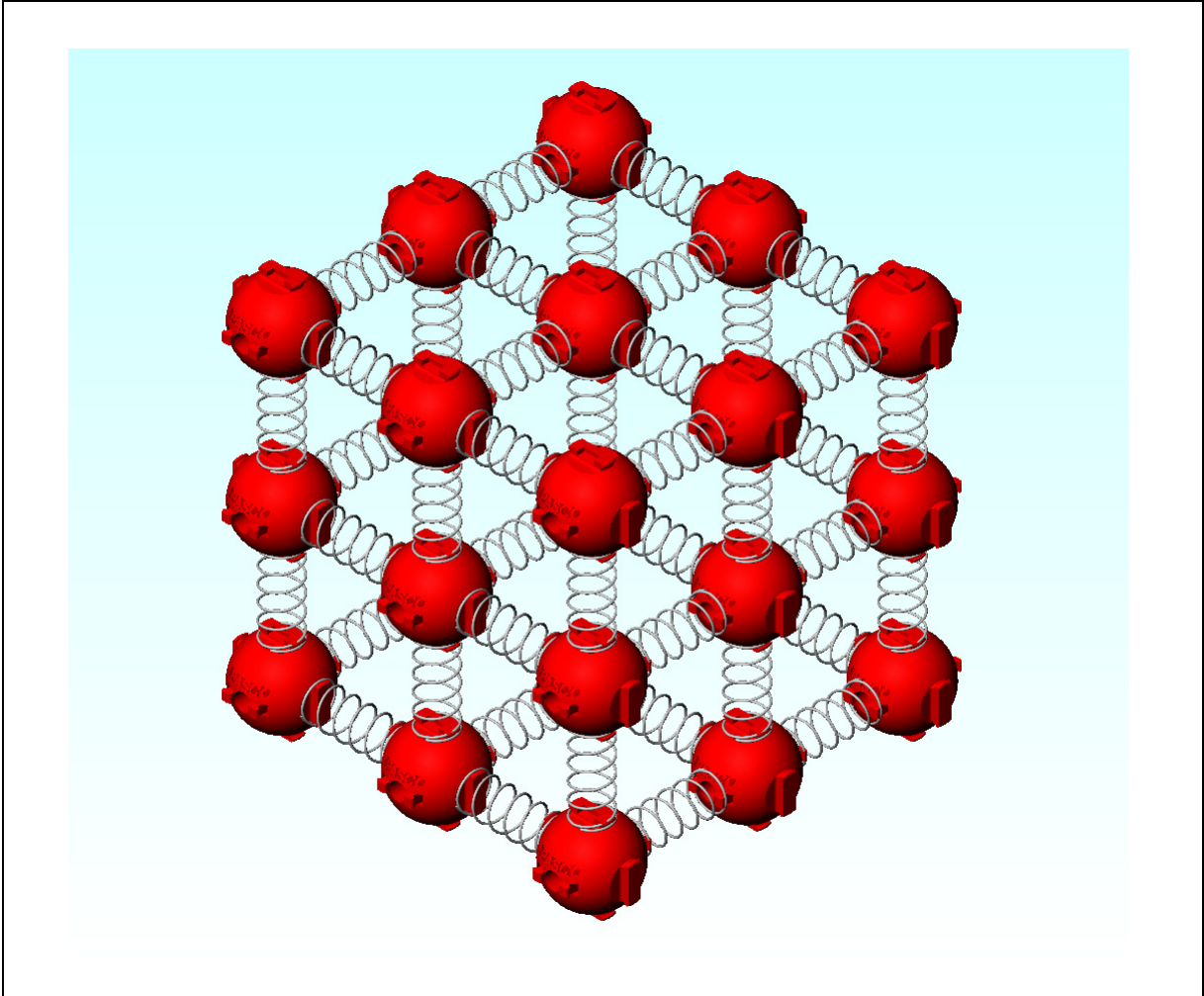

Equipment List

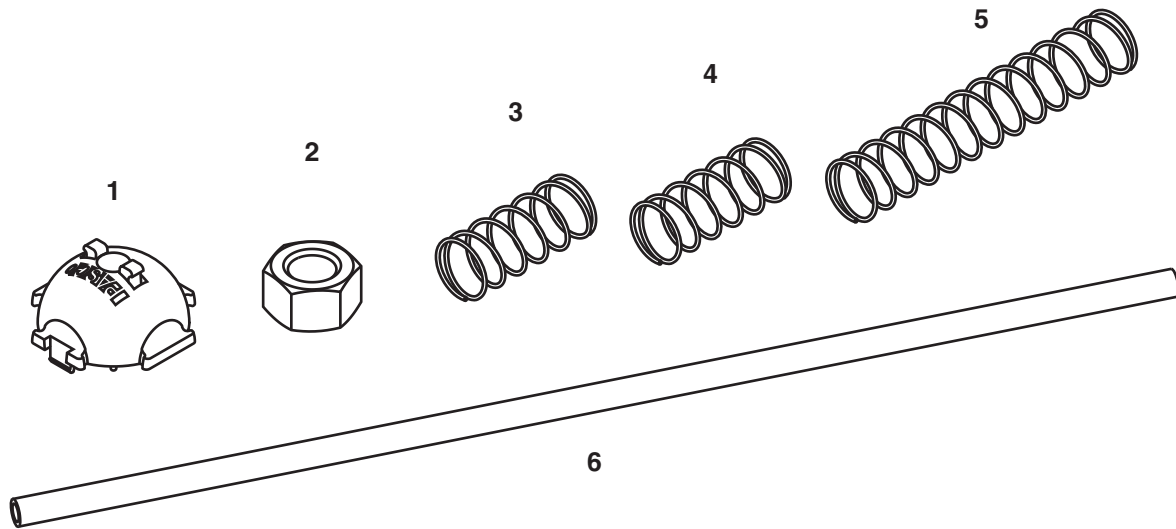

| Included Equipment | Quantity | Replacement Model Number |
|----------------------|----------|--------------------------|
| 1. Atom Half | 80 | 648-07820 |
| 2. Hex nut, 3/8 - 16 | 30 | 614-080 |
| 3. Heavy Spring | 60 | ME-9829 (set of 60) |
| 4. Light Spring | 60 | ME-9830 (set of 60) |
| 5. Long Spring | 60 | ME-9887 (set of 60) |
| 6. Tube | 1 | 648-07821 |

Introduction

The PASCO ME-9825A is comprised of many components which, when assembled and reassembled in a variety of configurations, can be used to model many demonstrations. Some suggested uses can be found in the Activities section of this manual.

Equipment Setup

Assembling Atom Halves

1. Position two atom halves as shown in Figure 1 and snap together.

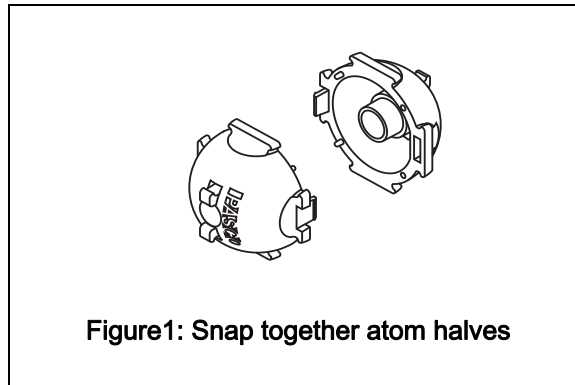

Building A Cubic Atom Model

1. Seat the single closed winding at either end of a spring inside a cleat feature of an assembled cubic atom model. See Figure 2

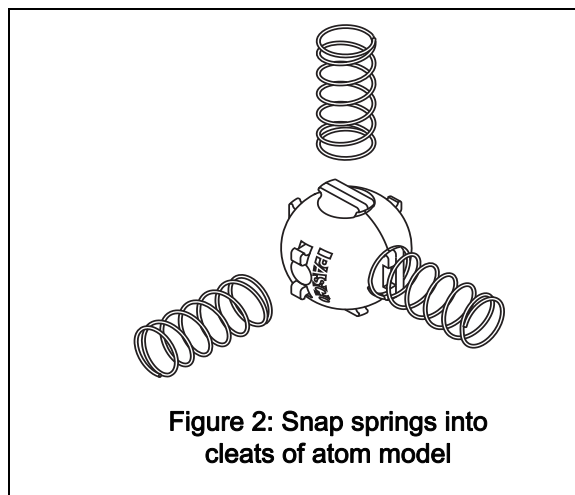

2. Create desired cubic atom model by alternately assembling atom models and springs.

Increasing the Mass of the Atom

1. Position one hex nut between two atom halves and snap together. See Figure 3.

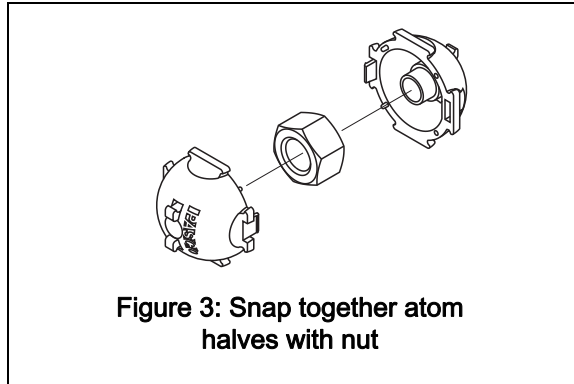

Assembling A Longitudinal Wave Model

1. Seat the single closed winding at either end of a spring inside a cleat feature of an assembled atom model (with nuts).
2. Create desired longitudinal wave model by alternately assembling atom models and springs onto tube as shown in Figure 4.

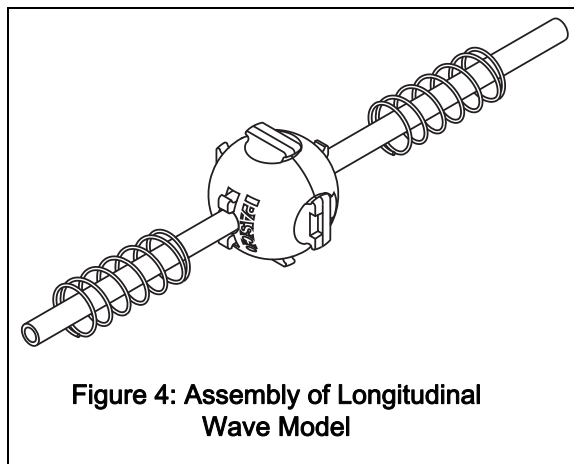

Assembling A Transverse Wave Model

1. Seat the single closed winding of a heavy spring inside a cleat feature of an assembled atom model. Be certain to attach springs along the seam of the atom to prevent splitting (fission) from occurring.

2. Create desired length transverse wave model by alternately assembling atom models and springs onto tube as shown in Figure 5.

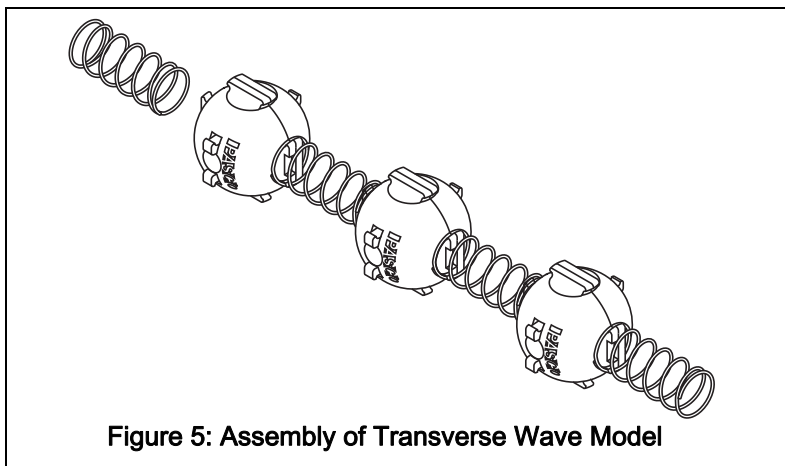

Activities

Mechanisms of Normal Forces

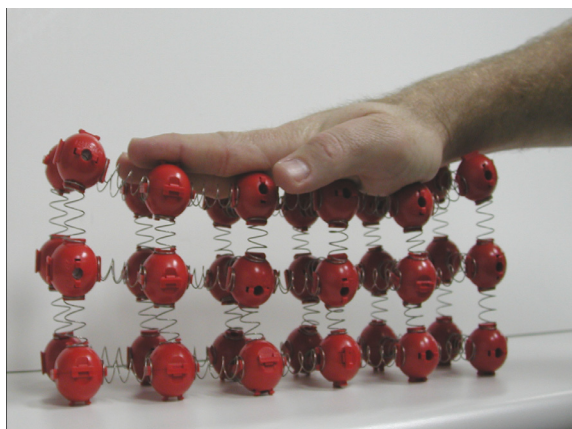

Figure 6: Demonstration of Normal Forces

Students often have difficulty believing that solid objects, such as a table, can exert forces. Instead, they believe that the table simply "gets in the way" of the object. By using the matter model with a heavy book, students can see the atoms compress when the book is placed on it. A 4 x 3 x 2 arrangement should be used for this activity, so the matter model is more stable when the book is placed on it.

Vibrations

The effects of vibrations can be seen quite vividly in the matter model. Any rectangular or cubic arrangement can be used. Strike the matter model with an impact force and observe the vibrational patterns.

Torque and Shear Forces

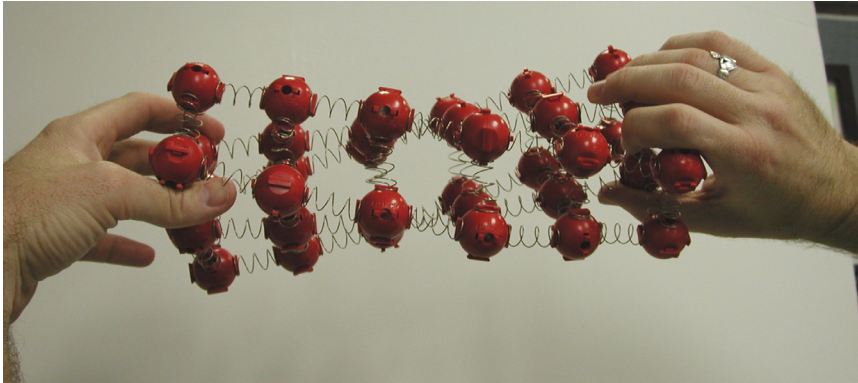

Figure 7: Demonstration of Torque Forces

The effects of torque and shearing forces can be demonstrated when the matter model is constructed in a $5 \times 3 \times 2$ configuration. In addition, when supported only on one side a cantilever can be modeled effectively.

Wave Patterns



Figure 8: Demonstration of a Transverse Wave



Figure 9: Demonstration of a Longitudinal Wave

By connecting many atoms (without nuts) in a linear arrangement with the heavy springs, students can easily generate standing wave patterns. The atoms should

be laid on a smooth tabletop or floor for this activity. The mass of each atom can be changed by inserting the included nuts.

Wave Speed and Density

Each of the atoms is designed to allow an included nut to be inserted. In this way, students can change the density of the wave medium and observe the relationship between wave speed and density. This effect can be investigated for both transverse and longitudinal waves. Use the configuration suggested in the previous activity for transverse waves. For a demonstration of longitudinal waves, use the included brass tube, which fits through the hole in each atom. It is more effective to use the light springs for a longitudinal wave activity, since the wave speeds will be lower.

Pressure



Figure 10: Demonstration of Pressure

With the atoms in a linear configuration and using the provided brass tube, turning the arrangement vertically is a nice demonstration of pressure. The lowest atoms must support the weight of all atoms above. This causes the lower springs to be more compressed, thus the atoms are closer together.

Technical Support

For assistance with any PASCO product, contact PASCO at:

Address: PASCO scientific
10101 Foothills Blvd.
Roseville, CA 95747-7100

Phone: 916-786-3800 (worldwide)
800-772-8700 (U.S)

Fax: (916) 786-3292

Web: www.pasco.com

Email: techsupp@pasco.com

Limited Warranty

For a description of the product warranty, see the PASCO catalog.

Copyright

The PASCO scientific 012-00000A *Matter Model Instruction Sheet* is copyrighted with all rights reserved. Permission is granted to non-profit educational institutions for reproduction of any part of this manual, providing the reproductions are used only in their laboratories and classrooms, and are not sold for profit. Reproduction under any other circumstances, without the written consent of PASCO scientific, is prohibited.

Trademarks

PASCO, PASCO scientific, DataStudio, PASPORT, and ScienceWorkshop are trademarks or registered trademarks of PASCO scientific, in the United States and/or in other countries. All other brands, products, or service names are or may be trademarks or service marks of, and are used to identify, products or services of, their respective owners. For more information visit www.pasco.com/legal.