

Includes
Teacher's Notes
and
Typical
Experiment Results



Instruction Manual and Experiment Guide for the PASCO scientific Model SE-9717

012-07190B

MAGDEBURG PLATES

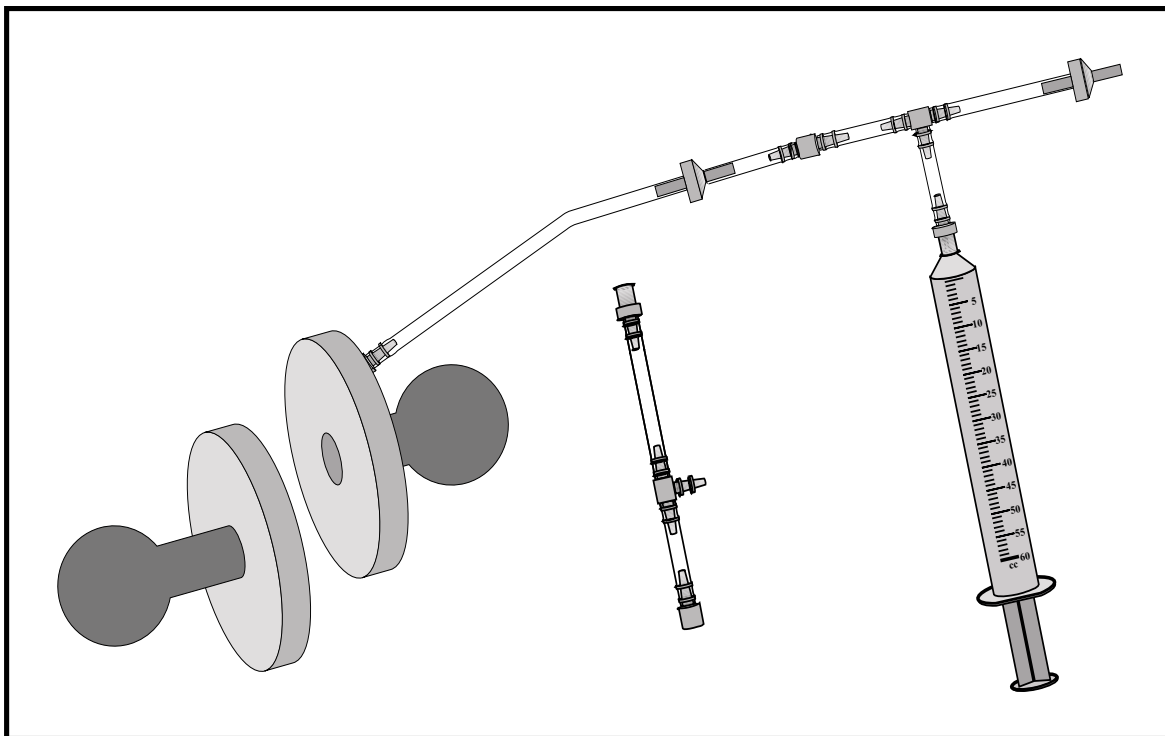

© 1999 PASCO scientific

PASCO[®]
scientific

10101 Foothills Blvd. • Roseville, CA 95747-7100
Phone (916) 786-3800 • FAX (916) 786-8905 • www.pasco.com

better

ways to

teach science



The exclamation point within an equilateral triangle is intended to alert the user of the presence of important operating and maintenance (servicing) instructions in the literature accompanying the device.

Table of Contents

Section	Page
Copyright, Warranty, and Equipment Return	ii
Introduction	1
Equipment	1
Theory	2
Basic Setup	3
Setup with <i>ScienceWorkshop</i> and a Pressure Sensor	4
Operation	4
Operation with <i>ScienceWorkshop</i>	5
Cautions (Safety).....	5
Maintenance	6
Activities	
Activity 1: Determining the total force on the plates due to atmospheric pressure	7
Activity 2: Experimentally determining the force holding the plates together	9
Activity 3: Measuring the vacuum and observing its rate of decay using <i>ScienceWorkshop</i>	10
Activity 4: Determining the effect of air pressure on boiling point of water	11
Activity 5: Investigating the effect of air pressure on the size of a balloon	13
Activity 6: Investigating the effect of air pressure on a suction cup	13
Teacher's Notes	14–16
Appendix	
Technical Support	Back Cover

Copyright, Warranty, and Equipment Return

Please—Feel free to duplicate this manual subject to the copyright restrictions below.

Copyright Notice

The PASCO scientific 012-07190A Magdeburg Plates manual is copyrighted and all rights reserved. However, permission is granted to non-profit educational institutions for reproduction of any part of the manual providing the reproductions are used only for their laboratories and are not sold for profit. Reproduction under any other circumstances, without the written consent of PASCO scientific, is prohibited.

Limited Warranty

PASCO scientific warrants the product to be free from defects in materials and workmanship for a period of one year from the date of shipment to the customer. PASCO will repair or replace at its option any part of the product which is deemed to be defective in material or workmanship. The warranty does not cover damage to the product caused by abuse or improper use. Determination of whether a product failure is the result of a manufacturing defect or improper use by the customer shall be made solely by PASCO scientific. Responsibility for the return of equipment for warranty repair belongs to the customer. Equipment must be properly packed to prevent damage and shipped postage or freight prepaid. (Damage caused by improper packing of the equipment for return shipment will not be covered by the warranty.) Shipping costs for returning the equipment after repair will be paid by PASCO scientific.

Credits

Author: Jim Housley
Editor: Sunny Bishop

Equipment Return

Should the product have to be returned to PASCO scientific for any reason, notify PASCO scientific by letter, phone, or fax BEFORE returning the product. Upon notification, the return authorization and shipping instructions will be promptly issued.

► **NOTE: NO EQUIPMENT WILL BE ACCEPTED FOR RETURN WITHOUT AN AUTHORIZATION FROM PASCO.**

When returning equipment for repair, the units must be packed properly. Carriers will not accept responsibility for damage caused by improper packing. To be certain the unit will not be damaged in shipment, observe the following rules:

- ① The packing carton must be strong enough for the item shipped.
- ② Make certain there are at least two inches of packing material between any point on the apparatus and the inside walls of the carton.
- ③ Make certain that the packing material cannot shift in the box or become compressed, allowing the instrument come in contact with the packing carton.

Address: PASCO scientific
10101 Foothills Blvd.
Roseville, CA 95747-7100

Phone: (916) 786-3800
FAX: (916) 786-3292
e-mail: techsupp@pasco.com
Web site: www.pasco.com

Introduction

The PASCO SE-9717 Magdeburg Plates can be used to illustrate the concept of atmospheric pressure. Their flat plate design permits the calculation of forces using simple algebraic mathematics. In contrast, the traditional Magdeburg hemispheres required calculus for the calculation of the forces involved.

The transparency of the plates allows students to visualize the small chamber that is defined by the O-ring.

The choice of smaller and larger chambers through the use of the small and large O-ring further illustrates the concept of the pressures involved in holding the plates together.

The syringe and one-way check valve system constitute an inexpensive vacuum pump.

An extra connector is provided to permit the plates to be connected to a PASCO Pressure Sensor, allowing the monitoring of the pressure inside the chamber.

Optional Accessories

The optional Magdeburg Accessories are used to illustrate the effect of air pressure on the boiling temperature, on the size of a balloon, and on the suctional ability of a suction cup.

Equipment

Included:

Part Label	Part Name
A	plate with hose connector
B	plate without hose connector
C	large diameter O-ring
D	small diameter O-ring
E	tubing with check valve
F	tubing with T and check valve
G	60 cc syringe
H	tubing for connection with a PASCO Pressure Sensor

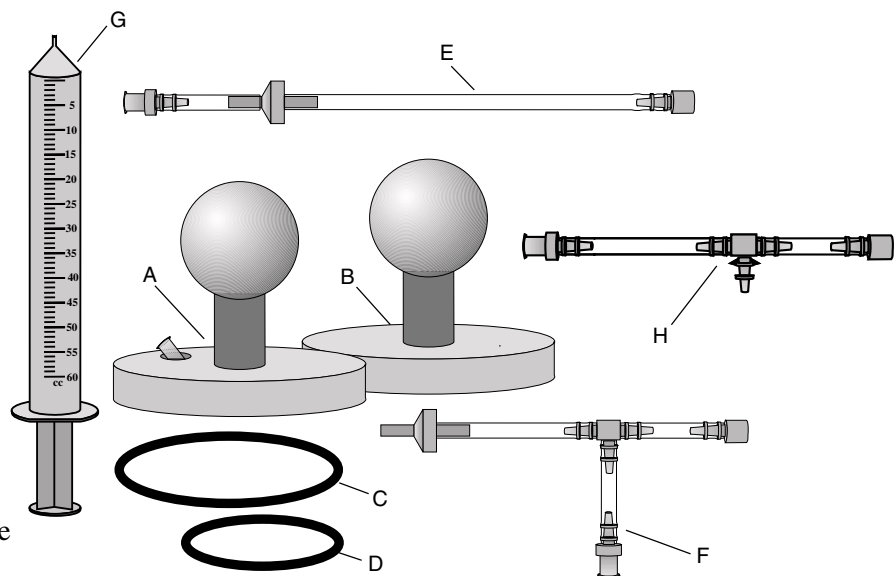

Note:

Parts E, F, and G constitute the vacuum pump

Additional Suggested:

- Magdeburg Plate Accessories (SE-9718)
- Pressure Sensor (CI-6532 or CI-6533)
[Do not use with CI-6534 Low Pressure or CI-6559 Humidity Sensor]
- ScienceWorkshop Interface (300, 500, 700, or 750)
- computer and data acquisition software
(ScienceWorkshop or DataStudio)

Theory

Before the vacuum is pulled, the pressure of the air inside the plates equals the pressure outside the plates (Figure 1a).

After the vacuum is pulled, the plates are held together with a force equal to the total pressure outside the plates minus the residual pressure inside the plates after the removal of air with the vacuum pump (Figure 1b).

Figure 1

(a) When no vacuum exists inside the plates, the force of atmospheric pressure against the outside of the plate equals the force pushing from the inside.

(b) When a vacuum has been created in the interior chamber, the force holding the plates together is equal to the atmospheric pressure

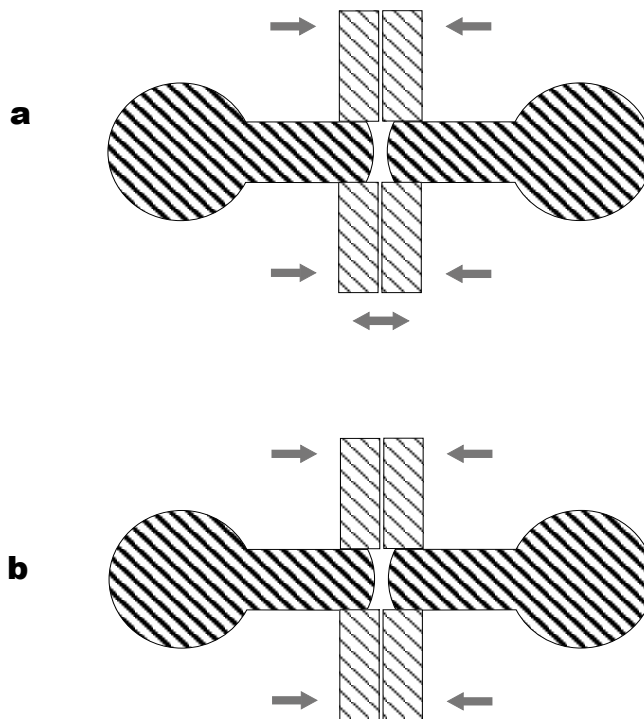

Note: Approximately 610 Newtons (137 pounds) of force are required to pull the plates apart when the large O-ring is used.

Basic Setup

1. Connect the hose connector on part E to the hose connector on part A (Figure 2).

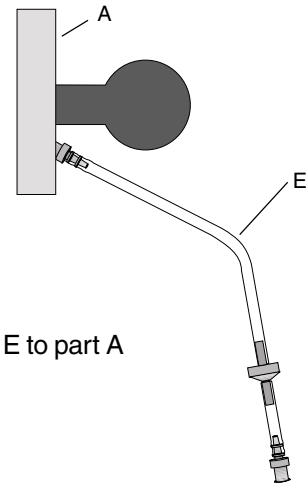

Figure 2
Connecting part E to part A

2. Connect part F to part E (Figure 3).
3. Connect the syringe to the T of part F.
4. Put O-ring on part A. (Use either one of the O-rings, but not both.)
5. Place part B (plate) on the O-ring on part A (other plate).

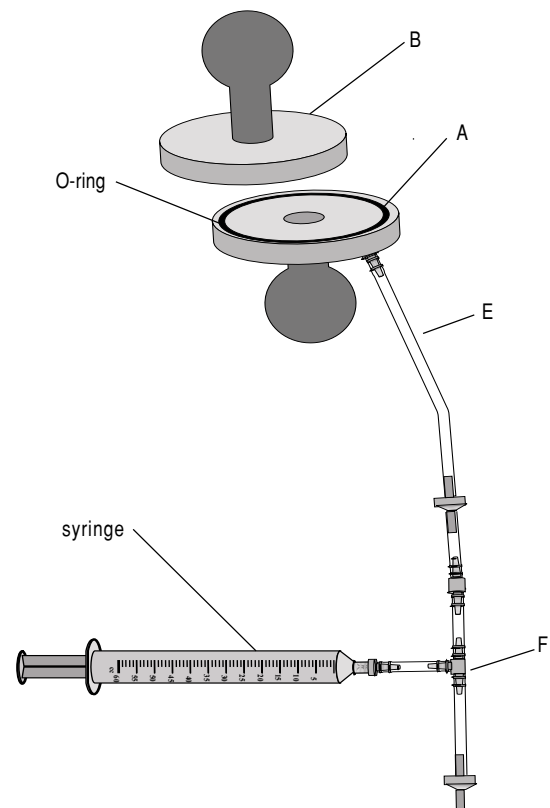

Figure 3
Completing the setup

Setup with Science- Workshop and a Pressure Sensor

1. Connect part H to the hose connector on part A (Figure 4).
2. Connect part E to part H.
3. Connect part F to part E.
4. Connect the syringe to the T of part F.
5. Connect the Pressure Sensor to the T on part H.
6. Put the O-ring on part A.
7. Place part B (plate) on the O-ring on part A (the other plate).

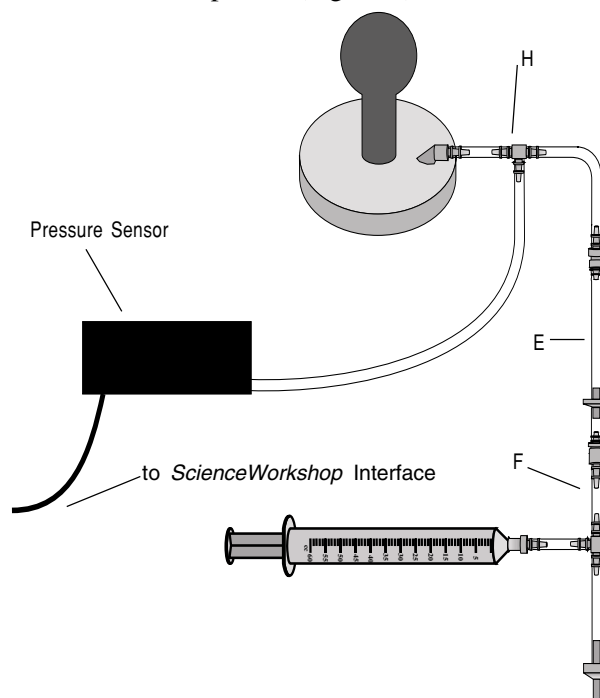

Figure 4
Connecting a Pressure Sensor to the vacuum line.

Operation without Science Workshop

To obtain qualitative information about the force required to offset atmospheric pressure, set up the Magdeburg Plates without *ScienceWorkshop*.

1. Pull vacuum (usually requires 3 or 4 pulls on the syringe plunger).
Note: The vacuum deteriorates slowly, usually over a 10 – 60 minute period.
2. Disconnect part F from part E. (Check valve in part E maintains the vacuum) (Figure 5).
3. Grasp both handles and pull (individual or “tug of war”).

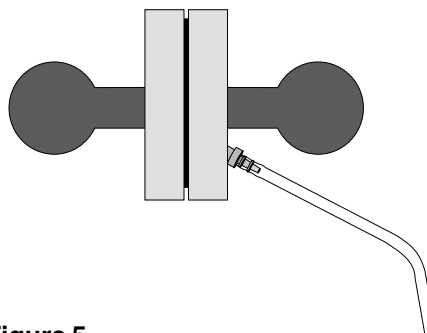

Figure 5
Magdeburg Plates ready for experimentation

Operation with Science Workshop

Operation with *ScienceWorkshop* to obtain quantitative information about the force required to offset atmospheric pressure, and to demonstrate the correlation between the breaking apart of the plates and the rise in interior pressure.

1. Set up to monitor the pressure while pulling the vacuum.
2. Pull vacuum (usually requires 3 or 4 pulls on the syringe plunger).

Note: The vacuum deteriorates slowly, usually over a 10 – 60 minute period.

3. Disconnect part E from part F (figure 6).
4. Start recording data.
5. Grasp both handles and pull (individual or “tug of war”).
6. Stop recording data.

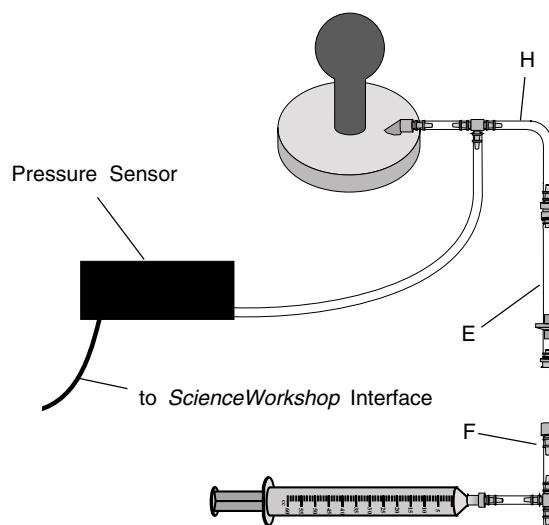

Figure 6
Magdeburg Plates ready for experimentation and monitoring of interior chamber pressure.

Note: Take care to avoid jerking the Pressure Sensor when the plates break apart.

Safety Considerations

This set is intended to be used by teachers, and their students while working under appropriate supervision.

- Make sure students are in a safe place to do a “tug of war.” Plates will separate suddenly, possibly throwing pullers off balance. There should be no breakable or sharp objects or sharp corners behind the students.
- Do not tie a weight onto one handle in an attempt to pull the plates apart.
- Do not tie ropes to the handles and do a “tug of war” to pull the plates apart. The plates will separate suddenly and will fly through the air at a very high velocity.

(continued on next page)

Safety Considerations (continued)

Generally...

Please teach and expect safe behavior in your classroom and lab. Safety considerations call for supervision of students at all times, use of safety eyewear, no horseplay, no unauthorized experimentation, immediate reporting to the instructor of accidents or breakage, among others.

More Specifically...

Any liquids entering the pump are apt to be discharged as a mist or spray. Only safe liquids such as water should be allowed to be used in association with the pump, and safety eyewear is definitely required.

Evacuate the chamber only using both plates. Attempting to evacuate the chamber while plate A is in contact with other surfaces could result in damage. Severe injury will result from evacuating the chamber while in contact with skin.

Do not use the apparatus if the plates have become cracked or otherwise damaged.

Maintenance

Plates and O-rings

The surfaces in the plates and the O-rings should be kept clean—free of dust.

- Use mild dishwashing soap and water to clean.
- Clean the groove with a cotton swab.



Cautions:

- Do not use abrasives.
- Do not use organic chemicals.
- Do not try to pry the plates open with a screw driver or similar apparatus.
- Do not apply plate A to any surface that might be damaged, particularly glass or skin.

Note: Vacuum grease should not be necessary on the O-rings or connectors, and use of it will attract dust and dirt.

Syringe

- Glycerin may be used on the plunger, but usually no lubricant is required.



Caution:

- Do not use any petroleum-based lubricant on the syringe. The plunger is very intolerant to petroleum-based substances.

Activity 1

Determining the total force on the plates is equal to the force of atmospheric pressure on the plates

Introduction

The total force on the plates is the total air pressure on the surface area defined by the O-ring. You will need to find the area inside the contact points of the O-ring. Then you can use the air pressure in your area (or use a typical value at sea level to find the approximate force). You will then use the relationship:

$$F_{\text{NET}} = (F_{\text{AP}} - F_{\text{R}}) * \pi r^2$$

Where

- F_{NET} = net force on the Magdeburg Plates
- F_{AP} = total atmospheric pressure
- F_{R} = residual pressure in the evacuated chamber
- πr^2 = surface area enclosed by the O-ring

to determine the theoretical force that holds the Magdeburg Plates together.

Procedure

1. Determine the diameter of the surface enclosed by the O-ring by measuring the outer and inner diameters of the O-ring. Then find the average of these two diameters. See Figure 1.1
2. Assemble the Magdeburg Plates with the connection for *ScienceWorkshop* (Figure 1.2), and pull a vacuum in the interior chamber with the vacuum pump.
3. Using a *ScienceWorkshop* interface and Pressure Sensor, measure the pressure inside the chamber (or assume it is 5 kPa).
4. Measure the atmospheric pressure using a barometer, a PASCO CI-6531

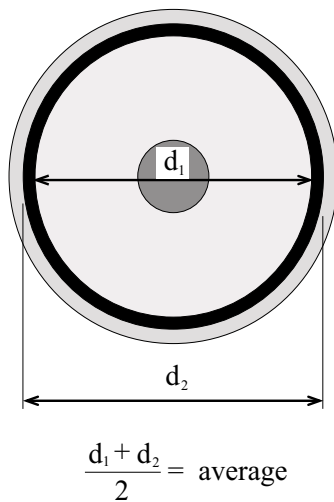

Figure 1.1
Measuring the diameter of the surface enclosed by the O-ring

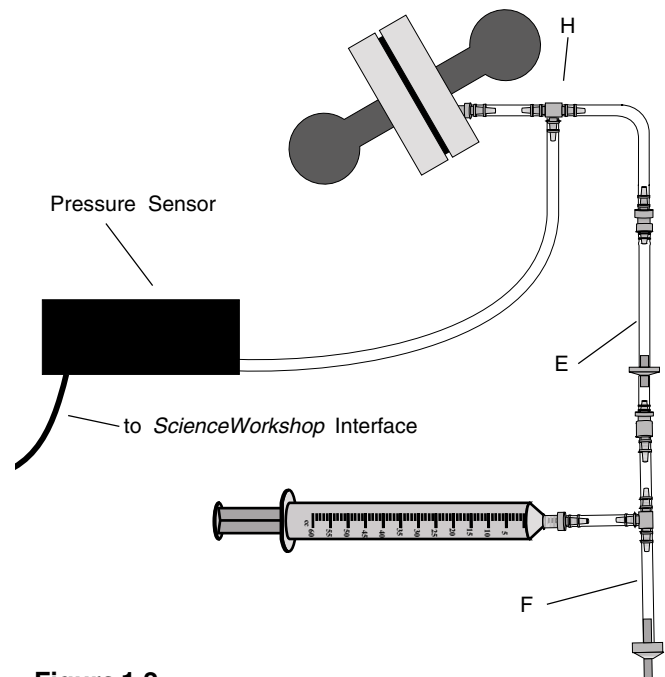

Figure 1.2
Experiment Setup for Activity 1

Barometer Sensor, or a PASCO CI-6532 Absolute Pressure Sensor.

Note: If you are not near sea level and you use a barometer or a media report of barometric pressure, be sure that the reading has not been “corrected to sea level” as is commonly done. A call to a local weather station should request “station pressure not corrected to sea level.” 101kPa is a typical value at sea level.

5. If necessary, convert the atmospheric pressure readings to kPa (refer to Physics reference materials, if necessary).
6. Calculate the Net Force that holds the plates together using the relationship:

$$F_{\text{NET}} = (F_{\text{AP}} - F_{\text{R}}) * \pi r^2$$

Note: 1 Pascal = 1 N/m² and 1 lb is approximately equal to 4.45 N.

(Try to pull the plates apart to appreciate the amount of this force.)

7. Repeat the calculation for the small O-ring.

Activity 2 Experimentally determining the force holding the plates together (small O-ring)

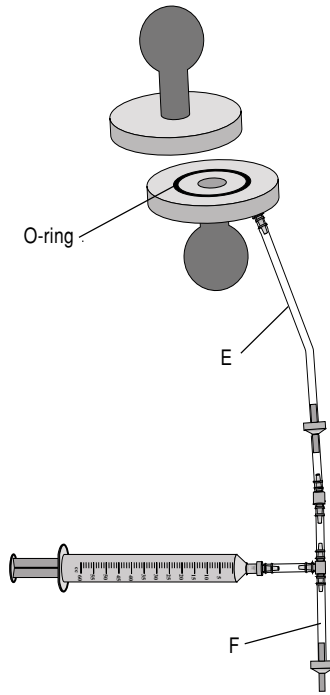

Figure 2.1
Experimental Setup for
Activity 2

1. Assemble the plates using the small O-ring and pull a vacuum in the inter-plate space (Figure 2.1).
2. Have a light, strong student stand on a bathroom scale (Figure 2.2) holding one handle of the Magdeburg Plates.

3. A strong person will kneel in front and pull on the second handle.
4. A third person will monitor the readout on the scales to note the highest value.

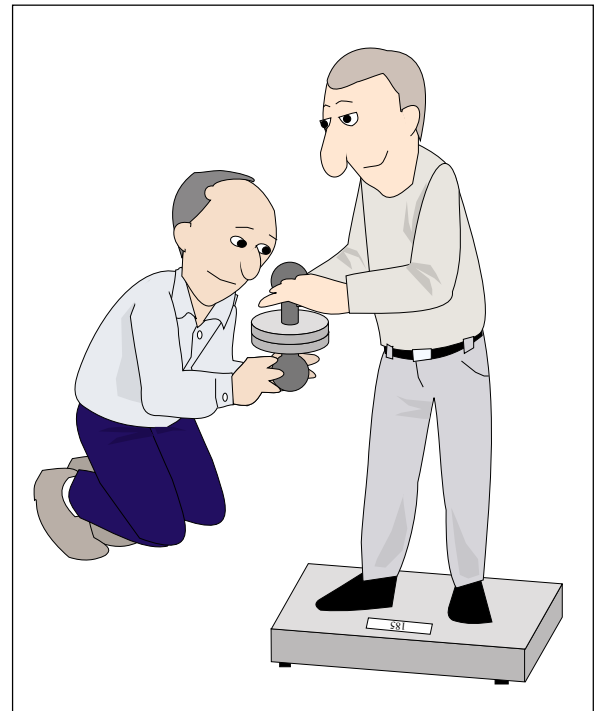

Figure 2.2
Applying the external force to pull the plates apart

5. The two students will pull the plates apart with a slow, and steadily increasing force while the third person notes the highest value.
6. Calculate the force required to break the plates (Total weight - person's weight and the weight of the Magdeburg plates)
7. If the scale read in pounds, multiply by 4.45 to get newtons. If it reads in kg, multiply by 9.8 to get newtons.

Compare with the calculated force in activity 1.

Note: Due to the large force required to break the plates sealed with the large O-ring, this experiment cannot be done — or would be dangerous to do — with the large O-ring.

Activity 3 Measuring the vacuum pulled and observe the rate of decay using ScienceWorkshop

Introduction

You can use a *ScienceWorkshop* Interface, computer, and Pressure Sensor to monitor the pressure in the chamber between the plates.

Procedure

1. Assemble the Magdeburg plates so the chamber pressure can be monitored with a Pressure Sensor and ScienceWorkshop Computer Interface (Figure 3.1)
2. Set up the Pressure Sensor in your data acquisition software (DataStudio or *ScienceWorkshop*) and open a Graph display.
3. Set the sampling rate on the Pressure Sensor to 1 sample/s.
4. Start collecting data.
5. Pull a vacuum in the chamber with the syringe.
6. Allow the plates to sit undisturbed for a few minutes.
7. Every minute or so, try to break the plates apart.
8. Note the pressure at which you were successful at breaking apart the plates, and calculate the force that was required. (Use the procedure detailed in Activity 1.)

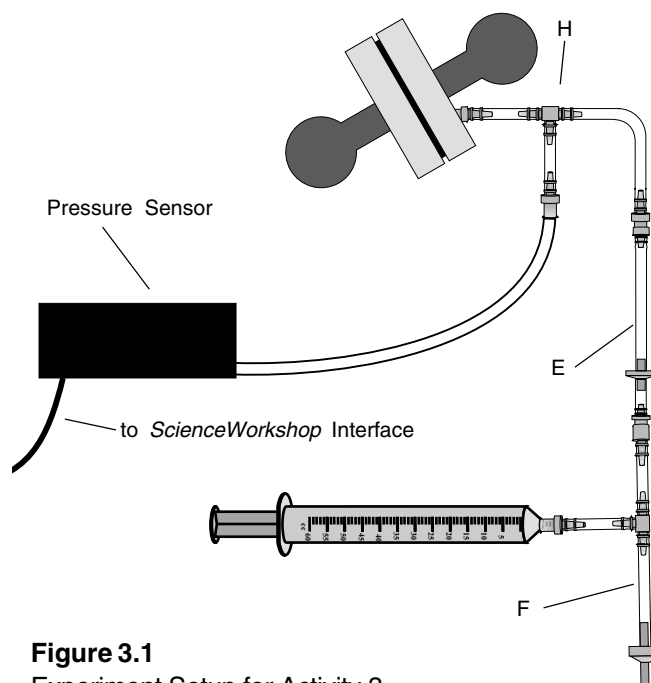

Figure 3.1
Experiment Setup for Activity 3

Note: When using the CI-6533 Differential Pressure Sensors, you must subtract the atmospheric pressure at your location by measuring it with a mercury barometer, with a CI-6531 Barometer, or by calling the local weather bureau. If you are not near sea level, be sure that the reading has not been “corrected to sea level” as is commonly done. A call to a local weather station should request “station pressure not corrected to sea level.” 101kPa is a typical value at sea level.

Activities with the Magdeburg Plate Accessories

Activity 4 Determining the effect of air pressure on the boiling temperature of water

Introduction:

Boiling occurs when a liquid reaches a temperature at which the *vapor pressure* of the liquid equals the air pressure. The vapor pressure of the liquid is dependent on both the air pressure and the temperature of the liquid. Normally, we make a liquid boil by heating it to increase the kinetic energy of the molecules. However, in this experiment, we will make the liquid boil by adjusting the air pressure rather than the temperature of the liquid.

Procedure

1. Assemble the Magdeburg Plates and the extra cylinder, plate, and O-ring from the Accessories kit as shown in Figure 4.1.

Note: Fit the O-rings into the grooves on the plate, cylinder, and base.

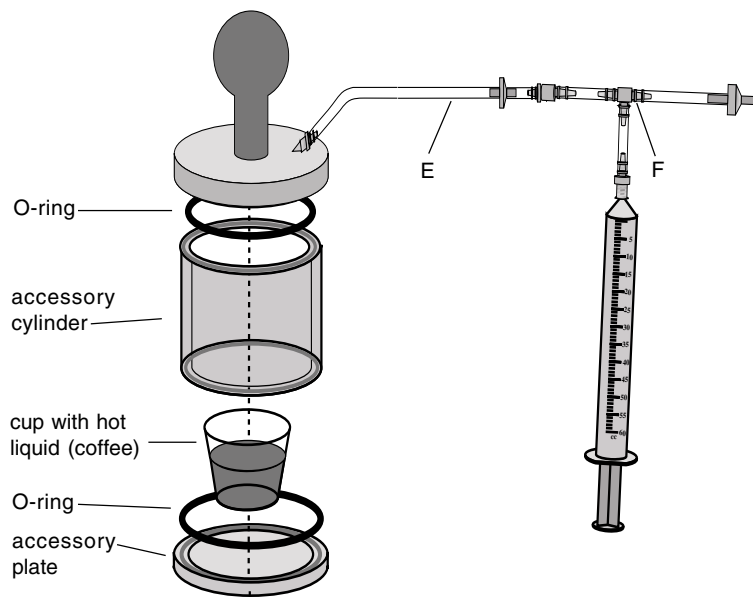
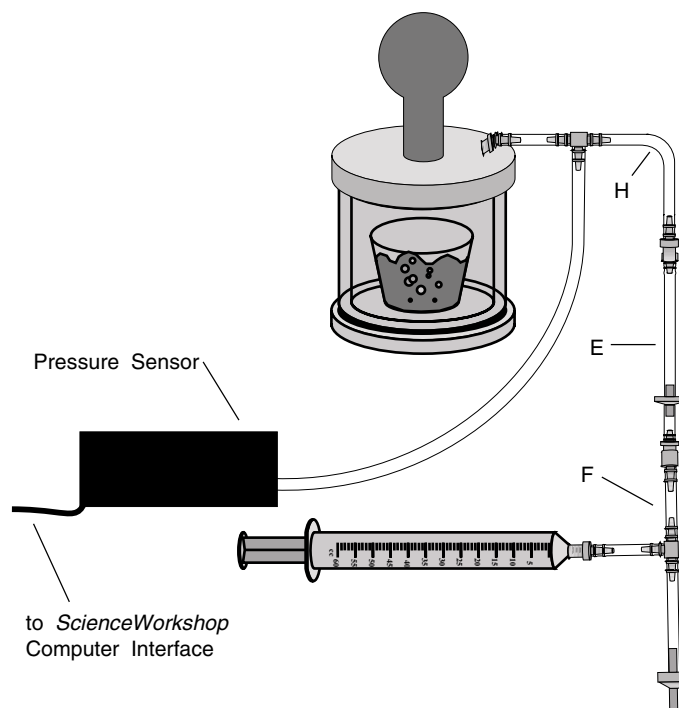

Figure 4.1
Experiment setup for Activity 4

Optional Procedure:

You can also include a connection to an Absolute Pressure Sensor to monitor the pressure inside the chamber as in Figure 4.2.

**Figure 4.2**

Optional setup with *ScienceWorkshop* and a Pressure Sensor

Hint: Apply pressure to the top plate during the first few strokes of the plunger until a vacuum starts to form.

2. Fill the plastic cup halfway with hot coffee or very hot tap water.
3. Measure the temperature of the liquid.
4. Start recording data if you are monitoring the pressure, and pull a vacuum with the syringe. Watch the liquid carefully. What do you observe?
5. What do you think is happening to the temperature of the liquid?
6. Loosen the connection to A slowly to release the vacuum, then measure the temperature of the liquid. A quick release of the vacuum may cause the hot liquid to splatter.

Activity 5

Investigating the effect of air pressure on the size of a balloon.

Procedure:

1. Set up the Magdeburg Apparatus as described in Activity 4, replacing the cup of hot liquid a balloon.
2. Inflate the balloon slightly so the rubber is almost tight but not stretched. Tie off the neck.
3. Pull a vacuum and notice the size of the balloon.

Note: You can also use the bubble-wrap included in the Accessories kit in this experiment.

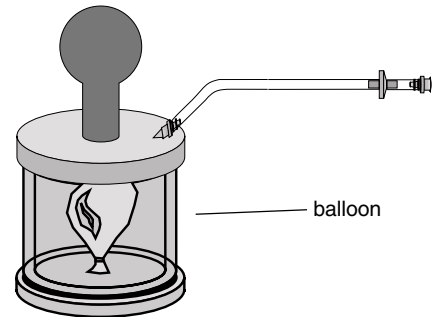

Figure 5.1
Setup for Activity 5

Activity 6

Investigating the effect of air pressure on a suction cup

1. Put the suction cup from the Accessories kit on the underside of the top plate of the chamber.
2. Pull a vacuum and observe the result.

Teacher's Notes

Activity 1

Sample data:

outside diameter of the large O-ring = 9.5 cm

inside diameter of the large O-ring = 8.5 cm

average of inside and outside diameter = 9.0 cm

Net Force = (atmospheric pressure - pressure inside the chamber) * π * (9.0 cm/2)²

Net Force = (101 KPa - 5 KPa) * π * (9.0 cm/2)²

Net Force = (96 KPa) * 3.14 * (9.0 cm/2)²

(1 Pascal = 1 N/m², and cm is meters x 10⁻²)

Net Force = (96 x 10³ N/m²) * 3.14 * (9.0 m x 10⁻²/2)²

Net Force = 610 N (approximately 137 lb or the weight of a 62 kg object)

(1 lb is approximately equal to 4.45 N; 1 kg is approximately 9.8 N)

Net Force = 137 pounds

Calculation with the small O-ring

outside diameter of the small O-ring = 6.0 cm

inside diameter of the small O-ring = 5.0 cm

Using the procedures and assumptions from the above example

Net Force = (96 x 10³ N/m²) * 3.14 * (5.5 cm x 10⁻²/2)²

Net Force = 228 N (approximately 51 lb or the weight of a 23 kg object)

Activity 3

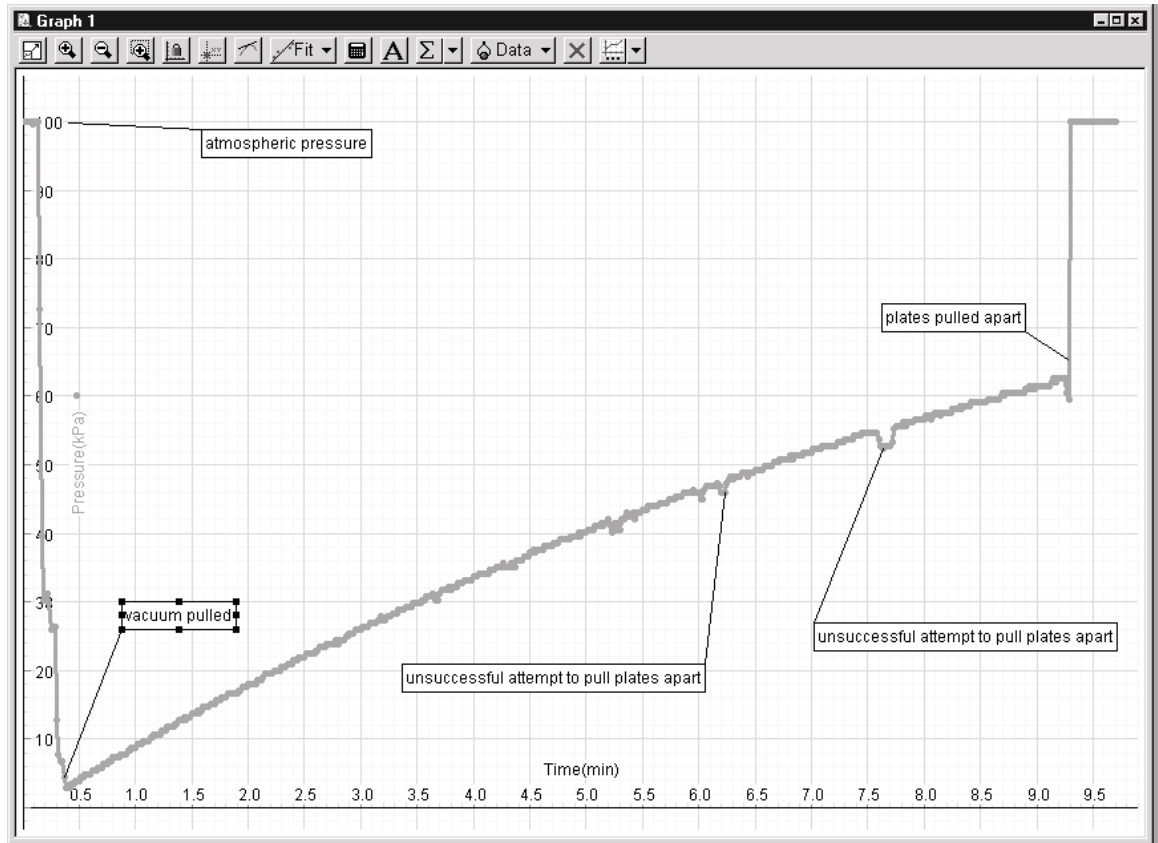

Figure TN_1
Sample data for Activity 3

Activity 4

Result: The coffee will boil when you have created at strong vacuum (about 20 pulls on the syringe plunger). The temperature of the coffee will decrease after boiling. Boiling is endothermic.

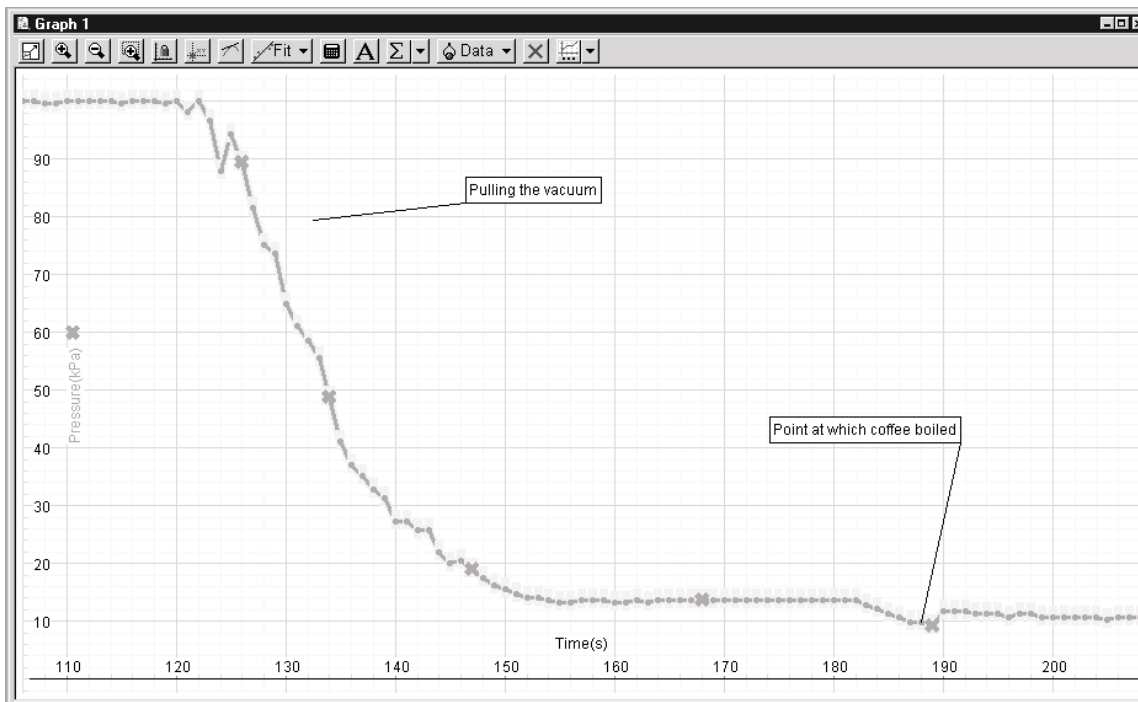

Figure TN_2
Sample data for Activity 4

Activity 5

The balloon will start expanding visibly when the pressure reaches about 60 kPa and will continue to expand until the maximum vacuum has been reached or until the balloon blocks the hose port.

Activity 6

The suction cup will fall off when a pressure of about 50 kPa is reached.

Technical Support

Feedback

If you have any comments about the product or manual, please let us know. If you have any suggestions on alternate experiments or find a problem in the manual, please tell us. PASCO appreciates any customer feedback. Your input helps us evaluate and improve our product.

To Reach PASCO

For technical support, call us at 1-800-772-8700 (toll-free within the U.S.) or (916) 786-3800.

fax: (916) 786-3292

e-mail: techsupp@pasco.com

Web site: www.pasco.com

Contacting Technical Support

Before you call the PASCO Technical Support staff, it would be helpful to prepare the following information:

- If your problem is with the PASCO apparatus, note:
 - Title and model number (usually listed on the label);
 - Approximate age of apparatus;
 - A detailed description of the problem/sequence of events (in case you can't call PASCO right away, you won't lose valuable data);
 - If possible, have the apparatus within reach when calling to facilitate description of individual parts.

- If your problem relates to the instruction manual, note:
 - Part number and revision (listed by month and year on the front cover);
 - Have the manual at hand to discuss your questions.