



Heavy Duty Voltmeter

SF-9568A

Introduction

The PASCO Model SF-9568A Heavy Duty Voltmeter is a rugged yet sensitive instrument designed specifically for student experiments. It has three ranges and is switch selectable by input jack to measure AC or DC values.

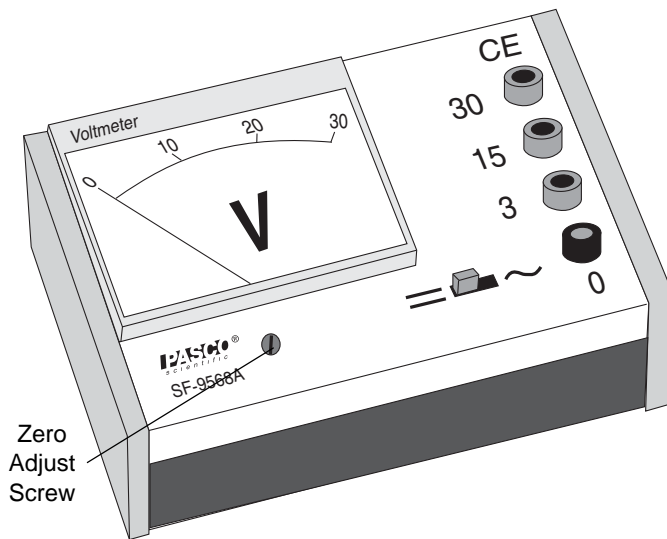

- Determine the range. For both AC and DC measurements, voltage may be measured in one of three ranges: 3 V, 15 V, and 30 V. The range is selected by plugging leads (not included) into the appropriate input jack.

NOTE: To project the meter, always choose a range that is higher than the highest voltage you might expect in the circuit.

- Attach leads to the circuit points between which you wish to measure the voltage.

For AC measurements

Plug one lead of the circuit into the black input jack and the other lead into the red input jack of the appropriate range.

For DC measurements

Connect the leads in such a way that positive current flows into the black input connector on the voltmeter.

Operation

To zero the meter:

Place the meter in the position (vertical or horizontal) in which it will be used. Disconnect the meter. Use a small, standard blade screwdriver to turn the Zero Adjust Screw (located on the case below the meter) until the meter needle is aligned with zero on the scale.

NOTE: If the meter is zeroed in one position and the position is changed, it may need to be zeroed again.

To measure voltage:

- Set the selection switch for AC or DC voltage. (The AC setting will provide root-mean-square (RMS) readings for alternating current circuits.)

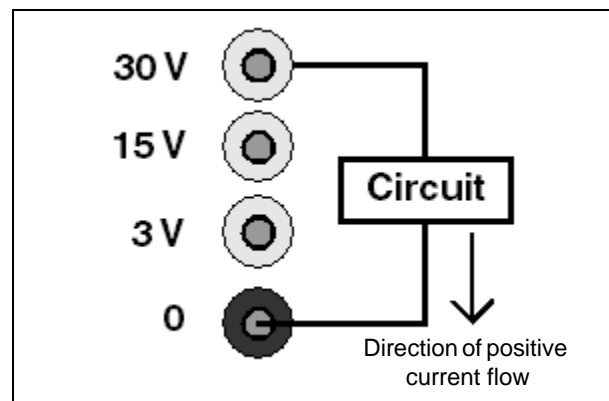

- Now you can read the voltage on the meter. A full swing of the needle corresponds to the value in the chosen range selection. For example, on the 3 V range, a reading of 20 on the upper scale indicates a voltage of 2.0 V.

Specifications

| | |
|--------------------------------|--------------------------------------------------|
| Ranges (AC and DC) | 0 to 3 V, 15 V, and 30 V |
| Accuracy | ± 2% of full scale |
| Scale Length | 6.2 cm |
| Sensitivity | 10 k Ω per V |
| Impedance | 0–3V, 39 k Ω /V; 0–15V, 150 k Ω /V |
| Frequency Response (AC) | 20 Hz to 50 kHz, ± 3 dB |

Limited Warranty

For a description of the product warranty, see the PASCO catalog.

Copyright

The PASCO scientific 012-08015B *Heavy Duty Voltmeter Instruction Sheet* is copyrighted with all rights reserved. Permission is granted to non-profit educational institutions for reproduction of any part of this manual, providing the reproductions are used only in their laboratories and classrooms, and are not sold for profit. Reproduction under any other circumstances, without the written consent of PASCO scientific, is prohibited.

Trademarks

PASCO and PASCO scientific are trademarks or registered trademarks of PASCO scientific, in the United States and/or in other countries. All other brands, products, or service names are or may be trademarks or service marks of, and are used to identify, products or services of, their respective owners. For more information visit www.pasco.com/legal

Product End of Life Disposal Instructions:

This electronic product is subject to disposal and recycling regulations that vary by country and region. It is your responsibility to recycle your electronic equipment per your local environmental laws and regulations to ensure that it will be recycled in a manner that protects human health and the environment. To find out where you can drop off your waste equipment for recycling, please contact your local waste recycle/disposal service, or the product representative.

The European Union WEEE (Waste Electronic and Electrical Equipment) symbol and on the product or its packaging indicates that this product **must not** be disposed of in a standard waste container.



Technical Support

For assistance with any PASCO product, contact PASCO at:

Address: PASCO scientific
10101 Foothills Blvd.
Roseville, CA 95747-7100

Phone: 916-786-3800 (worldwide)
800-772-8700 (U.S.)

Fax: (916) 786-7565

Web: www.pasco.com

Email: support@pasco.com

For the latest information about the Heavy Duty Voltmeter, go to the PASCO web site at www.pasco.com and enter SF-9568A in the search window.