

**Instruction Manual and
Experiment Guide for
the PASCO scientific
Model ME-8960**

012-05327B
4/94

DEMONSTRATION GYROSCOPE

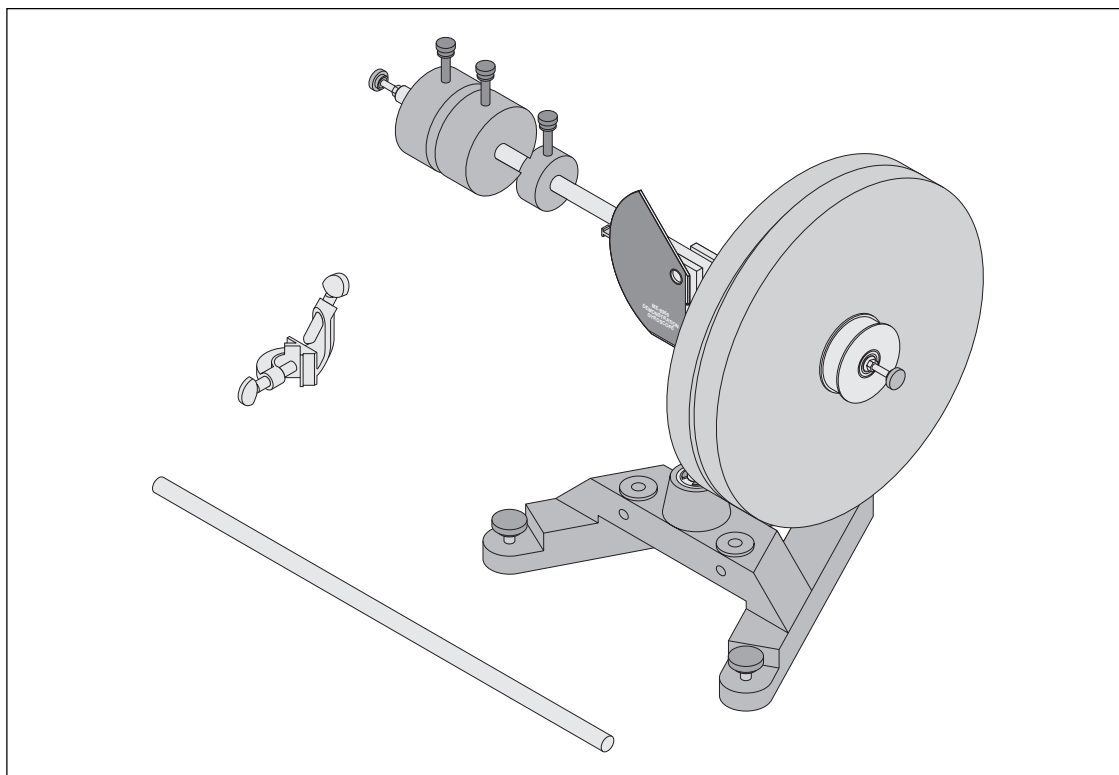

© 1994 PASCO scientific

\$10.00

PASCO
scientific

10101 Foothills Blvd. • P.O. Box 619011 • Roseville, CA 95678-9011 USA
Phone (916) 786-3800 • FAX (916) 786-8905 • TWX 910-383-2040

better

ways to

teach physics

Table of Contents

Section	Page
Copyright, Warranty, and Equipment Return	ii
Introduction	1
Equipment	2
Assembly	
ME-8960 Demonstration Gyroscope	3
ME-8961 Additional Gyroscope Disk	5
Experiments	
Experiment 1: Precession	7
Experiment 2: Counter-rotating Disks - Demonstration	13
Experiment 3: Precession - Demonstration	15
Experiment 4: Nutations - Demonstration	17
Technical Support	Back Cover

Copyright, Warranty and Equipment Return

Please—Feel free to duplicate this manual subject to the copyright restrictions below.

Copyright Notice

The PASCO scientific Model ME-8960 Demonstration Gyroscope manual is copyrighted and all rights reserved. However, permission is granted to non-profit educational institutions for reproduction of any part of this manual providing the reproductions are used only for their laboratories and are not sold for profit. Reproduction under any other circumstances, without the written consent of PASCO scientific, is prohibited.

Limited Warranty

PASCO scientific warrants this product to be free from defects in materials and workmanship for a period of one year from the date of shipment to the customer. PASCO will repair or replace, at its option, any part of the product which is deemed to be defective in material or workmanship. This warranty does not cover damage to the product caused by abuse or improper use. Determination of whether a product failure is the result of a manufacturing defect or improper use by the customer shall be made solely by PASCO scientific. Responsibility for the return of equipment for warranty repair belongs to the customer. Equipment must be properly packed to prevent damage and shipped postage or freight prepaid. (Damage caused by improper packing of the equipment for return shipment will not be covered by the warranty.) Shipping costs for returning the equipment, after repair, will be paid by PASCO scientific.

Credits

This manual authored by: Jon Hanks

This manual edited by: Jon Hanks

Equipment Return

Should this product have to be returned to PASCO scientific, for whatever reason, notify PASCO scientific by letter or phone BEFORE returning the product. Upon notification, the return authorization and shipping instructions will be promptly issued.

► **NOTE:** NO EQUIPMENT WILL BE ACCEPTED FOR RETURN WITHOUT AN AUTHORIZATION.

When returning equipment for repair, the units must be packed properly. Carriers will not accept responsibility for damage caused by improper packing. To be certain the unit will not be damaged in shipment, observe the following rules:

- ① The carton must be strong enough for the item shipped.
- ② Make certain there is at least two inches of packing material between any point on the apparatus and the inside walls of the carton.
- ③ Make certain that the packing material can not shift in the box, or become compressed, thus letting the instrument come in contact with the edge of the box.

Address: PASCO scientific
 10101 Foothills Blvd.
 P.O. Box 619011
 Roseville, CA 95678-9011

Phone: (916) 786-3800
 FAX: (916) 786-8905

Introduction

The PASCO ME-8960 Gyroscope has an open design that makes all the parts easily accessible to the student. The gyroscope consists of a disk that can be rotated by hand or by pulling a string that is wrapped around the pulley. A movable counterweight balances the disk.

The small counterweight is used to make fine adjustments to the balance. An add-on mass can be easily placed on the end of the shaft to cause a torque and precession. The rotational inertia of the disk is easily obtained by accelerating the disk using a string around the pulley that is attached to the disk.

Equipment

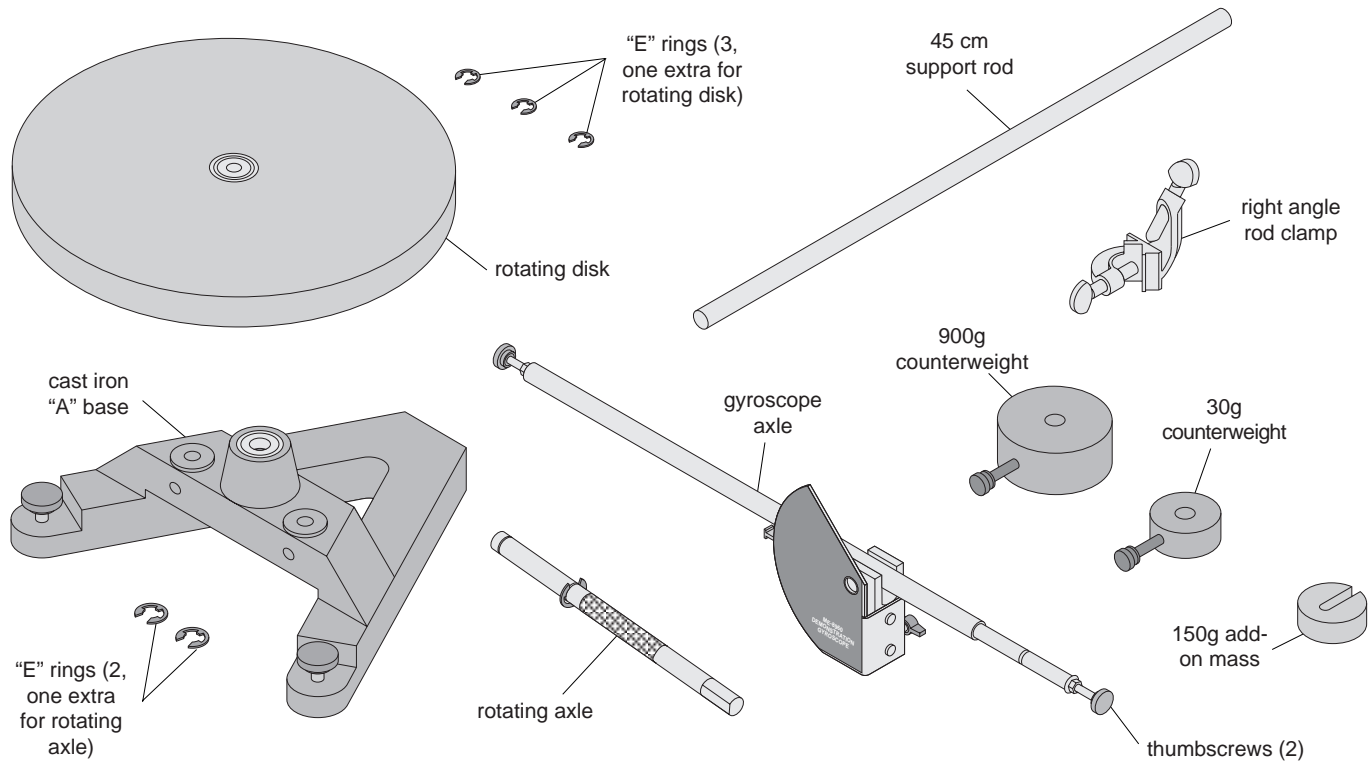

ME-8960 Demonstration Gyroscope Equipment

The ME-8960 Demonstration Gyroscope includes the following:

- | | |
|--|--|
| <ul style="list-style-type: none"> – PASCO cast iron “A” base with rotating shaft – axle (48 cm long) with pivot block, protractor plate, and pointer – one 900g large counterweight – one 30g small counterweight – one 150g add-on mass | <ul style="list-style-type: none"> – 25cm diameter rotating disk with pulley – 45 cm support rod – right angle rod clamp – extra “E” rings to secure rotating shaft and rotating disk – two thumbscrews |
|--|--|

The ME-8961 Additional Gyroscope Disk includes the following:

- 25cm diameter rotating disk with pulley
- one 900g large counterweight

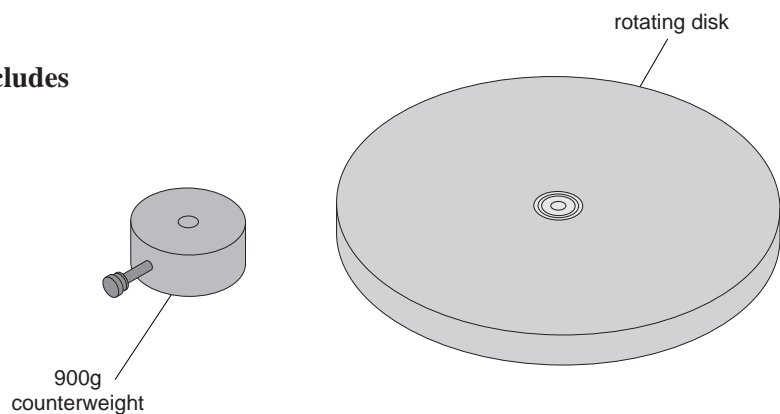

ME-8961 Additional Gyroscope Disk

Assembly

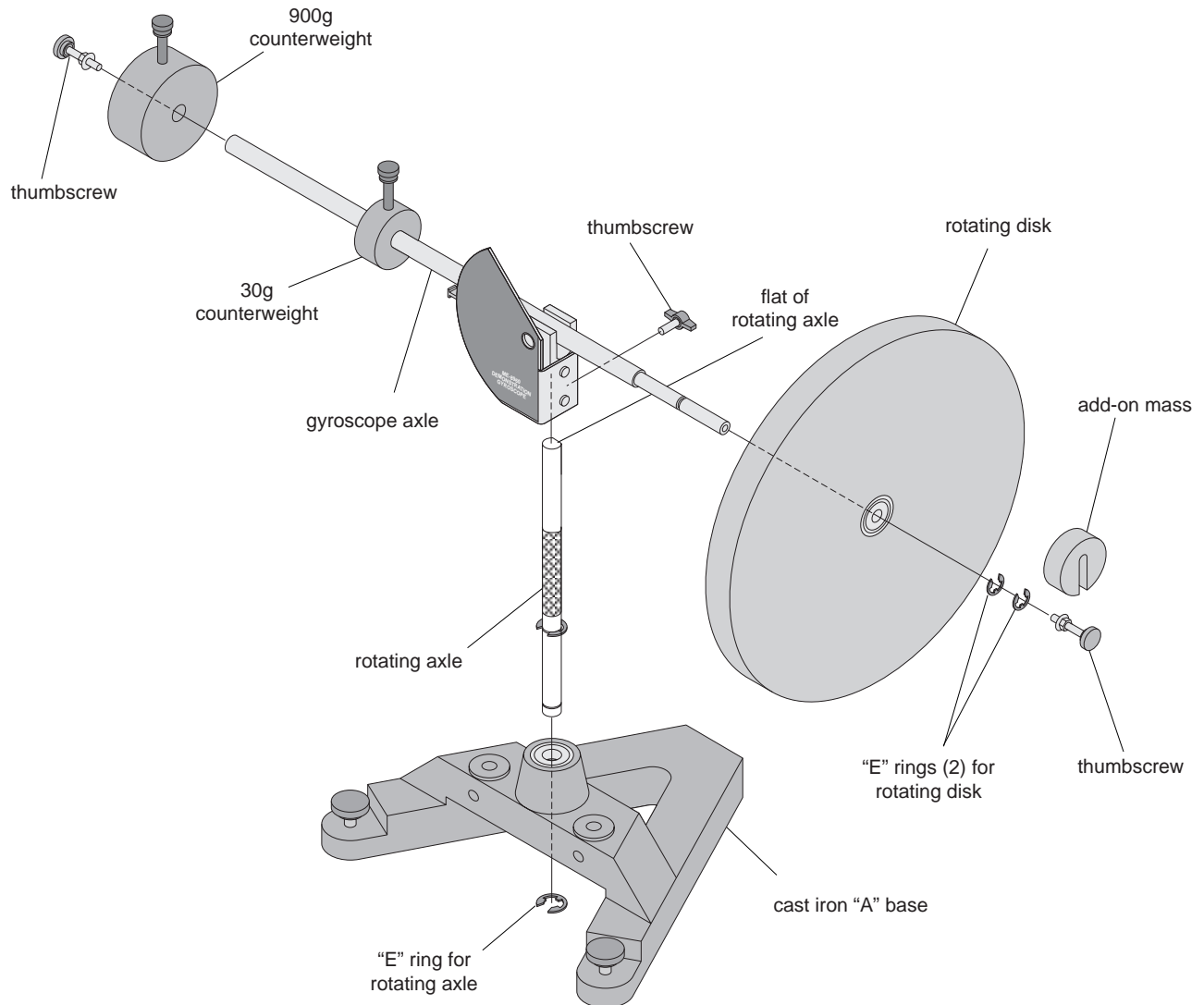

Figure 1: Demonstration Gyroscope Assembly

ME-8960 Demonstration Gyroscope

Assembling the Demonstration Gyroscope

- ① Insert the cylindrical end of the vertical shaft into the bearings on the top-side of the A-shaped iron base. Secure the shaft in place by inserting the retaining ring in the slot at the bottom of the shaft. See Figure 1.
- ② Attach the gyroscope axle to the vertical shaft and tighten the thumb screw against the flat side of the "D" on the vertical shaft.
- ③ Slide the smaller of the two counterweights (30g) onto the long side of the gyroscope axle and tighten the thumbscrew. Then slide the larger of the two counterweights (900g) onto the same end of the shaft and tighten its thumbscrew.
- ④ Put the disk on the other end of the gyroscope axle with the pulley side of the disk facing the center of the gyro. Secure the disk in place with the retaining rings (2). See Figure 1.
- ⑤ Screw the thumbscrew into the end of the shaft until the nut is tight against the end of the shaft

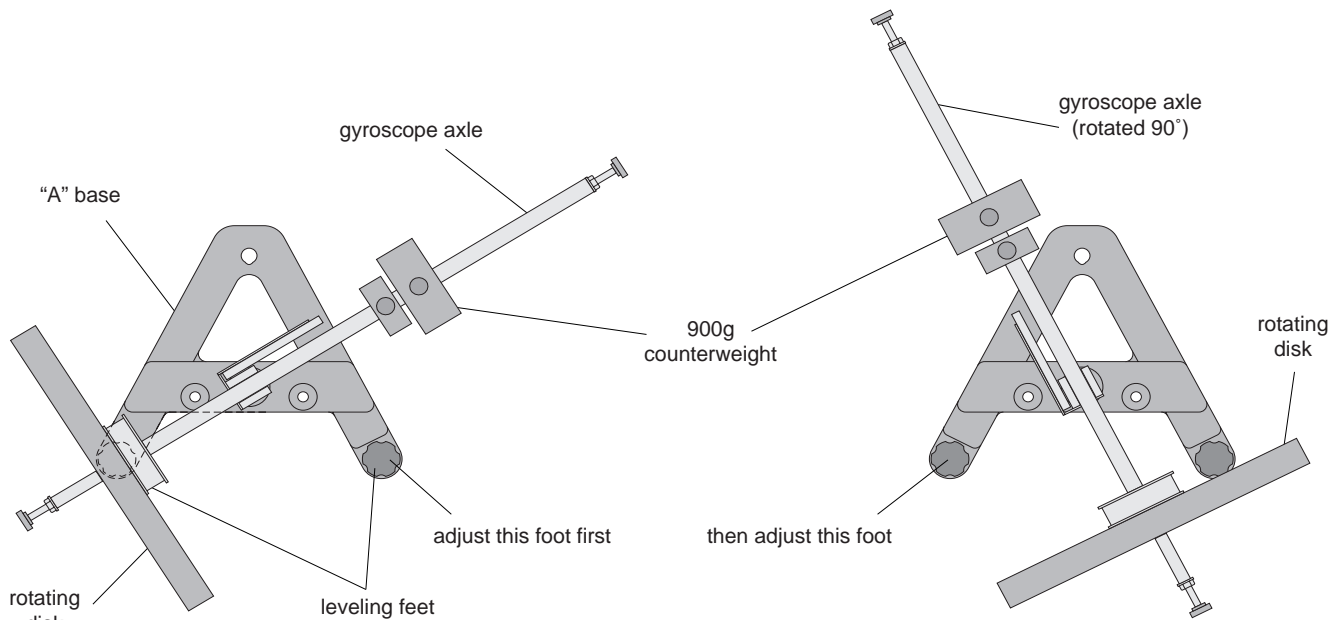

Figure 2: Leveling the Base

Leveling the Base

- ① Purposely make the apparatus unbalanced by moving the 900g counterweight towards the center.
- ② Adjust the leveling foot on one of the legs of the base until the gyroscope disk is aligned over the leveling foot on the other leg of the base. See Figure 2.
- ③ Rotate the gyroscope 90 degrees so the gyroscope axle is parallel to one side of the “A” and adjust the other leveling foot until the shaft will stay in this position. See Figure 2.
- ④ Adjust the position of the 900g counterweight until the gyroscope is balanced without the add-on mass. The 30g counterweight can be used to fine tune the balance.

Using the Rotating Disk Pulley

- ① Make sure the rotating disk is secure on the gyroscope axle and decide which direction you want the disk to rotate.
- ② Tie a loop in the end of a length of thread (approximately 1.5 meters long) and put the loop around the dowel pin located on the surface of the rotating disk pulley and wind the thread around the surface of the pulley. See Figure 3.
- ③ Holding the gyroscope axle in place, pull the thread to rotate the disk at the desired speed.

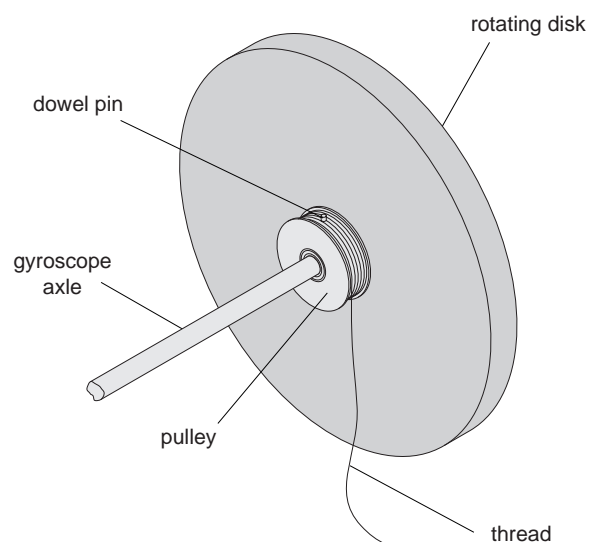

Figure 3: Using the Rotating Disk Pulley

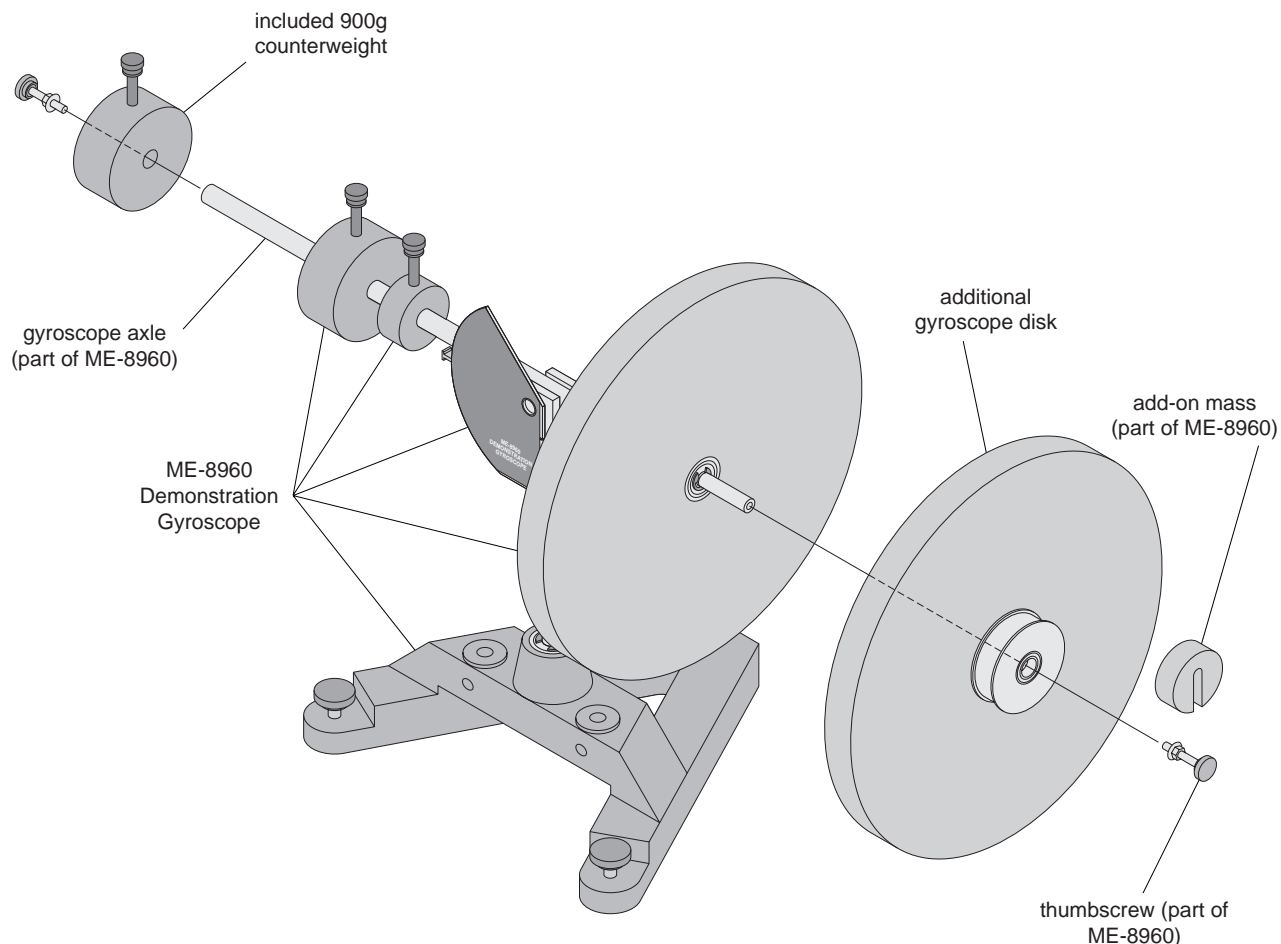

Figure 4: Using the Additional Gyroscope Disk

ME-8961 Additional Gyroscope Disk

Using the Additional Gyroscope Disk

- ① Slide the included 900g counterweight onto the long side of the gyroscope axle and tighten the thumbscrew.
- ② Put the Additional Gyroscope Disk on the other end of the gyroscope axle with the pulley side of the disk facing away from the center of the gyroscope apparatus. Secure the disk in place with the supplied thumbscrew. See Figure 4.

Notes:

Experiment 1: Precession

EQUIPMENT NEEDED

- | | |
|---|--|
| <ul style="list-style-type: none"> – Gyroscope (ME-8960) – stopwatch (SE-8702) – Super Pulley (ME-9450) – Pulley Mounting Rod (SA-9242) – Mass and Hanger Set (ME-9348) – balance | <ul style="list-style-type: none"> – meter stick – table clamp for pulley – thread (1.5 meters) – computer (optional) – Smart Pulley (optional) – Smart Pulley software (optional) |
|---|--|

Purpose

The purpose of this experiment is to measure the precession rate of a gyroscope and compare it to the theoretical value.

Theory

A torque is applied to the gyroscope by hanging a mass on the end of the shaft. This torque causes the gyroscope to precess at a certain angular speed, Ω .

Assume that the gyroscope is initially balanced in the horizontal position, $\theta = 90^\circ$. The disk is spun at an angular speed (ω) and then a mass, m , is attached to the end of the gyroscope shaft at a distance, d , from the axis of rotation. This causes a torque: $\tau = mgd$. But the torque is also equal to dL/dt , where L is the angular momentum of the disk. As shown in Figure 1.1, for small changes in angle, $d\phi$, $dL = L d\phi$.

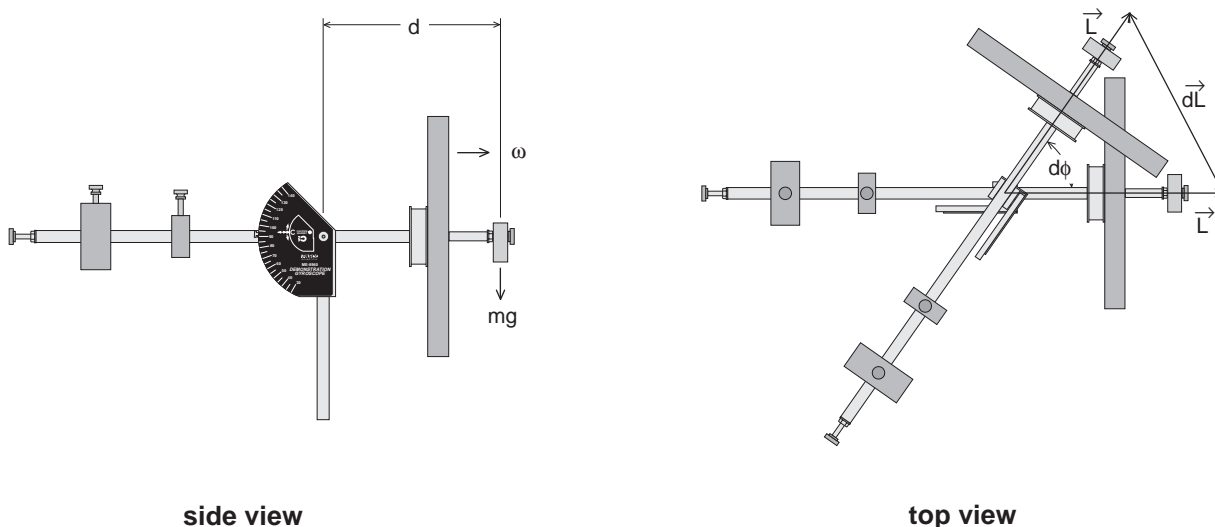

Figure 1.1: Torque Applied to Horizontal Gyroscope

Substituting for dL in the torque equation gives

$$\tau = mgd = \frac{dL}{dt} = L \frac{d\phi}{dt}$$

Since $d\phi/dt = \Omega$, the precession speed,

$$mgd = L\Omega$$

and the precession rate is given by

$$\Omega = \frac{mgd}{I\omega}$$

where I is the rotational inertia of the disk and ω is the angular speed of the disk.

To find the rotational inertia of the disk experimentally, a known torque is applied to the disk and the resulting angular acceleration is measured. Since $\tau = I\alpha$,

$$I = \frac{\tau}{\alpha}$$

where α is the angular acceleration which is equal to a/r and τ is the torque caused by the weight hanging from the thread which is wrapped around the pulley on the disk.

$$\tau = rF$$

where r is the radius of the pulley about which the thread is wound and F is the tension in the thread when the disk is rotating.

Applying Newton's Second Law for the hanging mass, m , gives (See Figure 1.2)

$$\Sigma F = mg - F = ma$$

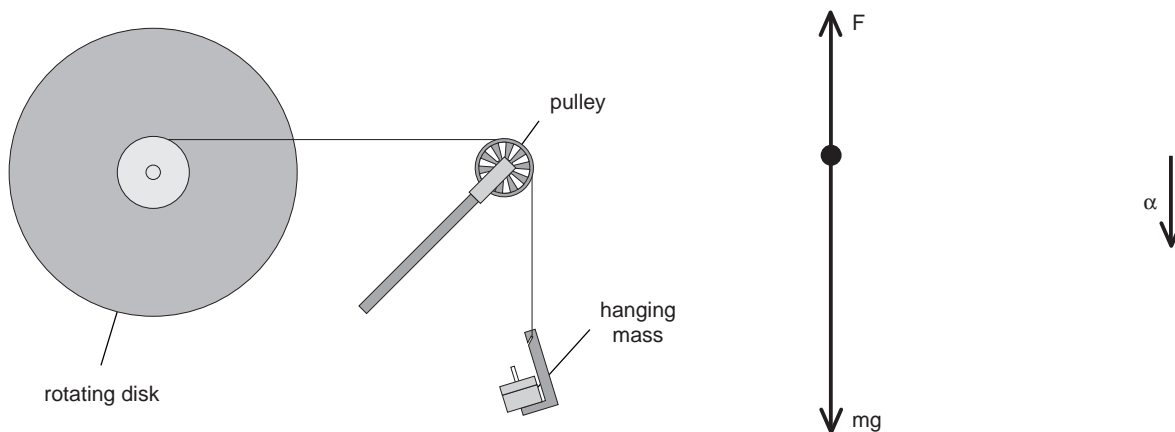

Figure 1.2: Rotating Disk and Free-Body Diagram

Solving for the tension in the thread gives

$$F = m(g - a)$$

So, once the linear acceleration of the mass (m) is determined, the torque and the angular acceleration can be obtained for the calculation of the rotational inertia. The acceleration is obtained by timing the fall of the hanging mass as it falls from rest a certain distance (y). Then the acceleration is given by

$$a = \frac{2y}{t^2}$$

Part I: Measuring the Precession Rate

Setup

- ① Level the gyroscope base as described on page 4 in the Assembly section of this manual.
- ② Adjust the position of the large counterweight until the gyroscope is balanced without the add-on mass. The small counterweight can be used to fine-tune the balance.

Procedure

- ① Weigh the add-on mass and record its mass in Table 1.1. Attach the add-on mass to the end of the shaft. Measure the distance (d) from the axis of rotation to the center of the add-on mass. Record this distance in Table 1.1
- ② While holding the gyroscope so it can't precess, spin the disk at about two revolutions per second. Time 10 revolutions of the disk to determine the angular speed (ω) of the disk. Record in Table 1.1.
- ③ Let the gyroscope precess and time two revolutions to find the precession rate. Record in Table 1.1.
- ④ Immediately repeat the measurement of 10 revolutions of the disk. The before-and-after

Table 1.1: Angular Speed Measurements

Add-On Mass	
Distance (d)	
Time for 10 Revolutions (initial)	
Time for Precession	
Time for 10 Revolutions (final)	

data will be used to find the average angular speed of the disk during the precession.

Part II: Measuring Quantities For the Theoretical Value

Setup

- ① Clamp the gyroscope shaft in the horizontal position. See Figure 1.3.
- ② Attach a Super Pulley with rod to the table using a table clamp.
- ③ Wind a thread around the pulley on the center shaft and pass the thread over the Super Pulley.

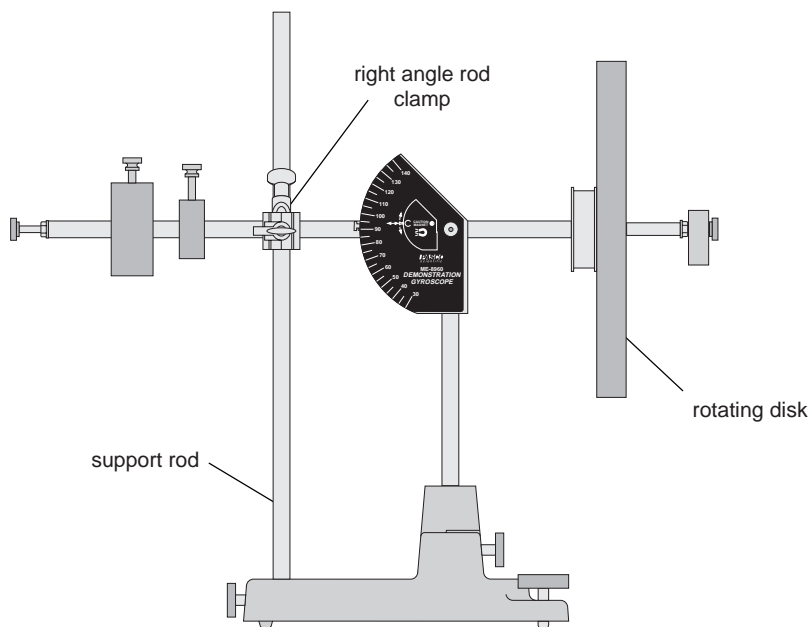

Figure 1.3: Experiment Setup

Procedure

Accounting For Friction

Because friction is not included in the theory, it will be compensated for in this experiment by finding out how much mass over the pulley it takes to overcome kinetic friction. When the mass drops at a constant speed, the weight of the mass is equal to the kinetic friction. Then this “friction mass” will be subtracted from the mass used to accelerate the apparatus.

- ① To find the mass required to overcome kinetic friction, put just enough mass hanging over the pulley so that the velocity is constant. Record this friction mass in Table 1.2.

Finding the Acceleration of the Disk

- ① To find the acceleration, put about 30 g (record the exact hanging mass in Table 1.2) over the pulley. Wind the thread up and let the mass fall from the table to the floor, timing the fall.
- ② Repeat this for a total of 5 times, always starting the hanging mass in the same position.
- ③ Measure the height that the mass falls and record this height in Table 1.2.

Alternate Computer Method:

If a computer and Smart Pulley are used, the acceleration of the disk can be obtained by finding the slope of the velocity vs. time graph.

Measure the Radius

- ① Using calipers, measure the diameter of the pulley about which the thread is wrapped and calculate the radius. Record the radius in Table 1.2.

Table 1.2 Rotational Inertia Data

Friction Mass	
Hanging Mass	
Height Mass Falls	
Radius of Pulley	
Times	
Average:	

Analysis

- ① Using the average time from Table 1.2, calculate the acceleration and record the result in Table 1.3.
- ② Calculate the rotational inertia:
- Subtract the “friction mass” from the hanging mass used to accelerate the disk to determine the mass, m , to be used in the equations.
 - Calculate the experimental value of the rotational inertia and record it in Table 1.3.
- ③ Using the times for 10 revolutions in Table 1.1, divide by 10 to find the periods. Average these two periods and calculate the average angular speed ($\omega = 2\pi/T$). Record the angular speed in Table 1.3.
- ④ Find the experimental value for the precession rate by dividing the precession time by two and calculating $\Omega = 2\pi/T$. Record in Table 1.3.
- ⑤ Calculate the theoretical value for the precession rate and record in Table 1.3.
- ⑥ Calculate the percent difference between the experimental and theoretical values of the precession rate.

Table 1.3: Results

Acceleration	
Rotational Inertia	
Average Angular Speed of Disk	
Experimental Precession Rate	
Theoretical Precession Rate	
% Difference	

Questions

- ① What happens to the direction of precession if the spin of the disk is reversed?
- ② How does the rate of precession change if the angular speed of the disk is increased?

Experiment 2: Counter-rotating Disks - Demonstration

EQUIPMENT NEEDED

- Gyroscope (ME-8960)
- Accessory Disk and Extra Counterweight (ME-8961)
- Physics String (SE-8050)

Purpose

It is shown that two disks spinning in opposite directions at the same angular speed will not precess when a torque is applied.

Setup

- ① Remove the screw in the end of the shaft and slide the second disk onto the shaft with the pulley side facing away from the first disk. Secure the second disk by tightening the screw in the end of the shaft. See Figure 2.1.
- ② Put the second counterweight on the other end of the shaft and slide the counterweights until the gyroscope is balanced. Spin the disks and check the balance by seeing if the gyroscope precesses. If it precesses, the balance needs further adjustment.
- ③ Cut two pieces of string, each 1 meter long. Tie one end of each string to the ends of a pen. The pen will be used to pull the two strings simultaneously. Tie a loop in the other end of each string to hook over the dowel pins.
- ④ To make the direction of rotation more visible to the students, stick a white paper dot on the edge of each disk.

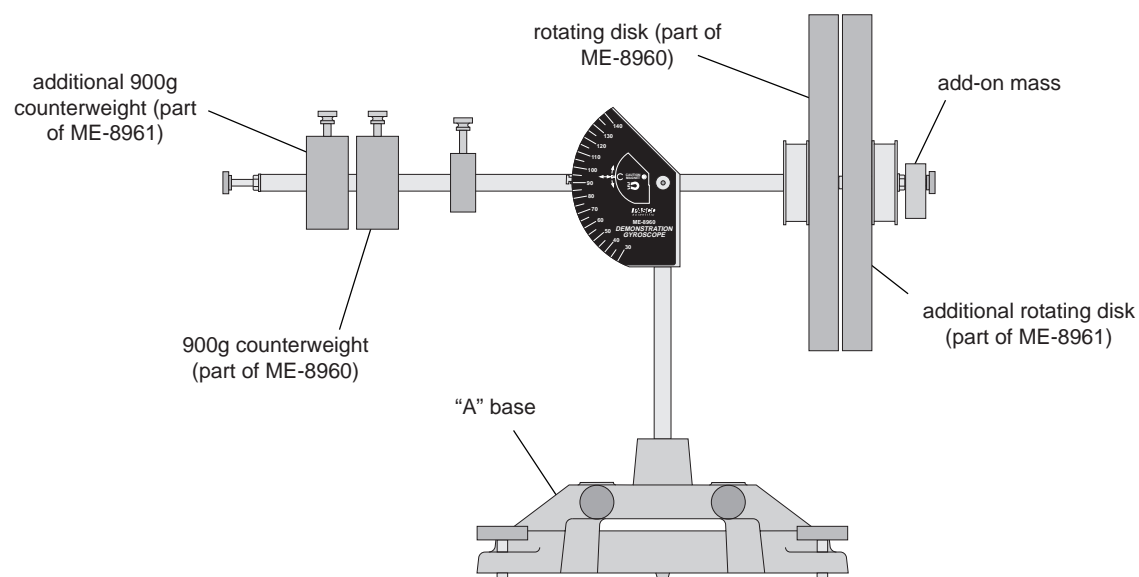

Figure 2.1: Counter-rotating disks

Procedure

- ① Use your hand to spin both disks in the same direction. Show that the gyroscope does not precess.
- ② Put the add-on mass on the end of the shaft and secure with a screw. Spin both disks in the same direction and show that the gyroscope now precesses.
- ③ Stop the disks and reverse the spin of both disks to show that the gyroscope now precesses in the opposite direction.
- ④ Now counter-rotate the disks. To do this, wrap an equal number of turns of string in opposite directions around the pulleys on each of the disks. Pull on both strings simultaneously using the pen as a handle. Point out that even though a torque is still being applied to the gyro, the gyroscope does not precess when the two disks are spinning in opposite directions.

Experiment 3: Precession - Demonstration

EQUIPMENT NEEDED

– Gyroscope (ME-8960)

Purpose

It is shown that if a precessing gyroscope is restricted from precessing, the disk will fall.
See Figure 3.1.

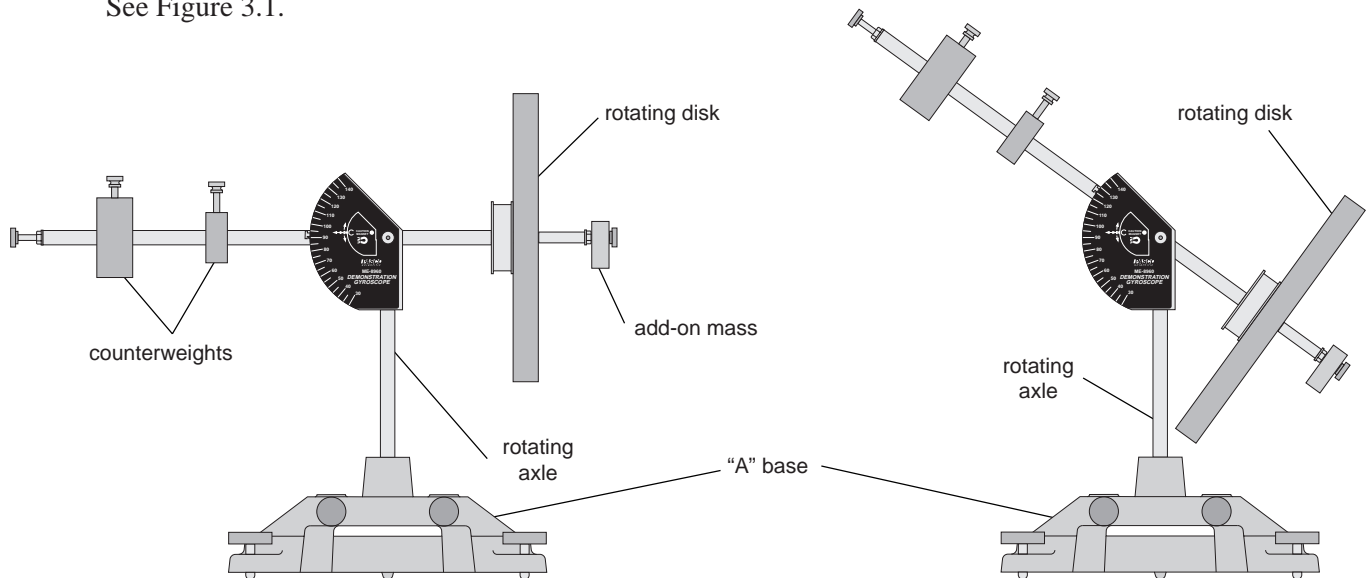

Figure 3.1: Precession

Procedure

- ① Adjust the counterweights until the gyroscope is balanced.
- ② Put the add-on mass on the end of the shaft.
- ③ Spin the disk and allow the gyroscope to precess.
- ④ Slow or stop the precession by grabbing the center vertical shaft with your hand. As you do so, the disk will fall.
- ⑤ You can also cause the disk to rise by spinning the center vertical shaft in the same direction as the precession.

Notes:

Experiment 4: Nutations - Demonstration

EQUIPMENT NEEDED

- Gyroscope (ME-8960)

Purpose

Three different types of nutation are shown.

Procedure

- ① Adjust the counterweights until the gyroscope is balanced.
- ② Put the add-on mass on the end of the shaft.
- ③ Spin the disk and release the gyroscope from rest at an angle of about 30° . See Figure 4.1.

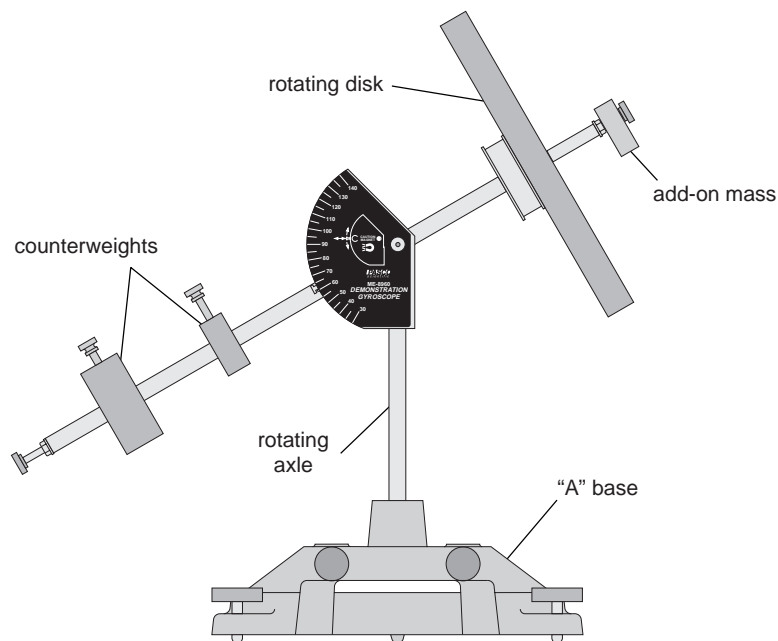

Figure 4.1: Release Position of Gyro

- ④ The resulting nutation will look like pattern (A) in Figure 4.2.
- ⑤ Stop the precession and spin the disk again. Release the gyroscope from the same angle but give it an initial push in the direction of precession. The resulting nutation will look like pattern (B) in Figure 4.2.
- ⑥ Stop the precession and spin the disk again. Release the gyroscope from the same angle but give it an initial push in the direction opposite to the precession. The resulting nutation will look like pattern (C) in Figure 4.2.
- ⑦ Spin the disk at a different speed and check the effect this has on the speed of the nutation.
- ⑧ Release the disk from a different angle and check the effect this has on the nutation.

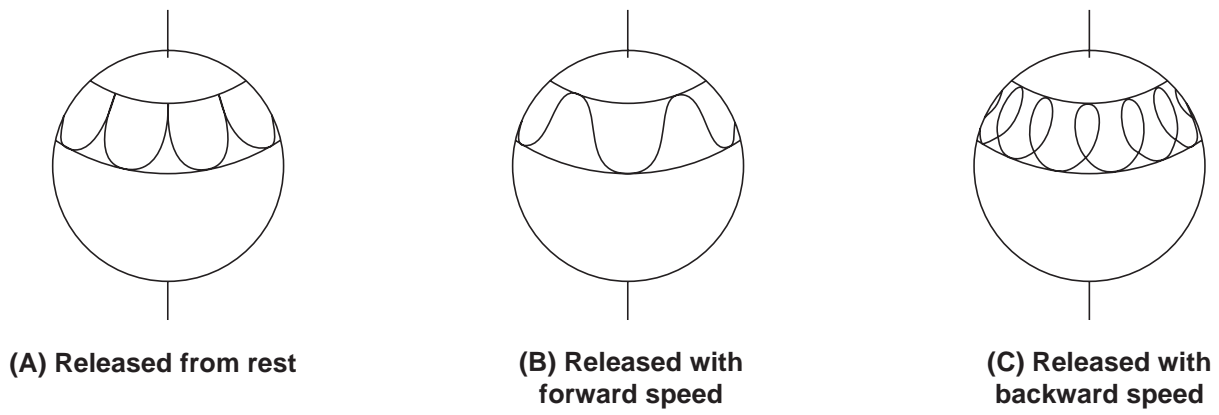

Figure 4.2: Patterns of Resultant Nutations

Technical Support

Feed-Back

If you have any comments about this product or this manual please let us know. If you have any suggestions on alternate experiments or find a problem in the manual please tell us. PASCO appreciates any customer feed-back. Your input helps us evaluate and improve our product.

To Reach PASCO

For Technical Support call us at 1-800-772-8700 (toll-free within the U.S.) or (916) 786-3800.

Contacting Technical Support

Before you call the PASCO Technical Support staff it would be helpful to prepare the following information:

- If your problem is computer/software related, note:

Title and Revision Date of software.

Type of Computer (Make, Model, Speed).

Type of external Cables/Peripherals.

- If your problem is with the PASCO apparatus, note:

Title and Model number (usually listed on the label).

Approximate age of apparatus.

A detailed description of the problem/sequence of events. (In case you can't call PASCO right away, you won't lose valuable data.)

If possible, have the apparatus within reach when calling. This makes descriptions of individual parts much easier.

- If your problem relates to the instruction manual, note:

Part number and Revision (listed by month and year on the front cover).

Have the manual at hand to discuss your questions.

