

Curved PATrack

ME-6841

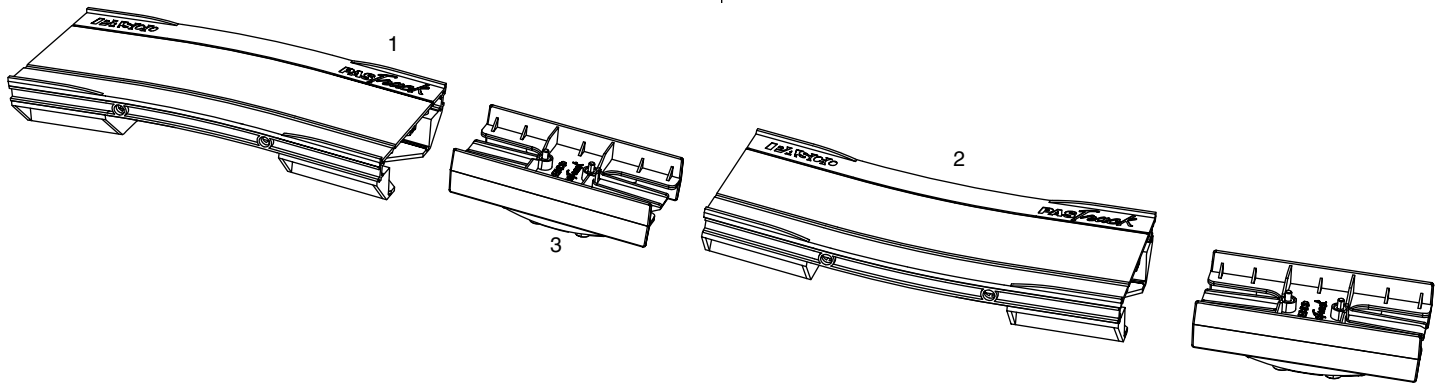

Included Equipment

1. Concave-down section
2. Concave-up section
3. Connectors (2 pieces)

Other Equipment Required

- Straight PATrack (PASCO part ME-6960, which consists of two straight sections)
- Rods, stands, and clamps for supporting elevated track sections (see options on page 2)
- PASCO Dynamics Cart (ME-6950, ME-6951, ME-9430, or ME-9454)

Quick Start

1. Use connector pieces to join the curved sections (part of ME-6841) and straight sections (part of ME-6960) in any order (see examples in figures 6 through 9).

Ensure that the wide and narrow grooves match from one section to the next (see Figure 2).

2. Tighten the screws on the connectors.
3. Use rods, stands, and clamps to support the elevated straight sections (see figures 3 through 5).

Introduction

PASCO model ME-6841 consists of two curved sections that can be joined with straight PATrack sections to form a single track with different levels. The combined track can be used to study how a change in height affects the motion of a cart. The track is compatible with all PASCO dynamics carts (including plastic PAScars and classic aluminum carts) and other dynamics system accessories.

Parts of the Curved PATrack

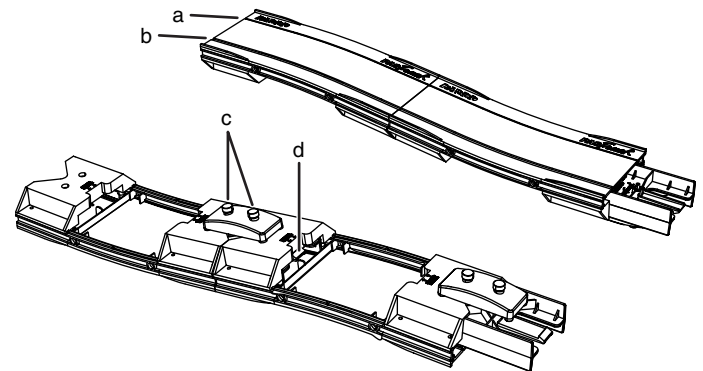

Figure 1

- a. Narrow groove
- b. Wide groove
- c. Connector screws
- d. Release tab

Assembly

1. Slide a connector piece into a track section. Push it hard until you hear it snap.
2. Slide the next track section onto the connector piece. Push it until it snaps.

NOTE: Every track section has one narrow groove and one wide groove. Orient the pieces so that the grooves match from one section to the next (see Figure 2).

3. Turn the track upside down and tighten the screws on the connector (part c in Figure 1).
4. Repeat steps 2 through 3 until all sections are assembled as desired.

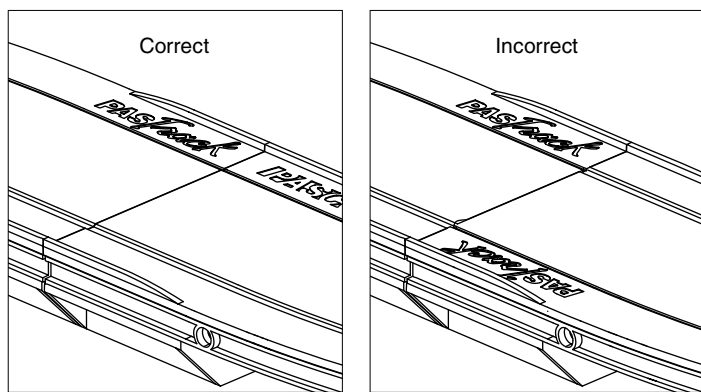

Figure 2: Ensure that the wide and narrow grooves match from one section to the next.

Disassembly

1. Loosen the connector screws.
2. Press and hold the release tabs on the bottom of the track (part d in Figure 1).
3. Pull the track sections apart.

Options for Supporting Elevated Track Sections

The elevated straight sections of the assembled track can be supported using one of the methods illustrated in figures 3, 4, and 5. The number of support points needed depends on the length of the track. In most cases, two are sufficient.

Pivot Clamp Method Attach a Pivot Clamp (ME-9810) to the T-slot on the side of a straight section (Figure 3). Secure the Pivot Clamp at the desired height on a vertical rod. The vertical rod can be supported by a table clamp (such as ME-9376B) or by a rod base (such as ME-8976).

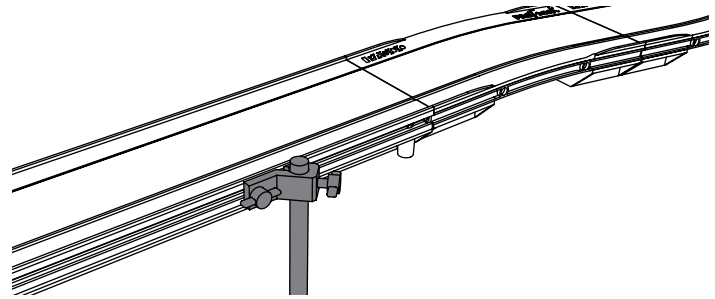

Figure 3: Pivot Clamp

Horizontal Rod Method Secure a rod (such as SA-9242) in the built-in rod clamp of the straight section (Figure 4). Use a right-angle clamp (such as SE-9442) to secure this rod on a vertical rod at the desired height.

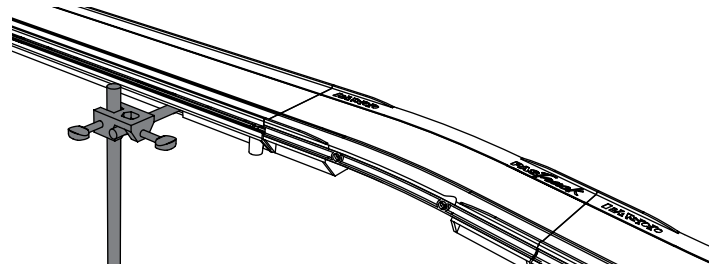

Figure 4: Horizontal Rod

Block Method Place blocks, or other objects such as books or lab jacks, under the feet of the straight section (Figure 5).

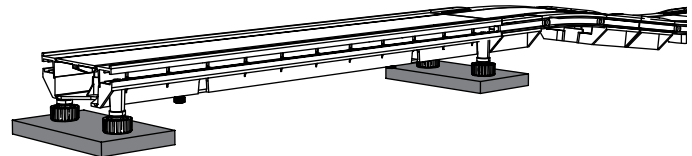

Figure 5: Block

Configuration Examples

Small Height Change



Figure 6: Small height change using both curved sections and two straight sections

In this configuration, the higher level is about 34 mm above the lower level. Use photogates or motions sensors to measure the velocity of a cart at both levels. Calculate and compare the changes in potential energy and kinetic energy.

The track is slightly flexible so that the higher level can be made slightly inclined. This makes it possible to release the cart from the top level without pushing it.

With this small height change, it is possible to launch a plastic PAScar from the lower level to the higher level using the cart's built-in plunger.

Larger Height Change



Figure 7: Larger height change using both curved sections and three straight sections

For a larger height change, add one or more straight sections between the curved sections. In the configuration shown in Figure 7, the height change is about 10 cm. The flexibility of the track allows the height to be varied slightly.

Ramp



Figure 8: Ramp using the concave-up curved section and two straight sections

In this configuration, the angle of the inclined section is about 8° . The flexibility of the track allows the angle to be varied slightly.

Release a cart from various points on the inclined section and use photogates or a motion sensor to measure the velocity on the level section.

Oscillator



Figure 9: Oscillator using the concave-up curved section and two straight sections

The oscillator uses the same combination of sections as the ramp, but both straight sections are inclined. A cart released from one end will oscillate several times before coming to rest at the center.

Technical Support

For assistance with any PASCO product, contact PASCO at:

Address: PASCO scientific
10101 Foothills Blvd.
Roseville, CA 95747-7100

Phone: 916-786-3800 (worldwide)
800-772-8700 (U.S.)

Fax: (916) 786-7565

Web: www.pasco.com

Email: support@pasco.com

For more information about the Curved PASTrack and the latest revision of this Instruction Sheet, visit:

www.pasco.com/go?ME-6841

Limited Warranty For a description of the product warranty, see the PASCO catalog. **Copyright** The PASCO scientific 012-10515A *Curved PASTrack Instruction Sheet* is copyrighted with all rights reserved. Permission is granted to non-profit educational institutions for reproduction of any part of this manual, providing the reproductions are used only in their laboratories and classrooms, and are not sold for profit. Reproduction under any other circumstances, without the written consent of PASCO scientific, is prohibited. **Trademarks** PASCO and PASCO scientific are trademarks or registered trademarks of PASCO scientific, in the United States and/or in other countries. All other brands, products, or service names are or may be trademarks or service marks of, and are used to identify, products or services of, their respective owners. For more information visit www.pasco.com/legal.