

**Instruction Sheet
for the PASCO
Model WA-9607**

Chladni Plates Kit

Typical Pattern
Square Chladni Plate

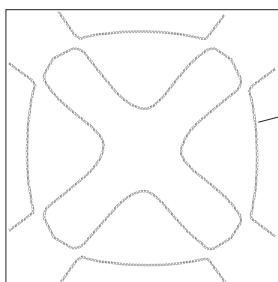

Typical Pattern
Circular Chladni Plate

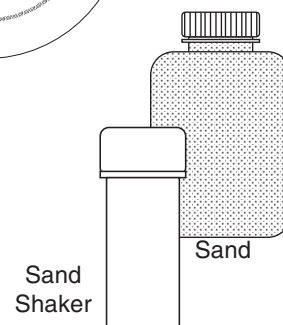
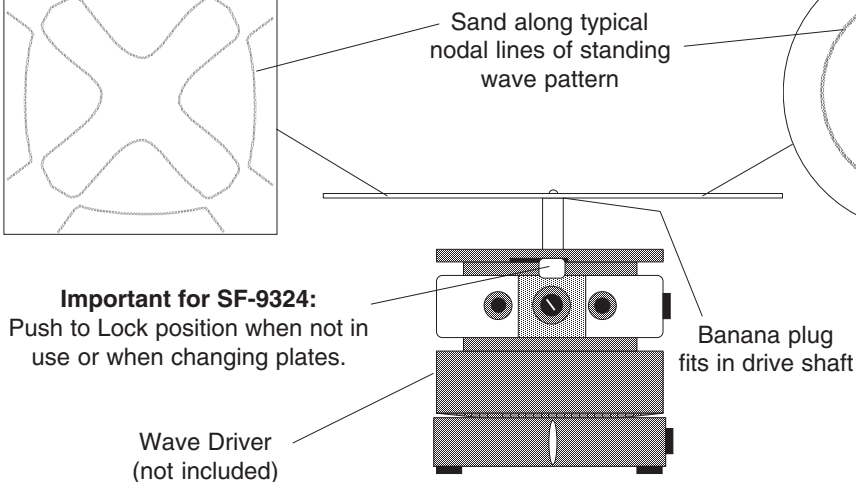
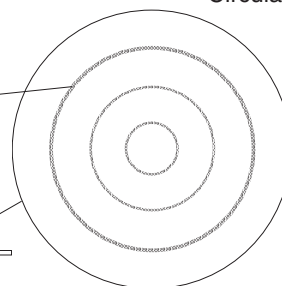

Introduction

A string vibrating at a resonant frequency develops a standing wave pattern consisting of regularly spaced nodes (points on the string that do not vibrate) and antinodes (points where the amplitude of vibration is a maximum). More interesting standing wave patterns are created with vibrations in media that support wave propagation in two dimensions, such as a metal plate or a drum head.

In the early nineteenth century, Ernst Chladni (pronounced Klädne) developed a technique for investigating two dimensional wave patterns. Sand is sprinkled onto a plate, and a violin bow is used to vibrate the plate. The sand comes to rest on the nodal lines, where no vibration occurs. Sand that is not resting on a nodal line gets bounced around until it finally lands on a nodal line and comes to rest.

When used with the PASCO Model WA-9753 Wave Driver II or SF-9324 Mechanical Wave Driver, the Chladni Plates Kit improves on Chladni's original method, allowing you to produce steady plate vibrations at any desired frequency. The illustrations at the top of the page show examples of the nodal patterns that can be created.

Equipment

The Model WA-9607 Chladni Plates Kit includes:

- Square Chladni Plate (24 cm sides)
- Circular Chladni Plate (24 cm diameter)
- Sand, extra fine (1 kg)
- Sand Shaker

⑤ NOTE: The Chladni Plates Kit is designed to be used with the Mechanical Wave Driver (SF-9324). The banana plug connectors attached to the plates connect directly with the drive shaft.

⑤ IMPORTANT: Always lock the drive shaft of the SF-9324 before attaching or removing the plates.

To Use the Chladni Plates

- ④ Connect the Chladni plate to the drive shaft as illustrated on the previous page. The banana plug mates directly with the hole in the drive shaft.
- ③ Sprinkle sand on top of the plate.
Unlock the drive shaft of the Wave Driver.
- ⇒ Connect the Wave Driver to your function generator/amplifier (such as PASCO Model PI-8127 Digital Function Generator). Vibrate the plate over a range of frequencies from about 100 Hz up to 5 kHz. As you slowly vary the frequency of vibration, you will discover a variety of standing wave patterns. (Don't change the frequency too fast—the resonances are very sharp and you might miss some.) Adjust the amplitude and the amount of sand as necessary to get clear patterns.
- ⑨ An interesting experiment is to hold an edge of the plate to determine the effect on the resonant frequencies and patterns. You can induce asymmetric standing wave patterns in the round plate by unscrewing the banana plug and connecting it to the off-center hole in the plate.

For further investigations, you may want to create your own Chladni plates. We recommend you cut them from aluminum sheets (approx. 0.035"), but you might find it interesting to experiment with other materials.

Limited Warranty

PASCO scientific warrants this product to be free from defects in materials and workmanship for a period of one year from the date of shipment to the customer. PASCO will repair or replace, at its option, any part of the product which is deemed to be defective in material or workmanship. This warranty does not cover damage to the product caused by abuse or improper use. Determination of whether a product failure is the result of a manufacturing defect or improper use by the customer shall be made solely by PASCO scientific. Responsibility for the return of equipment for warranty repair belongs to the customer. Equipment must be properly packed to prevent damage and shipped postage or freight prepaid. (Damage caused by improper packing of the equipment for return shipment will not be covered by the warranty.) Shipping costs for returning the equipment, after repair, will be paid by PASCO scientific.

To Reach PASCO

For Technical Support call us at 1-800-772-8700 (toll-free within the U.S.) or (916) 786-3800.

email: support@PASCO.com

Tech support fax: (916) 786-7565