

**Instruction Sheet
for the PASCO
Model CI-6689A**

CHAOS ACCESSORY

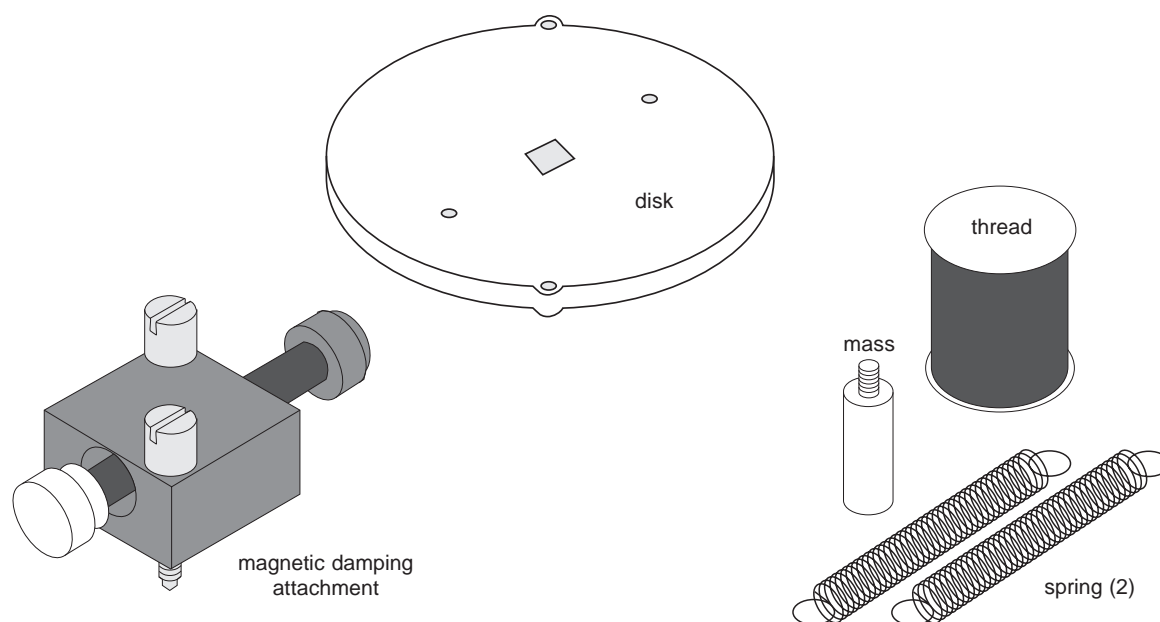

Introduction

The PASCO CI-6689A Chaos Accessory is designed for use with the PASCO CI-6538 Rotary Motion Sensor (RMS) or the PASCO CI-6625 Rotary Motion Sensor for ULI. It consists of an aluminum disk (identical to the one provided with the PASCO CI-6691 Mini-Rotational Accessory), a mass which attaches to the edge of the disk to form a physical pendulum, two springs for putting tension in the thread, and an adjustable-gap magnet which attaches to the side of the RMS to provide variable magnetic damping.

Please refer to the instruction manual supplied with the Rotary Motion Sensor for a detailed description of experiments using the Chaos Accessory.

Chaos Experiment

The purpose is to examine the different modes of oscillation of a damped driven physical pendulum caused by varying the driving amplitude, driving frequency, magnetic damping, and initial conditions.

Additional Equipment Required

- IDS Mount Accessory (CI-6692)

A mounting bracket for mounting the RMS to the PASCO Introductory Dynamics System tracks (1.2 meter ME-9435A or 2.2 meter ME-9458).

© 1996 PASCO scientific

This instruction sheet written by: Jon Hanks

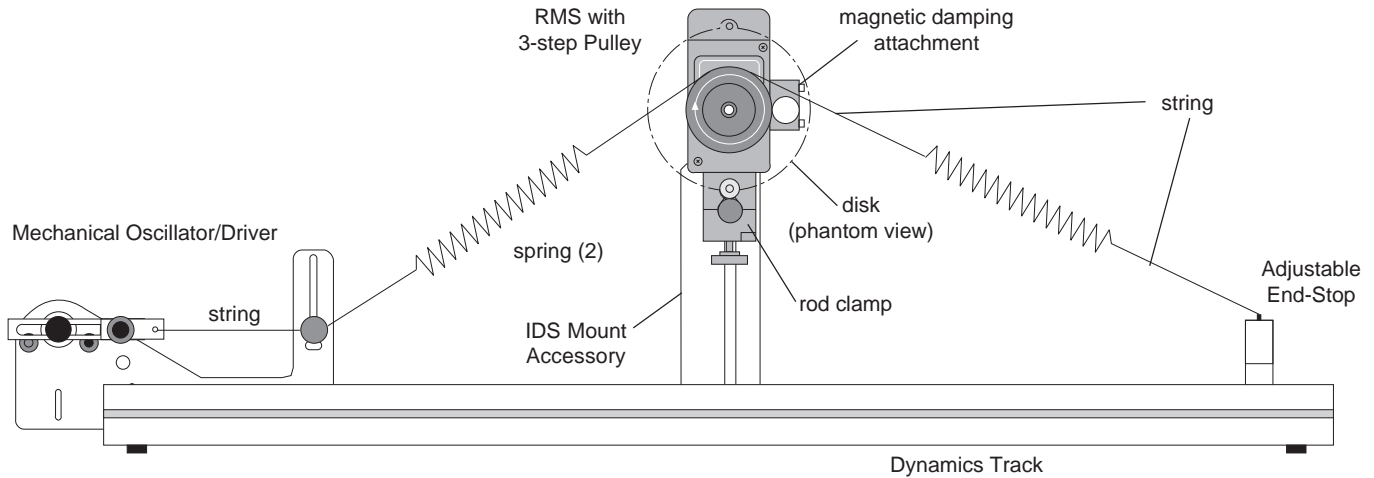

Chaos Experiment Setup

Damped Pendulum Experiment

The purpose is to show the motion of a magnetically damped physical pendulum.

Limited Warranty

PASCO scientific warrants this product to be free from defects in materials and workmanship for a period of one year from the date of shipment to the customer. PASCO will repair or replace, at its option, any part of the product

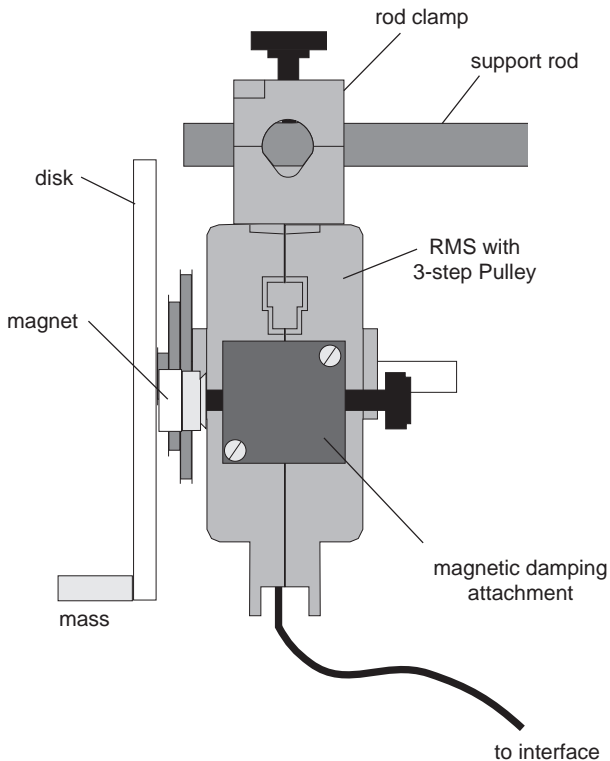

Damped Pendulum Experiment Setup

which is deemed to be defective in material or workmanship. This warranty does not cover damage to the product caused by abuse or improper use. Determination of whether a product failure is the result of a manufacturing defect or improper use by the customer shall be made solely by PASCO scientific. Responsibility for the return of equipment for warranty repair belongs to the customer. Equipment must be properly packed to prevent damage and shipped postage or freight prepaid. (Damage caused by improper packing of the equipment for return shipment will not be covered by the warranty.) Shipping costs for returning the equipment, after repair, will be paid by PASCO scientific.

To Reach PASCO

For Technical Support call us at 1-800-772-8700 (toll-free within the U.S.) or (916) 786-3800.

email: techsupp@PASCO.com

Tech support fax: (916) 786-3292

Web: <http://www.pasco.com>