

Ballistic Pendulum Accessory

ME-9892

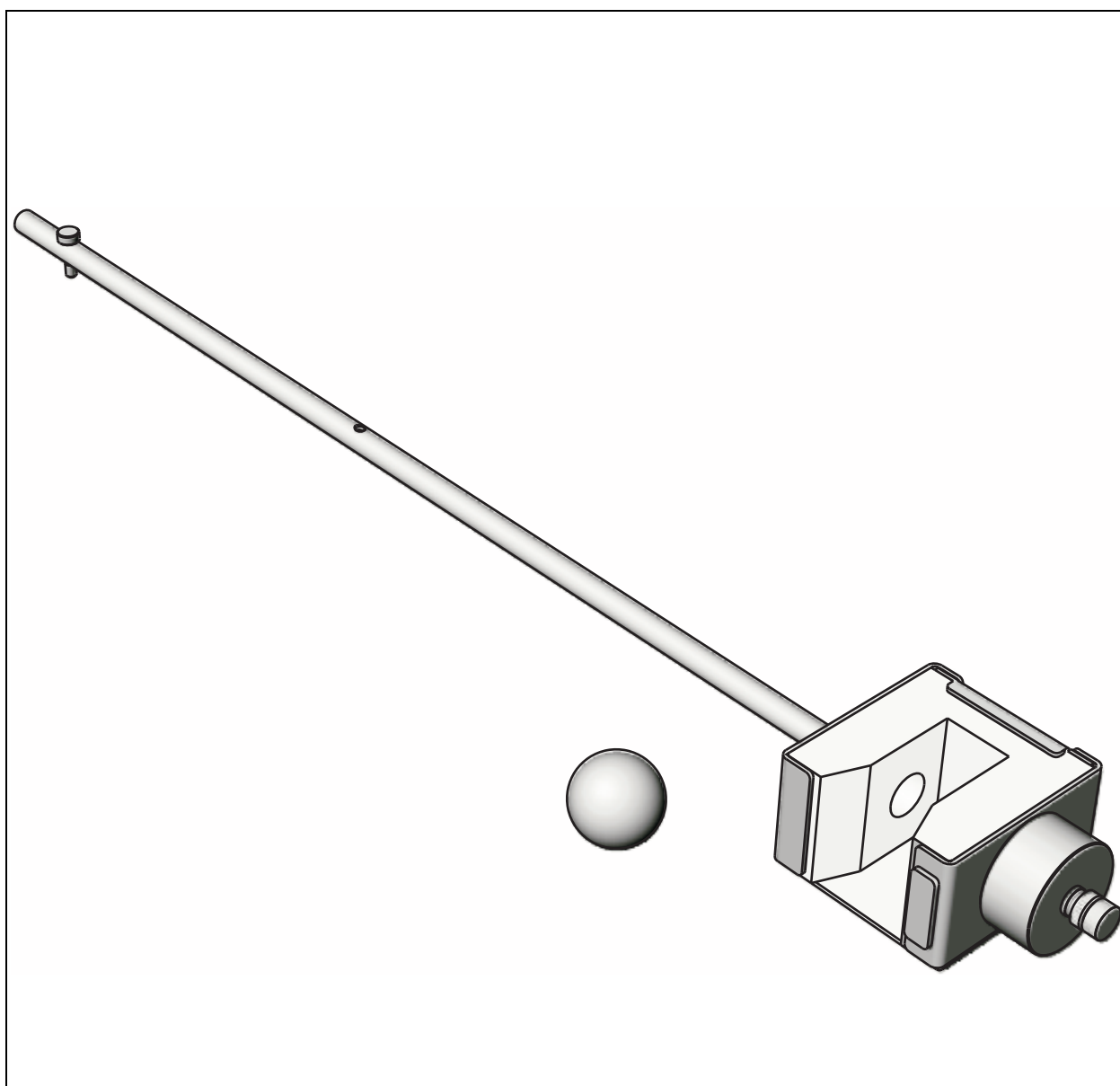

Introduction 4

Equipment Set-up 4

 Assemble the Apparatus, 4

 Load the Launcher, 5

 Prepare the Sensor, 6

 Test Fire, 6

Foam Insert Replacement 6

Experiment 1: Ballistic Pendulum 7

 Theory, 7

 Experiment Set-up, 7

 Procedure, 7

 Analysis, 9

 Question, 9

 Further Study, 9

Experiment 2: Conservation of Momentum and Energy 10

 Background, 10

 Part 1: Measure Launch Velocity, 10

 Part 2: Record Ballistic Pendulum Data, 10

 Part 3: Determine Rotational Inertia of Pendulum-ball System, 11

 Analysis, 13

 Questions, 13

 Further Study I: Different Launch Speeds, 14

 Further Study II: Different Projectile Mass, 14

 Further Study III: Different Center of Mass, 14

 Further Study IV: Elastic Collision, 14

 Further Study V: Alternative Determination of Rotational Inertia, 15

 Further Study VI: Horizontal Collision, 16

Technical Support 17

Ballistic Pendulum Accessory

ME-9892

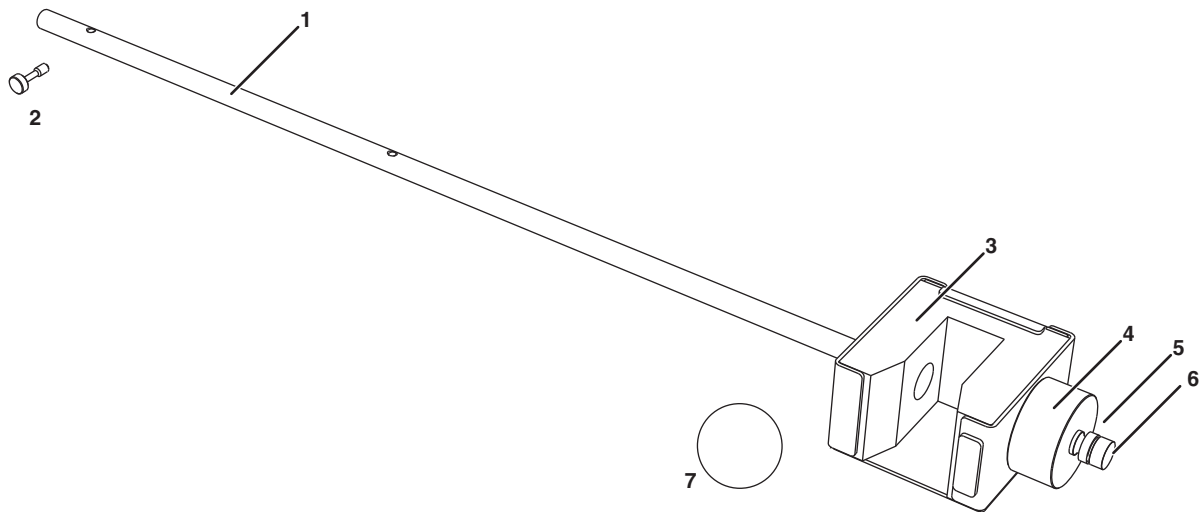

Included Equipment	Part Number	Optional Equipment	Part Number
1. Catcher and pendulum rod	ME-9892	Photogates (qty. 2) ²	ME-9498A <i>or similar</i>
2. Pendulum attachment screw	613-076	Digital Adapter ^{1, 2}	PS-2159
3. Replaceable foam insert	648-09757	Photogate Mounting Bracket ²	ME-6821
4. Ballast mass	648-06511	Super Pulley with Clamp ²	ME-9448B
5. Ballast lock nut	614-029	Hanging mass ²	ME-8979 <i>or similar</i>
6. Ballast fastening screw	617-027	Mini Rotational Accessory ³	CI-6691
7. Steel ball	ME-9864 (4-pack)	Spherical Mass Set ⁴	ME-8968
Required Equipment		Additional three-step pulley ⁵	CI-6693
Short Range Launcher	ME-6800	45 cm mounting rod ⁵	ME-8736 <i>or similar</i>
PASPORT Rotary Motion Sensor with three-step pulley ¹	PS-2120	Multi clamp ⁵	ME-9507 <i>or similar</i>
Table Clamp	ME-9472 <i>or similar</i>		
90 cm mounting rod	ME-8738 <i>or similar</i>		
C-clamp	SE-7286 <i>or similar</i>		

¹Sensor requires a PASPORT interface.

²For measuring launch velocity and rotational inertial. See Experiment 2.

³Required for Experiment 2

⁴For Experiment 2, Further Study II: Different Projectile Mass

Introduction

Use the Ballistic Pendulum Accessory in combination with a Short Range Launcher and Rotary Motion Sensor (RMS) to measure the velocity of a steel ball and study rotational collisions. The launcher shoots the ball into the Ballistic Pendulum Accessory. The RMS measures the resulting angular displacement and velocity of the pendulum. The pendulum can be configured to catch the ball or allow the ball to bounce off. With the addition of the Mini Rotational Accessory, the apparatus can be configured as a physical pendulum or rotational system with adjustable moment of inertia.

This manual includes set-up instructions and experiment instructions.

Equipment Set-up

Assemble the Apparatus

1. Set up the launcher, C-clamp, table clamp, mounting rod, and RMS as shown in Figure 1. The exact position of the RMS is not important yet. Note that the side of the RMS *without* the model number on the label is facing you. (If the RMS is mounted the other way, it will measure negative displacement.)

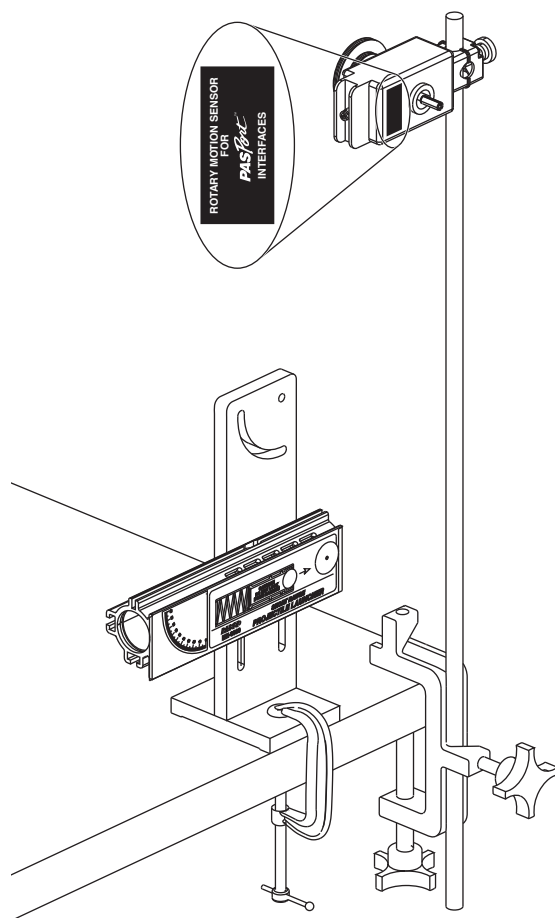

Figure 1: Launcher and RMS mounted on rod

2. Slide the three-step pulley onto the RMS shaft with the largest pulley out as shown in Figure 2.

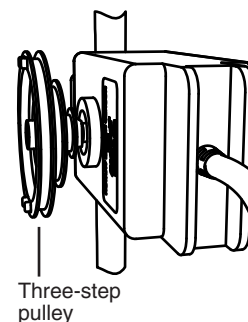

Figure 2: Three-step pulley on RMS

3. Select one of the holes on the pendulum rod: either the center hole or the end hole. Also select a side of the pendulum: either the catcher or the bumper. Thread the attachment screw into the hole as shown in Figure 3. Screw it all the way in so it is loosely captured.
4. Thread the screw into the end of the RMS shaft. Align the pendulum rod with the tabs on the pulley as shown in Figure 4. Tighten the screw.

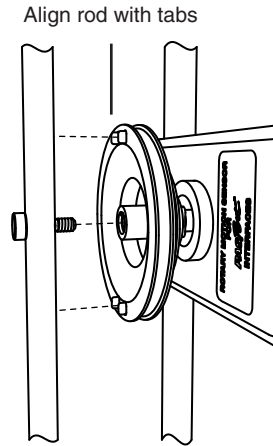

Figure 4: Attaching pendulum to RMS

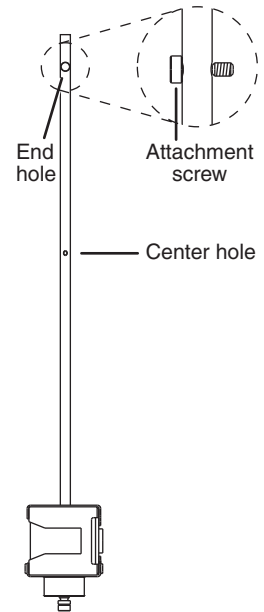

Figure 3: Attachment screw loosely captured in center hole

5. Adjust the position of the RMS so the pendulum is aligned with the launcher as shown in Figure 5. Leave a 2.5 cm gap between the launcher and the pendulum.

Load the Launcher

1. Swing the pendulum out of the way as shown in Figure 6.
2. Place the steel ball in the end of the barrel.

Caution: Use extra caution when using the launcher with a steel ball. Do not look down the barrel. Do not leave the launcher loaded and unattended.

3. Use the pushrod included with the launcher to push the ball down the barrel until the trigger catches in the first, second, or third position (for a slow, medium, or fast launch).

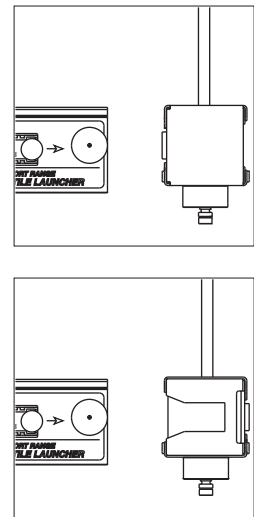

Figure 5: Pendulum aligned with launcher, bumper side (top) and catcher side (bottom)

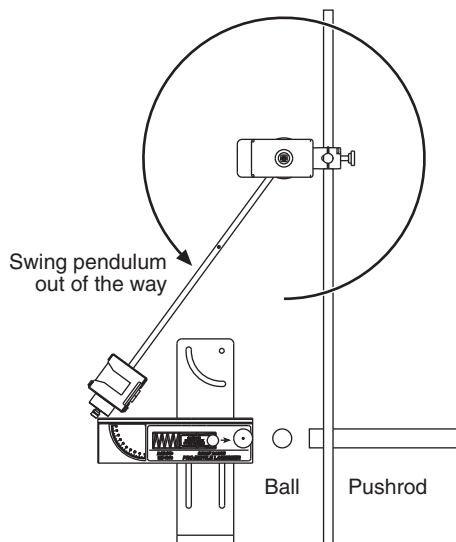

Figure 6: Loading the launcher

- Return pendulum to its normal hanging position.

Prepare the Sensor

- Connect the RMS to a PASPORT interface. If you will be using a computer, connect the interface to it and start your data collection software.
- Set the sampling rate of the RMS to 40 Hz.
- Prepare a graph to show angular position versus time.

For detailed instructions, refer to the documentation that came with your interface or press F1 to launch the software's on-line help.

Test Fire

- Start data recording.
- Pull the trigger of the launcher.
- Stop data collection.

Figure 7 shows typical data for an inelastic collision. If your data shows negative angular displacement, disassemble the RMS from the mounting rod and pendulum and remount it with the pendulum attached to the other end of the RMS shaft.

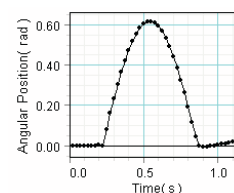

Figure 7: Typical data

Foam Insert Replacement

With age and repeated use, the foam catcher insert may lose elasticity. If the catcher does not reliably hold the ball, remove the foam insert and replace it with a new one. (Contact PASCO Teacher Support for a replacement foam insert, 648-09757).

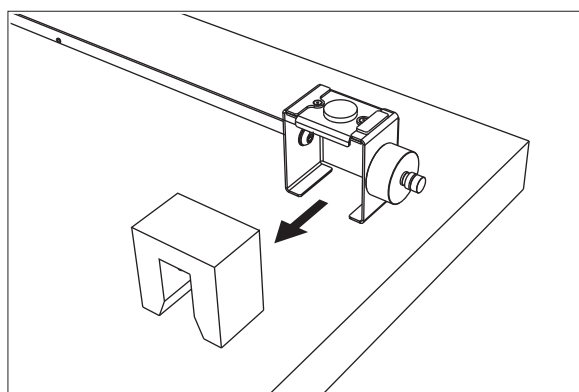

Figure 8: Removable foam insert

Experiment 1: Ballistic Pendulum

Theory

The ballistic pendulum has historically been used to measure the launch velocity of a high speed projectile. In this experiment, a projectile launcher fires a steel ball (of mass m_{ball}) at a launch velocity, v_0 . The ball is caught by a pendulum of mass m_{pend} . As the momentum of the ball is transferred to the catcher-ball system, the pendulum swings freely upwards, raising the center of mass of the system by a distance h .

The pendulum rod is hollow to keep its mass low, and most of the mass is concentrated at the end so that the entire system approximates a simple pendulum. During the collision of the ball with the catcher, the total momentum of the system is conserved. Thus the momentum of the ball just before the collision is equal to the momentum of the ball-catcher system immediately after the collision:

$$(eq. 1.1) \quad m_{\text{ball}}v_0 = MV$$

where V is the speed of the catcher-ball system just after the collision, and

$$(eq. 1.2) \quad M = m_{\text{ball}} + m_{\text{pend}}$$

During the collision, some of the ball's initial kinetic energy is converted into thermal energy. But *after* the collision, as the pendulum swings freely upwards, we can assume that energy is conserved and that all of the kinetic energy of the catcher-ball system is converted into the increase in gravitational potential energy.

$$(eq. 1.3) \quad \frac{1}{2}MV^2 = Mgh$$

where $g = 9.81 \text{ m/s}^2$, and the distance h is the vertical rise of the center of mass of the pendulum-ball system.

Combining equations 1.1 through 1.3 (eliminating V) yields

$$(eq. 1.4) \quad v_0 = \left(1 + \frac{m_{\text{pend}}}{m_{\text{ball}}}\right)\sqrt{2gh}$$

Experiment Set-up

1. Attach the ballast mass to the bottom of the catcher.
2. Set up the equipment and software as described on pages 4–6 with the pendulum rod attached to the RMS at the end hole and the catcher side of the pendulum facing the launcher.

Procedure

Record Data

1. Load the launcher and push the ball in to the third (fastest) position.
2. Start data collection.

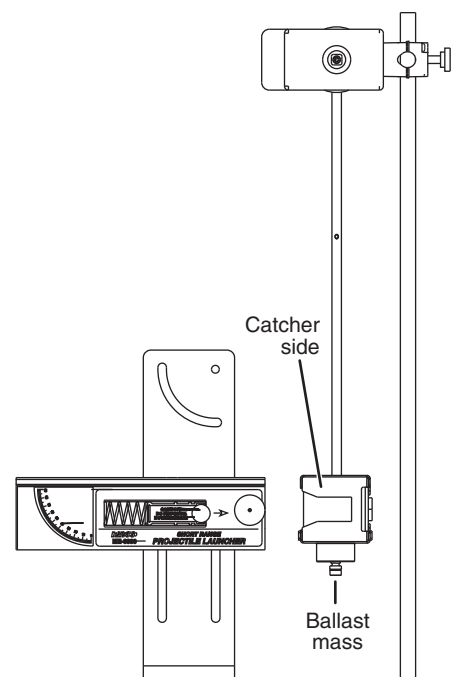

Figure 1.1: Set-up

- Launch the ball so that it is caught in pendulum.
- After the pendulum has swung out and back, stop data collection.
- Note the maximum angular displacement measured by the RMS. Record it in Table 1.1.
- Repeat steps 1 through 5 several times.
- Calculate the average maximum displacement, θ_{\max} .

Table 1.1: Maximum Angular Displacement

Trial	Angle
Trial 1	
Trial 2	
Trial 3	
Trial 4	
Trial 5	
Trial 6	
Avg:	$\theta_{\max} =$

Find the Mass and Center of Mass

- Fire the ball one more time (without recording data). Catch the pendulum near the top of its swing so it does not swing back and hit the launcher (this will prevent the ball from falling out or shifting).
- Remove the pendulum from the RMS.
- Remove the screw from the pendulum shaft.
- With the ball still in the catcher, place the pendulum at the edge of a table with the pendulum shaft perpendicular to the edge and the counterweight hanging over the edge. Push the pendulum out until it just barely balances on the edge of the table. The balance point is the center of mass. (See Figure 1.2.)

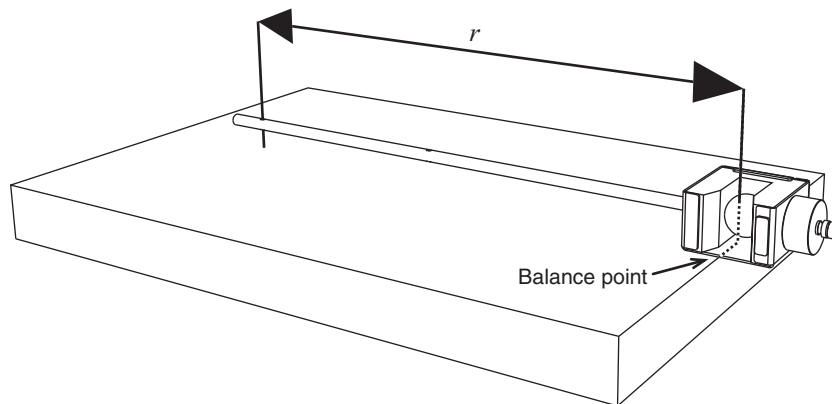
**Figure 1.2: Pendulum-ball system balanced on table edge**

- Measure the distance, r , from the center of rotation (where the pendulum was attached to the RMS) to the center of mass. $r =$ _____.
- Remove ball from the catcher.
- Measure the mass of the pendulum (without the ball). $m_{\text{pend}} =$ _____
- Measure the mass of the ball. $m_{\text{ball}} =$ _____

Analysis

1. Use your value of θ_{\max} , the distance r , and Equation 1.5 to calculate the maximum height (h) that the center of mass rises as the pendulum swings up (see Figure 1.3).

(eq. 1.5)
$$h = r(1 - \cos(\theta_{\max}))$$

$h =$ _____

2. Use your value of h and Equation 1.4 to calculate the launch velocity of the ball.

$v_0 =$ _____

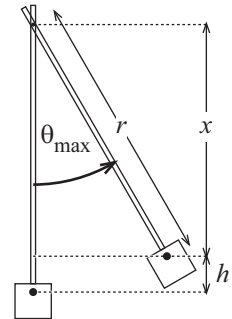

$$x = r \cos(\theta_{\max})$$

$$r = x + h$$

Figure 1.3:
Calculating h

Question

The theory for this experiment ignores the rotational inertia of the pendulum. Because the pendulum is not really a simple pendulum (a point mass on a massless rod), a systematic error is introduced. Does this simplistic analysis tend to give a launch velocity that is too high or too low? (See Experiment 3 for a more exact treatment.)

Further Study

Use two photogates to measure the launch velocity of the ball. Compare this value to the value you found using the ballistic pendulum.

Experiment 2: Conservation of Momentum and Energy

Background

In this experiment you will analyze the angular collision between a ball and a physical pendulum. You will compare the rotational momentum of the ball before the collision to the rotational momentum of the pendulum-ball system after the collision. Both rotational momenta are measured about the pendulum's pivot point.

You will also compare the kinetic energy of the ball before the collision, the kinetic energy of the pendulum-ball system just after the collision, and the maximum potential energy of the system after the collision.

The data-taking phase of this experiment has three parts. In Part 1 you will use photogates to measure the launch velocity of the ball. In Part 2 you will measure the maximum rotational velocity and angular displacement of the pendulum after the collision. In Part 3 you will measure the rotational inertia of the pendulum-ball system.

Part 1: Measure Launch Velocity

Set up the launcher with two photogates and a photogate bracket (see Figure 2.1). Measure the launch velocity (v_{launch}) of the ball on the fastest setting. Do several trials and use the average value.

If you will be doing the Advanced Study part of this experiment, also measure the launch velocity for the medium and slow settings.

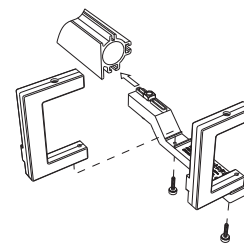

Figure 2.1: Launcher with photogates

Part 2: Record Ballistic Pendulum Data

Set-up

1. Set up the equipment and software as described on pages 4 through 6 with the pendulum rod attached to the RMS at the center hole and the catcher side of the pendulum facing the launcher. Do *not* attach the ballast mass to the bottom of the catcher.
2. Install one of the sliding masses from the Mini Rotational Accessory as a counterweight. Slide it onto the pendulum rod above the RMS attachment point. Adjust the position of the counterweight so the pendulum is perfectly balanced *without the ball*. If you release the pendulum in the horizontal position, it should not move. (See Figure 2.2.)

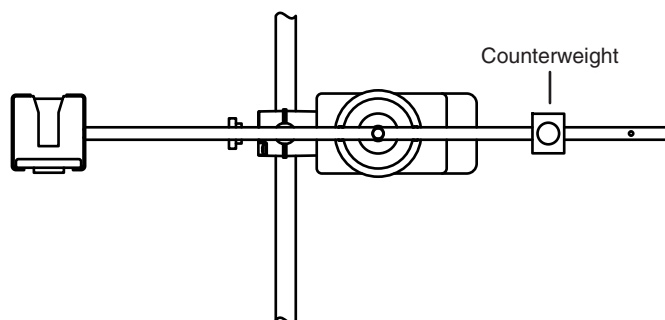

Figure 2.2: Pendulum balanced horizontally

3. Prepare a graph to display angular velocity versus time and position versus time.

Procedure

1. Load the launcher and push the ball in to the third (fastest) position.
2. Move the pendulum into the vertical position. If it does not stay that way by itself, hold it very lightly with one finger.
3. Start data collection.
4. Launch the ball so that it is caught by pendulum.
5. After the pendulum has swung out and back, stop data collection.
6. Note the maximum angular displacement measured by the RMS. Record it in Table 2.1
7. Record the initial angular velocity (just after the collision) in Table 2.1. Because this velocity occurs close to the collision, the RMS cannot measure it accurately. Instead, note the maximum *negative* velocity that occurs when the pendulum swings back toward the launcher (record it as a positive value). Though this might be slightly smaller than the actual initial velocity (due to friction), it is a more reliable measurement.
8. Repeat steps 1 through 7 several times.
9. Calculate the average maximum displacement (θ_{\max}) and the average initial velocity (ω_0).

Table 2.1: Angular Displacement and Velocity

Trial	Maximum Angle	Initial Angular Velocity
Trial 1		
Trial 2		
Trial 3		
Trial 4		
Trial 5		
Trial 6		
Average:	$\theta_{\max} =$	$\omega_0 =$

10. Measure the mass of the ball. $m_{\text{ball}} =$ _____
11. Fire the ball into the catcher one more time (without recording data). Catch the pendulum near the top of its swing so it does not swing back and hit the launcher (this will prevent the ball from falling out or shifting).
12. Measure the distance, ℓ , from the center of rotation (where the pendulum attaches to the RMS) to the center of ball. $\ell =$ _____

Part 3: Determine Rotational Inertia of Pendulum-ball System**Set-up**

1. Remove the RMS from the mounting rod. (Leave the pendulum attached to the RMS and leave the ball in the catcher.)

- Clamp the RMS on the mounting rod so that the pendulum can rotate in a horizontal plane (see Figure 2.3).

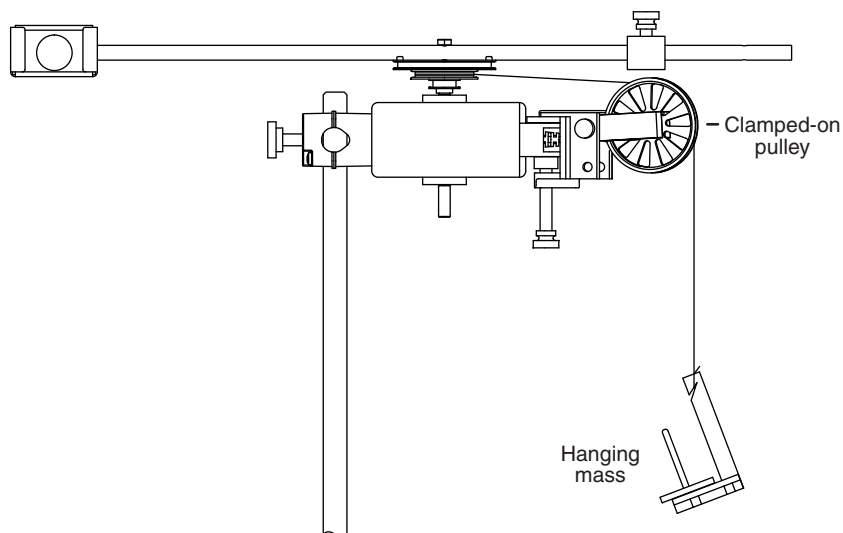

Figure 2.3: Setup for determining rotational inertia

- Clamp a pulley to the RMS and set up a string and hanging mass (approximately 20 g to 30 g) as shown in Figure 2.3. Wind the string a few times around the middle step of the three-step pulley. Adjust the angle and height of the clamped-on pulley so that the string will unwind and run over the pulley with as little friction as possible.

Procedure

- Start data collection.
- Release the hanging mass.
- After the string has unwound from the three-step pulley, stop data collection.
- Determine the angular acceleration of the pendulum (α) from the slope of the angular velocity versus time graph. $\alpha =$ _____
- Measure the radius of the middle step of the three-step pulley.
 $R_{\text{pulley}} =$ _____
- Measure the mass of the hanging mass. $m =$ _____
- Calculate the acceleration (a) of the hanging mass.

$$a = \alpha R_{\text{pulley}}$$

- Calculate the tension in the string (F_T). Since the hanging mass is accelerating, the string tension is not the weight of the mass. Writing Newton's 2nd Equation for the free-body diagram in Figure 2.4 yields:

$$ma = mg - F_T$$

where $g = 9.8 \text{ m/s}^2$.

$$F_T = \text{_____}$$

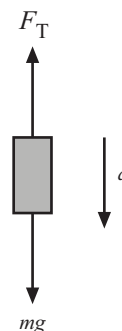

Figure 2.4: Free-body diagram of hanging mass

- Calculate the torque (τ) applied to the pulley by the string.

$$\tau = R_{\text{pulley}} F_T$$

- Calculate the rotation inertia (I) of the pendulum-ball system using the rotational form of Newton's 2nd Law:

$$\tau = I\alpha$$

$$I = \underline{\hspace{2cm}}$$

Analysis

- Calculate the initial angular momentum of the ball (L_{launch}) just before the collision. The angular momentum is calculated about the pendulum pivot.

$$L_{\text{launch}} = m_{\text{ball}} \ell v_{\text{launch}}$$

- Calculate the angular momentum of the ball-pendulum system (L_0) immediately after the collision.

$$L_0 = I\omega_0$$

- Calculate the kinetic energy of the ball (K_{launch}) before the collision.

$$K_{\text{launch}} = \frac{1}{2} m_{\text{ball}} v_0^2$$

- Calculate the kinetic energy of the ball-pendulum system (K_0) immediately after the collision.

$$K_0 = \frac{1}{2} I\omega_0^2$$

- Use the maximum angular displacement of the pendulum (θ_{max}) to calculate the change in height (h_{max}) of the ball. Refer to Figure 2.5.

- Calculate the gain in potential energy of the ball (ΔU_{ball}).

$$\Delta U_{\text{ball}} = m_{\text{ball}} g h_{\text{max}}$$

Questions

- Why did you calculate the ball's rotational momentum rather than the linear momentum? Why did you calculate the rotational momentum around the pendulum pivot rather than the center of the ball?
- Compare the rotational momentum of the ball before the collision to the rotational momentum of the pendulum-ball system just after the collision. Was momentum conserved?

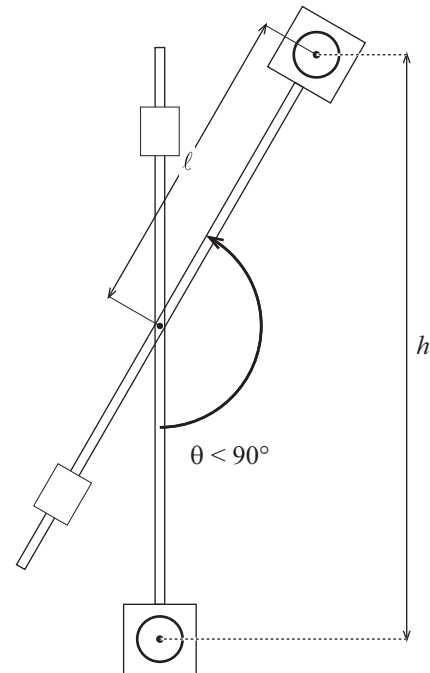
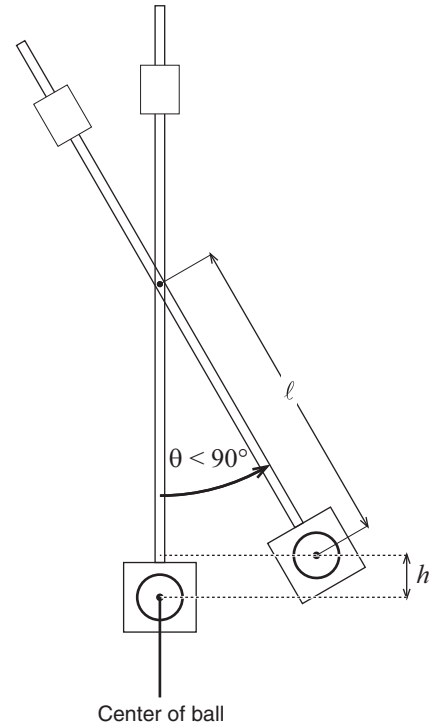

Figure 2.5: Calculating h

3. Compare the kinetic energy of the ball before the collision to the kinetic energy of the pendulum-ball system just after the collision. Was energy conserved in the collision?
4. What was the gain in potential energy of the pendulum (not including the ball)? What was the purpose of the counterweight?
5. Compare the kinetic energy of the pendulum-ball system just after the collision to the gain in potential energy of the ball. Was energy conserved as the pendulum swung after the collision?

Further Study I: Different Launch Speeds

Repeat the experiment for the slow and medium launch speeds. How does changing the launch speed affect how well momentum is conserved?

Look at the ratio of initial kinetic energy (of just the ball) to the kinetic energy of the pendulum-ball system (just after the collision). How does the launch speed of the ball affect this ratio?

Further Study II: Different Projectile Mass

Repeat the experiment with the lower-mass nylon ball (included with the launcher), or one of the balls from the Spherical Mass Set (ME-8968).

Further Study III: Different Center of Mass

Repeat the experiment without the counterweight. This time, you will need to find the center of mass of the pendulum-ball system (see Experiment 1). Measure the distance (r) from the axis of the RMS to the center of mass. When you calculate the potential energy gain of the system, the height (h) is the change in height of the center of mass of the system, not the ball.

Further Study IV: Elastic Collision

Examine the difference between catching the ball (completely inelastic collision) and allowing the ball to hit the bumper on the back of the catcher:

1. Place the counter-weight on the lower half of the pendulum rod between the middle hole and the catcher. Fasten the pendulum to the RMS using the middle hole with the bumper side towards the launcher. There should be a gap of a few centimeters between the end of the launcher and the bumper.
2. Launch the ball at its slowest speed. What happens to the ball when it hits the rubber bumper on the catcher? Adjust the position of the counter weight so that the ball drops *straight down* after the collision. If the counterweight is positioned too low, the ball bounces backwards. If the counterweight is too high, the ball still has some forward velocity. You want the horizontal velocity of the ball to be zero after the collision.
3. Perform the experiment as before and measure the maximum displacement (θ_{\max}) and initial angular velocity (ω_0) of the pendulum.
4. Measure the rotational inertia of the pendulum *without* the ball.

Find the pendulum's center of mass (without the ball). Measure the distance r from the axis of the RMS to the center of mass.

5. Perform the analysis for energy and momentum as before. What is the kinetic energy of the ball immediately after the collision? Why?

When you calculate the gain in potential energy, remember that h is the change in height of the center of mass of the pendulum, not including the ball.

Is this a perfectly elastic collision? What is the percentage of the kinetic energy lost (converted to thermal energy) during the collision?

6. Turn the pendulum around and repeat the experiment for catching the ball. (Do not change the position of the counterweight.) Note that both the rotational inertia and the center of mass (and thus the distance r) will change due to the ball being in the catcher.
7. For the two cases (ball hitting the bumper and ball being caught), compare the angular velocity of the pendulum just after the collision. Compare the maximum angular displacement for the two cases. Which type of collision causes the greater angular displacement? Why?

Further Study V: Alternative Determination of Rotational Inertia

In the procedure above, you found the rotational inertia of the pendulum by applying a known torque and measuring the resulting angular acceleration. An alternate method is to measure the period of oscillation.

For a physical pendulum of rotational inertia I and mass M , the theoretical period (for low-amplitude oscillations) is given by

$$T = 2\pi \sqrt{\frac{I}{Mgr}}$$

where r is the distance from the axis of rotation to the center of mass of the pendulum.

Measure the period of the pendulum (with a low amplitude) and calculate its rotational inertia. Compare this to the answer you got by applying a known torque.

Further Study VI: Horizontal Collision

Repeat the experiment with the apparatus in one of the configurations shown in Figure 2.6 and 2.7 using parts from the Mini Rotational Accessory (ME-8968) and a second three-step pulley. Use two sliding masses to balance the system with the ball in the catcher. Add the disk and (optionally) the ring to increase the moment of inertial.

After the collision, stop the catcher with your hand before it swings around and hits the back of the launcher.

In this variation of the experiment, there is no maximum displacement because the system would continue to rotate indefinitely if it were allowed to. What is the change in potential energy of the system?

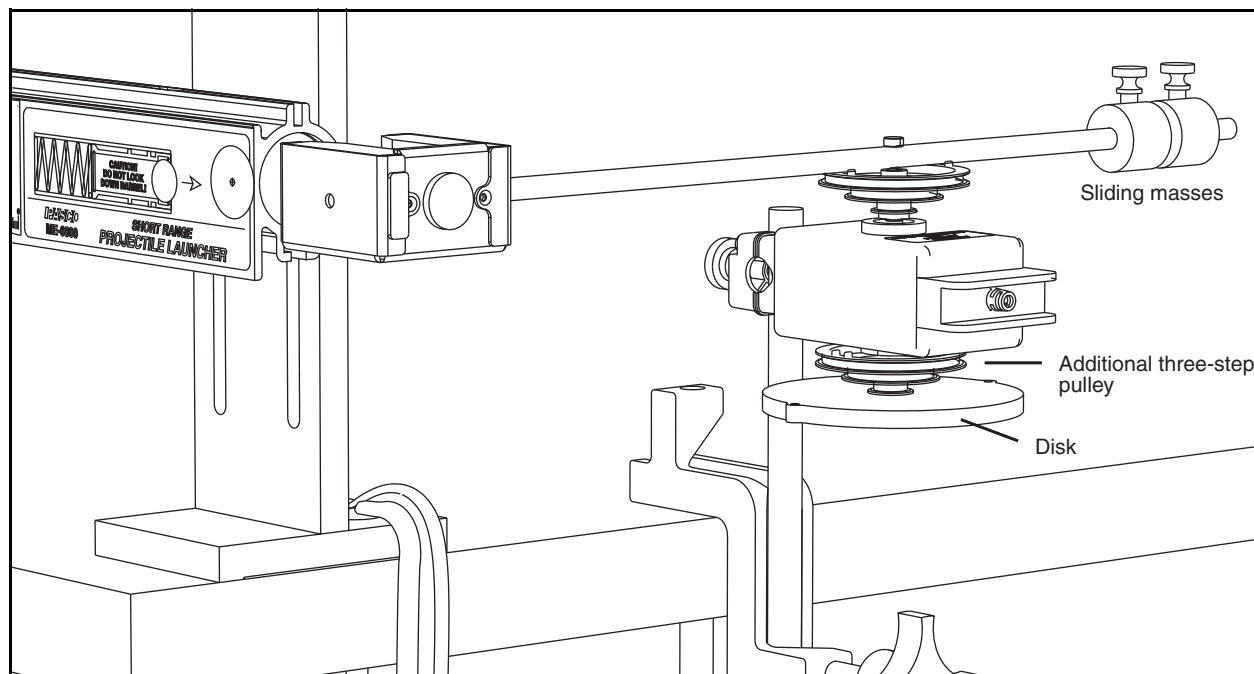

Figure 2.6: Setup for horizontal collision with disk only

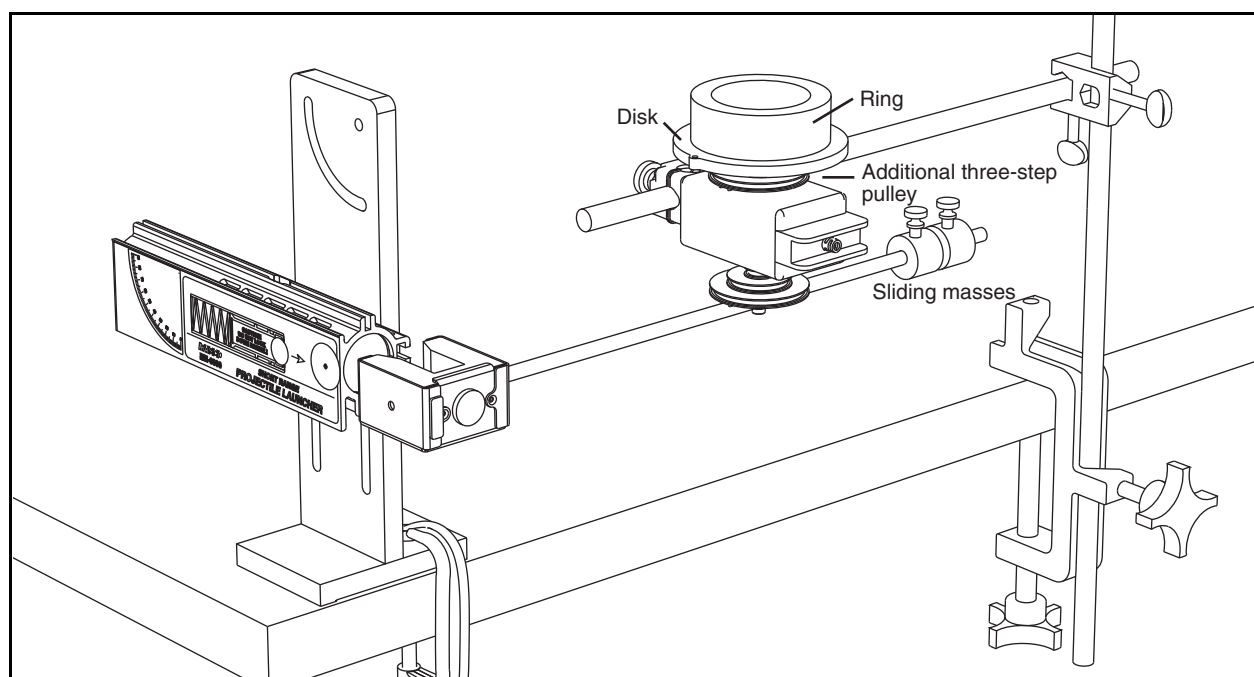

Figure 2.7: Setup for horizontal collision with disk and ring

Technical Support

For assistance with any PASCO product, contact PASCO at:

Address: PASCO scientific
10101 Foothills Blvd.
Roseville, CA 95747-7100

Phone: 916-462-8384 (worldwide)
877-373-0300 (U.S.)

Web: www.pasco.com

Email: support@pasco.com

Limited Warranty

For a description of the product warranty, see the PASCO catalog.

Copyright

The PASCO scientific *Ballistic Pendulum Accessory Instruction Manual* is copyrighted with all rights reserved. Permission is granted to non-profit educational institutions for reproduction of any part of this manual, providing the reproductions are used only in their laboratories and classrooms, and are not sold for profit. Reproduction under any other circumstances, without the written consent of PASCO scientific, is prohibited.

Trademarks

PASCO, PASCO scientific, PASCO Capstone, PASPORT, SPARK SLS, and Xplorer GLX are trademarks or registered trademarks of PASCO scientific, in the United States and/or in other countries. All other brands, products, or service names are or may be trademarks or service marks of, and are used to identify, products or services of, their respective owners. For more information visit www.pasco.com/legal.