

**Instruction Sheet
for the PASCO
Model CI-6690**

“A”-BASE ROTATIONAL ADAPTER

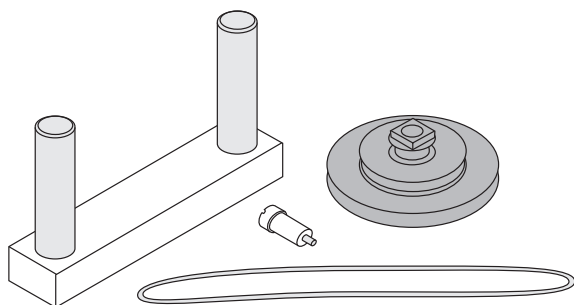

The PASCO CI-6690 “A”-Base Rotational Adapter is designed for use with the PASCO CI-6538 Rotary Motion Sensor (RMS) or the PASCO CI-6625 Rotary Motion Sensor for ULI. It is used to mount the RMS to the “A” base of the PASCO ME-8951 Rotating Platform or the PASCO ME-8960 Gyroscope. The Rotary Motion Sensor provides higher resolution than a Smart Pulley, and precession and nutation of the Gyroscope can be plotted since the RMS keeps track of direction of rotation. The adapter includes a mounting bracket, a shoulder screw, a drive belt (o-ring) and a 3-step Pulley. The drive belt links the 3-step Pulley mounted on the “A” base to the 3-step Pulley on the RMS. For a one-to-one correspondence, connect the two pulleys using the o-ring on the middle step of each pulley. Each revolution of the Rotating Platform or Gyroscope corresponds to one revolution of the RMS. If desired, a 5-to-1 ration can be attained by putting the o-ring on the top or bottom steps.

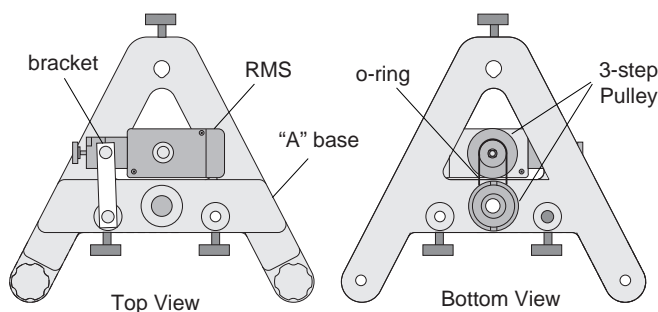

RMS Mounted on “A” base

The pulley attaches to the underside of the rotating shaft with the shoulder screw. Please note the pulley orientation as illustrated. The bracket connects to the “A” base of the Rotating Platform or the Gyroscope and to the RMS rod clamp.

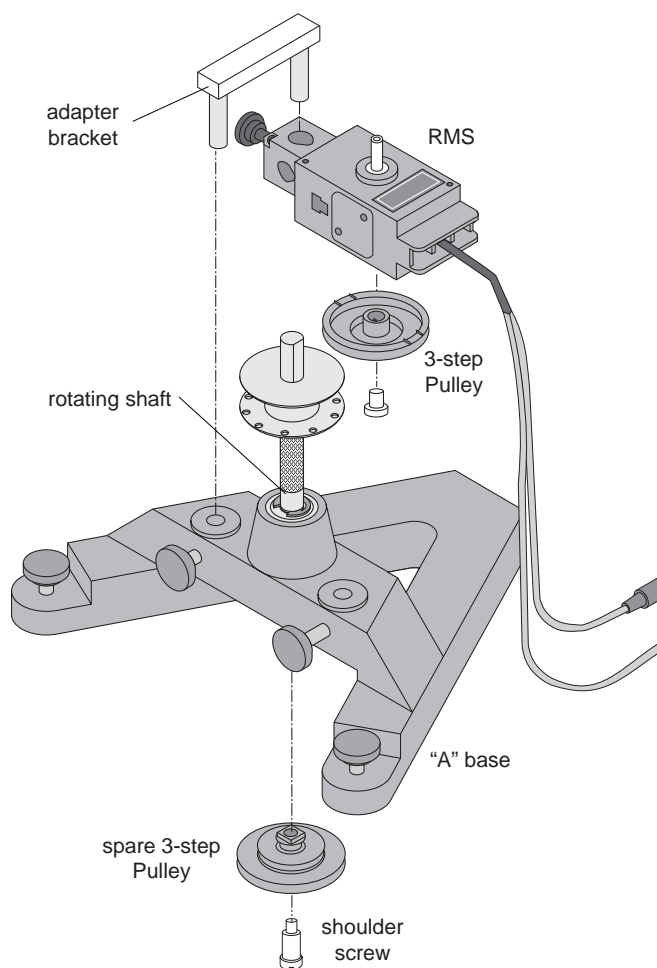

Assembling the RMS to the “A” Base

© 1996 PASCO scientific

This instruction sheet written by: Jon Hanks

Limited Warranty

PASCO scientific warrants this product to be free from defects in materials and workmanship for a period of one year from the date of shipment to the customer. PASCO will repair or replace, at its option, any part of the product which is deemed to be defective in material or workmanship. This warranty does not cover damage to the product caused by abuse or improper use. Determination of whether a product failure is the result of a manufacturing defect or improper use by the customer shall be made solely by PASCO scientific.

Responsibility for the return of equipment for warranty repair belongs to the customer. Equipment must be properly packed to prevent damage and shipped postage or freight prepaid. (Damage caused by improper packing of the equipment for return shipment will not be covered by the warranty.) Shipping costs for returning the equipment, after repair, will be paid by PASCO scientific.

To Reach PASCO

For Technical Support call us at 1-800-772-8700 (toll-free within the U.S.) or (916) 786-3800.

email: techsupp@PASCO.com

Tech support fax: (916) 786-3292

Web: <http://www.pasco.com>