

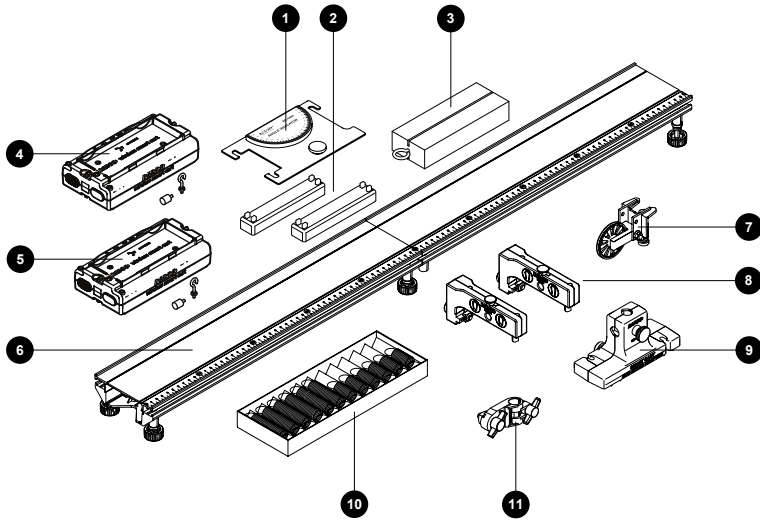

## Standard Smart Cart PATrack System

ME-5717A

### Product Description



### What's Included

- ❶ Angle Indicator  
ME-9495A
- ❷ Cart Mass (set of 2)  
ME-6757A
- ❸ Friction Block  
ME-9807
- ❹ Smart Cart (Red)  
ME-1240
- ❺ Smart Cart (Blue)  
ME-1241
- ❻ PATrack  
ME-6960
- ❼ Super Pulley with Clamp  
ME-9448B
- ❽ Track End Stop (2 Pack)  
ME-8971
- ❾ Smart Cart Rod Stand Adapter  
ME-1244
- ❿ IDS Spring Kit  
ME-8999
- ⓫ Track Rod Clamp  
ME-9836

### What's Required

- PASCO Capstone or SPARKvue Software

## Equipment Overview

This section provides a brief overview on how to use the equipment included with the dynamics system. For more detailed information, see the instruction manual included with each product.

### Smart Cart Features

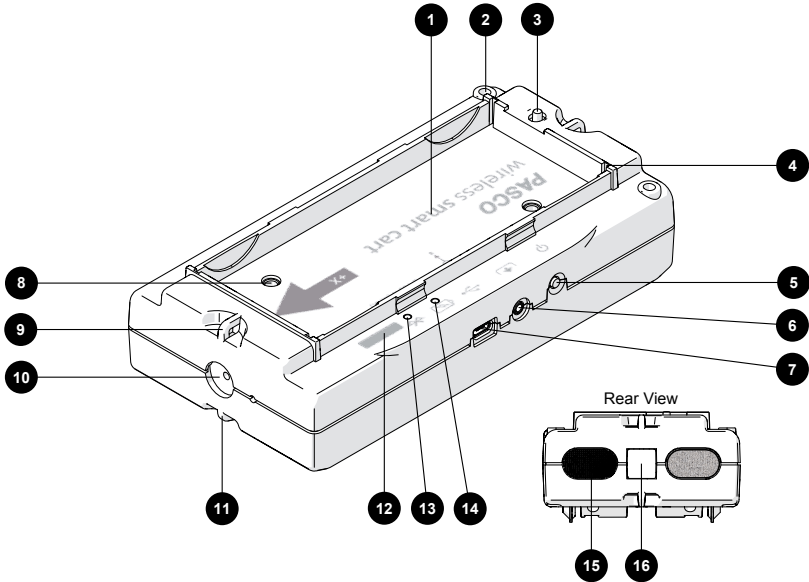

**1 Accessory Tray**

For placing accessories such as cart masses.

**2 Accessory Hole**

For attaching accessories such as the fan cart sail.

**3 Plunger Release**

Press to release the plunger at the rear of the cart.

**4 Accessory Tray Slot**

For attaching accessories such as a Cart Picket Fence (ME-9804) or Angle Indicator (ME-9495A).

**5 Power Button**

Press and hold for one second to power the cart on or off.

**6 Accessory Port**

For connecting Smart Cart accessories such as the Smart Fan (ME-1242), Smart Ballistic Cart (ME-1245), and Vector Display (ME-1246).

**7 USB Port**

For charging the battery by connecting the cart to a USB charger or the Smart Cart Charging Garage (ME-1243).

**8 Threaded Hole (M5)**

For securing accessories in the tray such as the Smart Cart Rod Stand Adapter (ME-1244).

**9 Upper Tie Point**

For attaching string or a spring to the cart. Springs included with the IDS Spring Kit (ME-8999) are designed to be used with carts.

**10 Force Sensor**

For attaching force sensor accessories such as the included hook, rubber bumper, and magnetic bumper. Additional accessories include spring bumpers and a clay cup in the Bumper Accessory Set (ME-9884).

**11 Lower Tie Point**

For attaching string that can run under an end stop, another cart, or a Motion Sensor

**12 Sensor ID**

Refer this ID when connecting the Smart Cart to software.

**13 Bluetooth Status Light**

Indicates the wireless connection status of the cart.

|             |              |
|-------------|--------------|
| Red blink   | Disconnected |
| Green blink | Connected    |

**14 Battery Status Light**

Indicates the battery charge level.

|              |               |
|--------------|---------------|
| Red blink    | Low charge    |
| Green solid  | Fully charged |
| Yellow solid | Charging      |

**15 Velcro® Fastener**

Allows cart to attach during collisions.

**16 Plunger**

Use to launch the cart or to push two carts apart with three different forces.

## PATrack Features

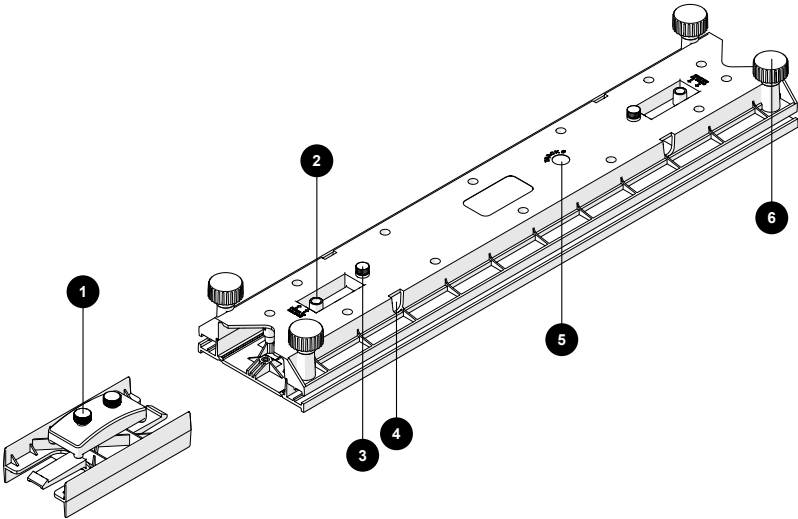

**1 Connector Screw**

For securing the connector to a track section.

**2 Release Tab**

Press down to release a connector from a track section.

**3 Rod Clamp Screw**

For securing a rod inserted into the rod clamp hole.

**4 Rod Clamp Hole**

For inserting a support rod to incline the track.

**5 Track Identifier**

Write a number in the provided space to organize a classroom set of tracks.

**6 Track foot**

Turn to level the track. Use the lock nut to secure the foot height.

## Attach an End Stop to a Dynamics Track

The Adjustable End Stop is designed to be mounted to the end of a dynamics track to stop dynamics carts from rolling off the end of the track.

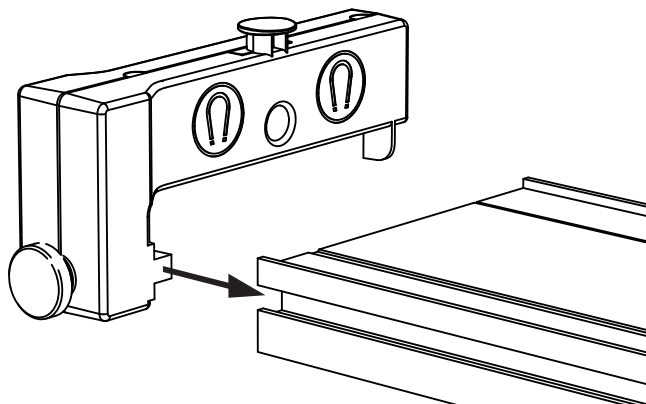

Figure 1. Installing the End Stop to a Dynamics Track.

1. Position the End Stop so that magnets on the End Stop face the track.
2. Insert the square nut and tab on the End Stop into the T-slot of the track.
3. Move the End Stop to the desired position then turn the thumbscrew to secure the end stop to the track.

## Mount a Smart Cart to a Rod

The Smart Cart Rod Stand Adapter allows the PASCO Smart Cart to be suspended from a rod to use its force sensor to measure forces. The adapter contains two holes that are perpendicular to each other that allows the Smart Cart to be mounted vertically or horizontally.

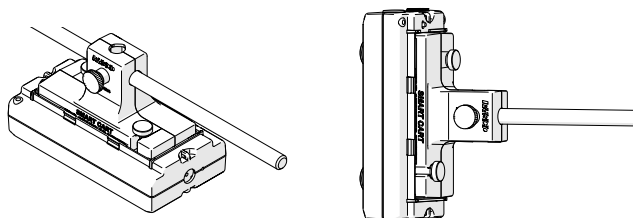
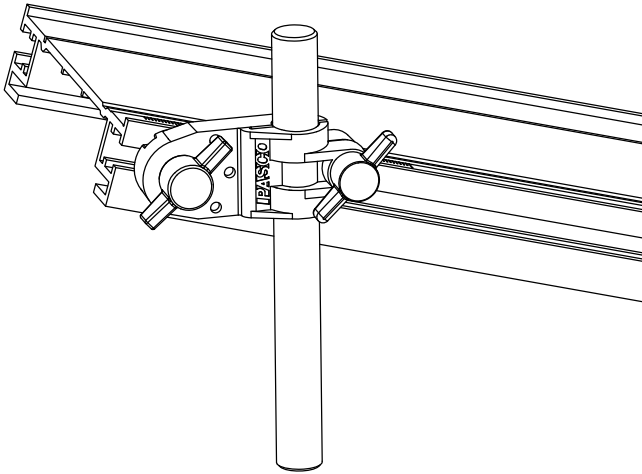

Figure 2. Two ways to mount the Smart Cart to a support rod using the Smart Cart Rod Stand Adapter.

## Attach the Track Rod Clamp to a Dynamics Track



*Figure 3. A Track Rod Clamp attached to a Dynamics Track and support rod.*

The Track Rod Clamp is used to elevate a PASCO Dynamics Track to create an incline. The clamp holds the track to a support rod. To attach the clamp to a track:

1. Insert the square nut on the clamp into the T-slot of the dynamics track.
2. Insert a 0.5 inch rod into the clamp.
3. Adjust the track and clamp until the track is placed at the desired angle.

**TIP:** Place the clamp as close to the inclined end of the track as possible for stability.

4. Turn each thumbscrew to secure the clamp to the rod and track.

## Set up the pulley with a cart and track

The Super Pulley is designed to clamp onto the end of a dynamics track. The pulley can be adjusted so that a string attached to the upper or lower tie point of a cart is parallel with the track.

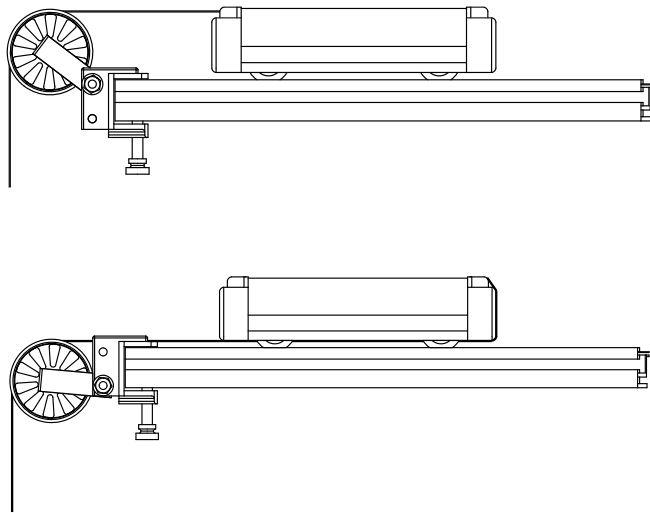

Figure 4. Super pulley setup with string attached to the upper and lower tie point on a cart.

1. Place the pulley at the end of the track. Gently turn the thumbscrew to secure the pulley.

**⚠ CAUTION:** Do not apply excessive force when tightening the thumbscrew to avoid damaging the screw.

2. Tie a string to the upper or lower tie point on the cart and run the string over the pulley. Attach a mass to the other end of the string.

**💡 TIP:** When the string is attached to the lower tie point, the string can be run under an end stop, another cart, or a Motion Sensor.

3. Adjust the height of the pulley to make the string parallel to the track.

## Attach a Spring to a Cart

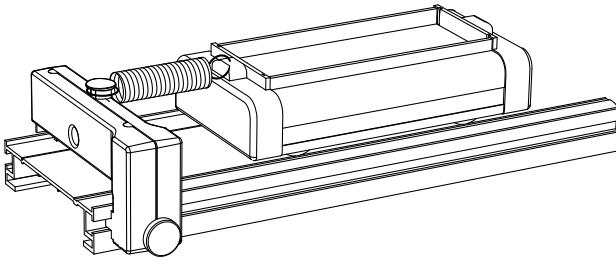

*Figure 5. A spring attached to a Dynamics Cart and End Stop on a Dynamics Track.*

The springs are designed for use with the PASCO Dynamics System by attaching a dynamics cart to an End Stop. To use the springs with a cart:

1. Attach an End Stop to a track.
2. Attach one end of the spring to the dynamics cart upper tie point.
3. Attach the other end of the spring to the End Stop spring attachment stud.



## Using the Angle Indicator

The Angle Indicator is used for measuring angles from 0 to 90° in two directions and can attach to lab equipment in a variety of ways.

### Attach to a Dynamics Track

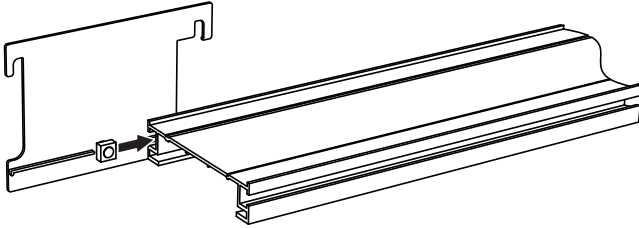

Figure 6. Inserting an Angle Indicator into the T-slot of a Dynamics Track.

1. Insert the square nut on the Angle Indicator into the T-slot of the track.
2. Move the Angle Indicator to the desired position on the track.

**TIP:** When a Motion Sensor is attached to the end of the track, place the Angle Indicator as close to the sensor as possible. This will help prevent the indicator from interfering with measurements made by the Motion Sensor.

3. Turn the thumbscrew to secure the Angle Indicator to the track.

### Attach to a Dynamics Cart

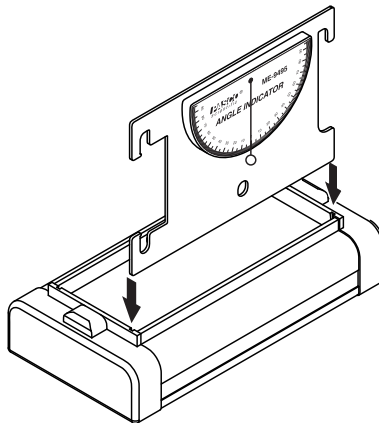
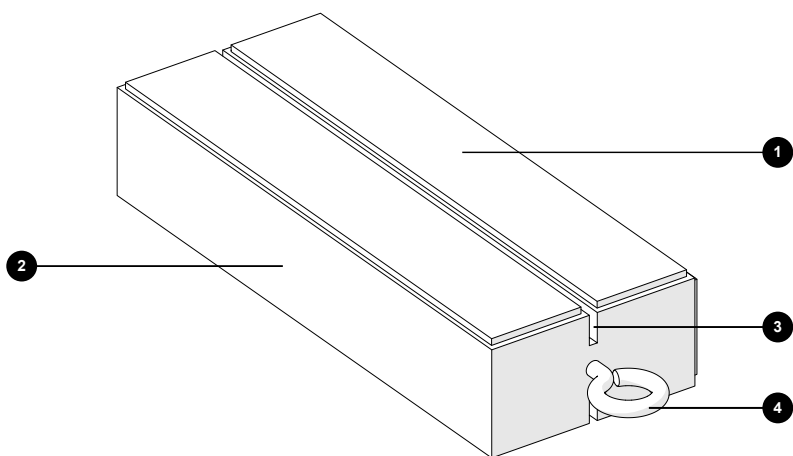

Figure 7. Inserting an Angle Indicator into the slot of a Dynamics Cart.

Attach the Angle Indicator to a Dynamics Cart by inserting the indicator into the slots on top of the cart.

## Friction Block Features

The Friction Block is constructed of wood covered with felt on two sides. Each side has a different surface area to measure the effect of surface area on frictional force. The block is designed to fit into the tray of a dynamics cart so that the cart can move on its wheels or turned upside down to move on the Friction Block without changing the mass.



### 1 Felt surface

Two sides of different surface area are covered with felt to compare the coefficient of friction to wood.

### 2 Wood surface

Two sides of different surface area are bare wood to compare the coefficient of friction to felt.

### 3 Slot

Use the slot to insert a Cart Picket Fence (ME-9804) or Angle Indicator (ME-9495A).

### 4 Eye Hook

Tie a string to the eye hook to pull the block.

## Using the Masses with a Cart

The Cart Masses are designed to be placed in the tray of any PASCO dynamics cart. One mass has approximately the same mass as a single plastic cart (including the Smart Cart) and half the mass of a metal cart. The cart tray can accommodate two masses. Add additional masses by stacking the bars. The built-in grooves on the bottom of the bars keep the masses in place.

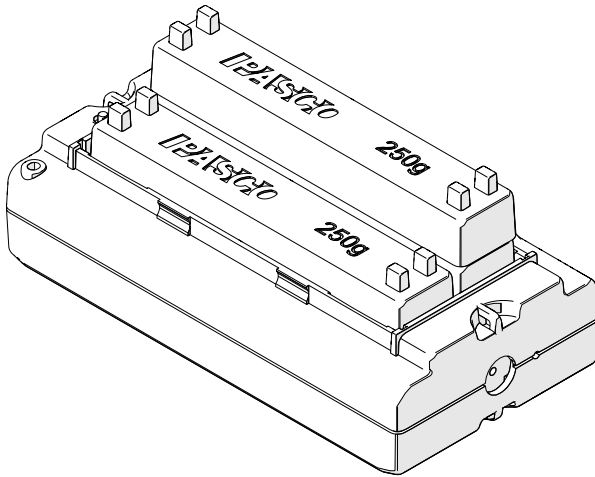

Figure 8. A Smart Cart holding stacked cart masses

## Experiments

Print-ready experiment worksheets for this product are available to download from the PASCO website. Go to [www.pasco.com/freelabs](http://www.pasco.com/freelabs) and enter **ME-5717A** to access all experiments related to this product.

# Appendix

## Technical Support

Contact PASCO Technical Support for assistance with this or any other PASCO product.

|         |   |
|---------|---|
| Address | PASCO scientific<br>10101 Foothills Blvd.<br>Roseville, CA 95747-7100 |
| Phone   | 1-800-772-8700 (USA)<br>1-916-462-8384 (International)                |
| Chat    | <a href="http://www.pasco.com">www.pasco.com</a>                      |
| email   | <a href="mailto:support@pasco.com">support@pasco.com</a>              |

## Warranty, Copyright, and Trademarks

### Limited Warranty

For a description of the product warranty, see the Warranty and Returns page at [www.pasco.com/legal](http://www.pasco.com/legal).

### Copyright

This document is copyrighted with all rights reserved. Permission is granted to non-profit educational institutions for reproduction of any part of this manual, providing the reproductions are used only in their laboratories and classrooms, and are not sold for profit. Reproduction under any other circumstances, without the written consent of PASCO scientific, is prohibited.

### Trademarks

PASCO and PASCO scientific are trademarks or registered trademarks of PASCO scientific, in the United States and/or in other countries. All other brands, products, or service names are or may be trademarks or service marks of, and are used to identify, products or services of, their respective owners. For more information visit [www.pasco.com/legal](http://www.pasco.com/legal).

## Product End of Life Disposal Instructions



This electronic product is subject to disposal and recycling regulations that vary by country and region. It is your responsibility to recycle your electronic equipment per your local environmental laws and regulations to ensure that it will be recycled in a manner that protects human health and the environment. To find out where you can drop off your waste equipment for recycling, please contact your local waste recycle or disposal service, or the place where you purchased the product.

The European Union WEEE (Waste Electronic and Electrical Equipment) symbol and on the product or its packaging indicates that this product must not be disposed of in a standard waste container.

## Battery Disposal Instructions

Batteries contain chemicals that, if released, may affect the environment and human health. Batteries should be collected separately for recycling and recycled at a local hazardous material disposal location adhering to your country and local government regulations. To find out where you can drop off your waste battery for recycling, please contact your local waste disposal service, or the product representative. The battery used in this product is marked with the International symbols to indicate the need for the separate collection and recycling of batteries.

## FCC Statement

This Class A digital device complies with part 15 of the FCC Rules. Operation is subject to the following two conditions: (1) This device may not cause harmful interference, and (2) this device must accept any interference received, including interference that may cause undesired operation.

## CE Statement

This device has been tested and found to comply with the essential requirements and other relevant provisions of the applicable EU Directives.